

DESCRIPTION:

The DPS92256 is a 32K X 8 Static Random Access Memory (SRAM) fabricated with a CMOS silicon gate process. The memory utilizes asynchronous circuitry and may be maintained in any state for an indefinite period of time. All pins are TTL compatible, and a single +5V power supply is required.

The DPS92256 is ideally suited for use in microprocessor systems and other applications where fast access time and ease of use are required. All devices offer the advantages of low power dissipation, low cost and high performance.

FEATURES:

- 32,768 Words by 8-Bits Organization
- Access Times: 85*, 100, 120, 150ns (max.)
- Low Power: 1.1mW (max.) Full Standby
- Fully Static Operation; No Clock or Refresh Required
- TTL Compatible Input and Output
- Common Data Input and Output
- Single +5V Power Supply, $\pm 10\%$ Tolerance
- Three State Output
- Standard 28-Pin DIP or 32-Pad LCC Packages

* Commercial only.

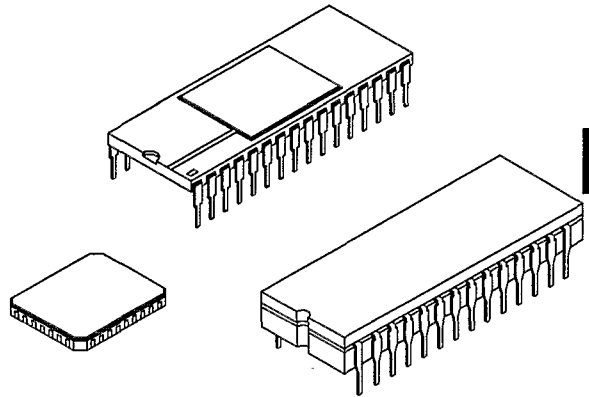

3

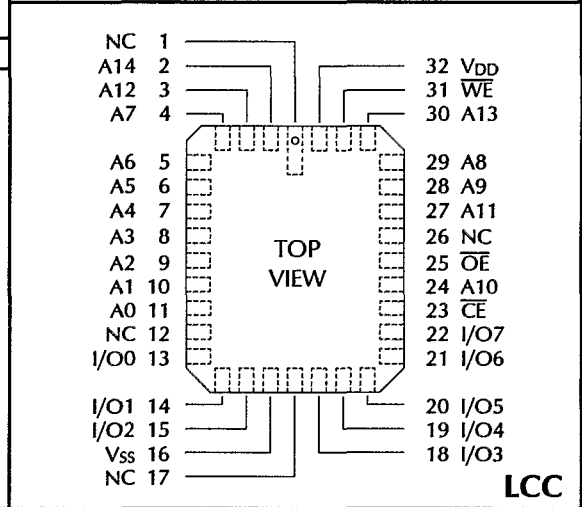
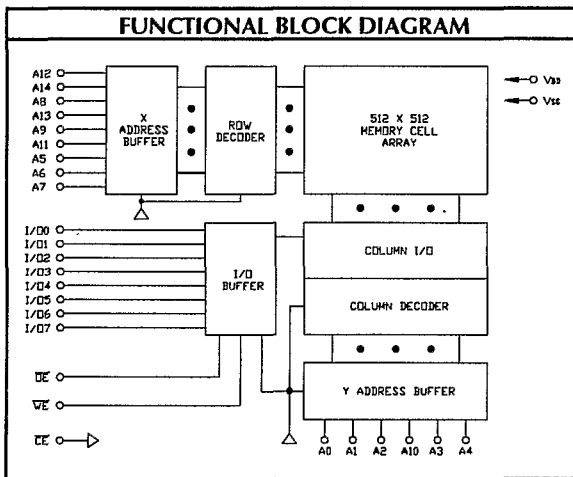
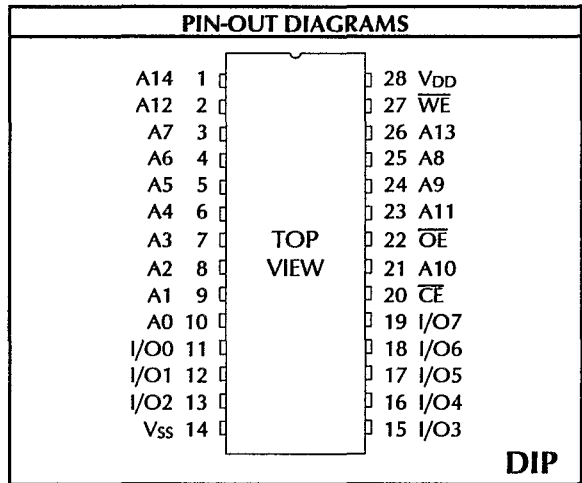

TRUTH TABLE					
Mode	\overline{CE}	\overline{OE}	\overline{WE}	I/O Pin	Supply Current
Not Selected	H	X	X	HIGH-Z	Standby
DOUT Disable	L	H	H	HIGH-Z	Active
Read	L	L	H	DOUT	Active
Write	L	X	L	DIN	Active

L = LOW H = HIGH X = Don't Care

RECOMMENDED OPERATING RANGE ¹					
Symbol	Characteristic	Min.	Typ.	Max.	Unit
V _{DD}	Supply Voltage	4.5	5.0	5.5	V
V _{IH}	Input HIGH Voltage	2.2		V _{DD} +0.3	V
V _{IL}	Input LOW Voltage	-0.5 ²		0.8	V

ABSOLUTE MAXIMUM RATINGS ³			
Symbol	Parameter	Value	Unit
T _{STC}	Storage Temperature	-65 to +150	°C
T _{BIAS}	Temperature Under Bias	-55 to +125	°C
V _{DD}	Supply Voltage ¹	-0.5 to +7.0	V
V _{I/O}	Input/Output Voltage ¹	-0.5 to V _{DD} +0.5	V

PIN NAMES	
A0-A14	Address Inputs
I/O0 - I/O7	Data In/Out
\overline{CE}	Chip Enable
\overline{WE}	Write Enable
\overline{OE}	Output Enable
V _{DD}	Power (+5V)
V _{SS}	Ground

CAPACITANCE ⁴ : T _A = 25°C, F = 1.0MHz				
Symbol	Parameter	Max.	Unit	Condition
C _{CE}	Chip Enable	7	pF	V _{IN} =0V
C _{ADR}	Address Input	7		
C _{WE}	Write Enable	7		
C _{OE}	Output Enable	7		
C _{I/O}	Data Input/Output	10		

DC OPERATING CHARACTERISTICS: Over operating ranges									
Symbol	Characteristics	Test Conditions	C		I		M/B		Unit
			Min.	Max.	Min.	Max.	Min.	Max.	
I _{IN}	Input Leakage Current	V _{IN} = 0V to V _{DD}	-2	2	-2	2	-2	2	µA
I _{OUT}	Output Leakage Current	V _{I/O} = 0V to V _{DD} , \overline{CE} or \overline{OE} = V _{IH} , or \overline{WE} = V _{IL}	-2	2	-2	2	-2	2	µA
I _{CC1}	Active Supply Current	\overline{CE} = V _{IL} , V _{IN} = V _{IH} or V _{IL} , I _{OUT} = 0mA		45		45		45	mA
I _{CC2}	Operating Supply Current	Cycle = min., Duty = 100% I _{OUT} = 0mA		60		65		70	mA
I _{SB1}	Full Standby Supply Current	\overline{CE} ≥ V _{DD} -0.2V		100		200		300	µA
I _{SB2}	Standby Supply	\overline{CE} = V _{IH}		2		2		2	mA
V _{OL}	Output Low Voltage	I _{OUT} = 2.1mA		0.4		0.4		0.4	V
V _{OH}	Output High Voltage	I _{OUT} = -1.0mA	2.4		2.4		2.4		V

DATA RETENTION DC CHARACTERISTICS									
Symbol	Characteristics	Test Conditions	C		I		M/B		Unit
			Min.	Max.	Min.	Max.	Min.	Max.	
I _{CCDR3}	Data Retention Supply Current	V _{DR} = 3V, \overline{CE} ≥ V _{DR} -0.2V		40		50		240	µA
I _{CCDR2}	Data Retention Supply Current	V _{DR} = 2V, \overline{CE} ≥ V _{DR} -0.2V		30		40		200	µA

DATA RETENTION CHARACTERISTICS						
Symbol	Parameter	Test Condition	Min.	Typ.	Max.	Unit
V _{DR}	Data Retention Voltage	\overline{CE} ≥ V _{DD} -0.2V	2.0	5.0	5.5	V
t _{CDR}	Chip Disable to Data Retention Time		0			ns
t _r	Recovery Time	t _{rc} = Read Cycle Timing	t _{rc}			ns



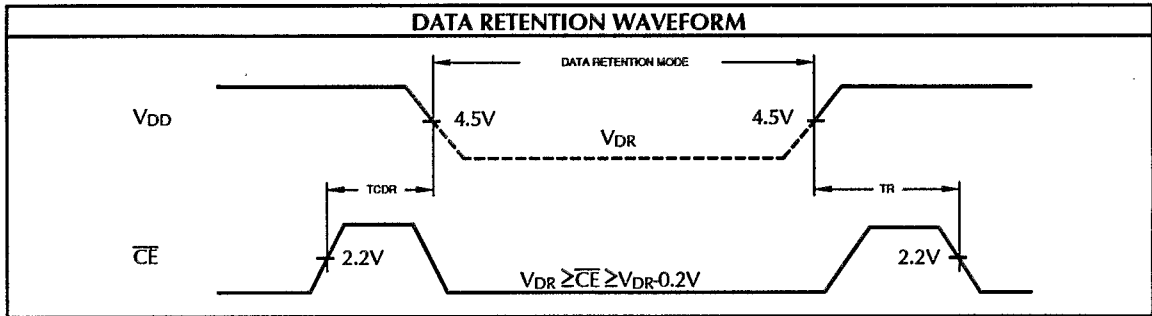

AC TEST CONDITIONS	
Input Pulse Levels	0V to 3.0V
Input Pulse Rise and Fall Times	5ns*
Input and Output Timing Reference Levels	1.5V

* Transition between 0.8V and 2.2V.

OUTPUT LOAD		
Load	C _L	Parameters Measured
1	100pF	except tCLZ, tCHZ, tOHZ, tOLZ, tWLZ and tWHZ
2	5pF	tCLZ, tCHZ, tOHZ, tOLZ, tWLZ and tWHZ

Figure 1. Output Load

** Including Probe and Jig Capacitance.

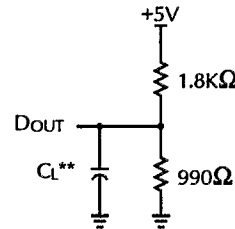

AC OPERATING CONDITIONS AND CHARACTERISTICS - READ CYCLE: Over operating ranges											
No.	Symbol	Parameter	-85†		-100		-120		-150		Unit
			Min.	Max.	Min.	Max.	Min.	Max.	Min.	Max.	
1	t _{RC}	Read Cycle Time	85		100		120		150		ns
2	t _{AA}	Address Access Time		85		100		120		150	ns
3	t _{CO}	Chip Enable to Output Valid		85		100		120		150	ns
4	t _{OV}	Output Enable to Output Valid		60		60		60		70	ns
5	t _{OH}	Output Hold from Address Change			10		10		10		ns
6	t _{CLZ}	Chip Enable to Output in LOW-Z ^{4, 5}			10		10		10		ns
7	t _{OLZ}	Output Enable to Output in LOW-Z ^{4, 5}			5		5		5		ns
8	t _{CHZ}	Chip Enable to Output in HIGH-Z ^{4, 5}			35		40		50		ns
9	t _{OHZ}	Output Enable to Output in HIGH-Z ^{4, 5}			35		40		50		ns

AC OPERATING CONDITIONS AND CHARACTERISTICS - WRITE CYCLE ^{6,7} : Over operating ranges											
No.	Symbol	Parameter	-85†		-100		-120		-150		Unit
			Min.	Max.	Min.	Max.	Min.	Max.	Min.	Max.	
10	t _{WC}	Write Cycle Time	85		100		120		150		ns
11	t _{AW}	Address Valid to End of Write	75		90		100		120		ns
12	t _{CW}	Chip Enable to End of Write	75		90		100		120		ns
13	t _{DW}	Data Valid to End of Write	35		40		50		60		ns
14	t _{DH}	Data Hold Time	0		0		0		0		ns
15	t _{WP}	Write Pulse Width	65		75		90		110		ns
16	t _{AS}	Address Set-up Time ^{***}	0		0		0		0		ns
17	t _{AH}	Address Hold Time	0		0		0		0		ns
18	t _{WHZ}	Write Enable to Output in HIGH-Z ^{4, 5}		30		35		40		50	ns
19	t _{WLZ}	Write Enable to Output in LOW-Z ^{4, 5}		5		5		5		5	ns

*** Valid for both Read and Write Cycles.

† Commercial only.

READ CYCLE 1: Address Controlled. \overline{WE} is HIGH. \overline{CE} and \overline{OE} are LOW.

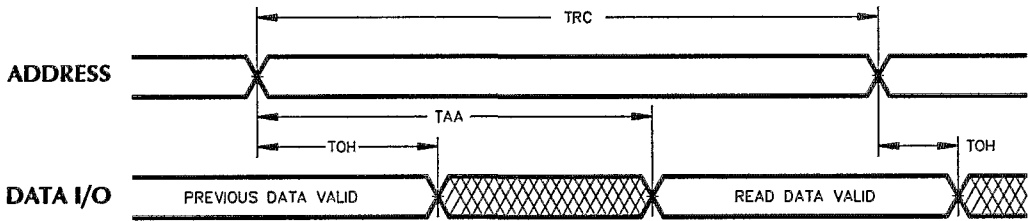

READ CYCLE 2: \overline{CE} Controlled. \overline{WE} is HIGH.

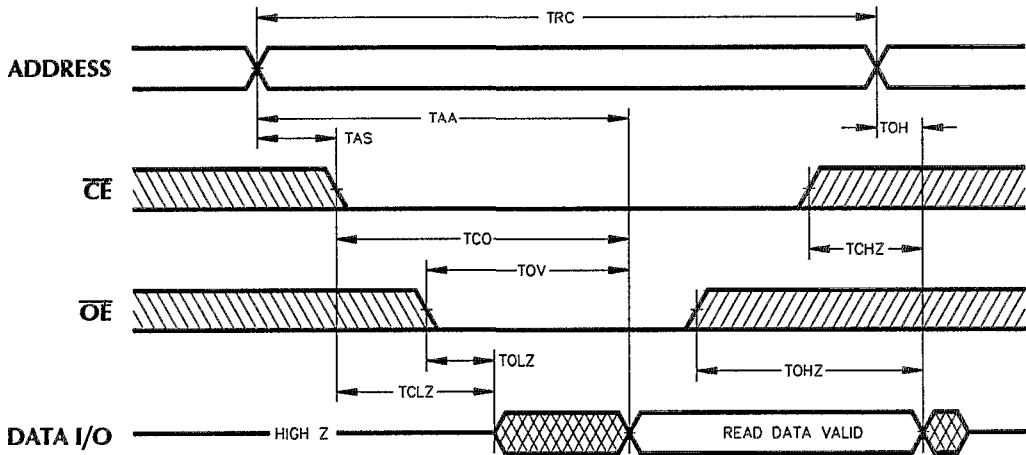

WRITE CYCLE 1: \overline{WE} Controlled. \overline{OE} is LOW.

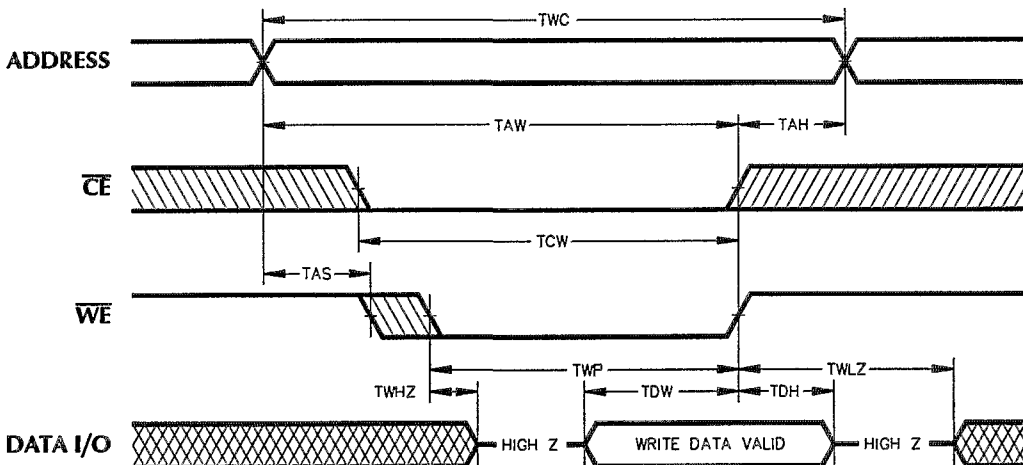

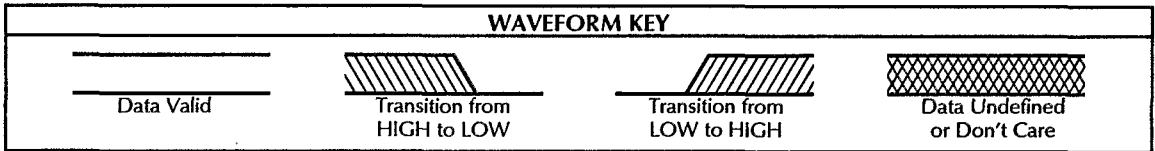
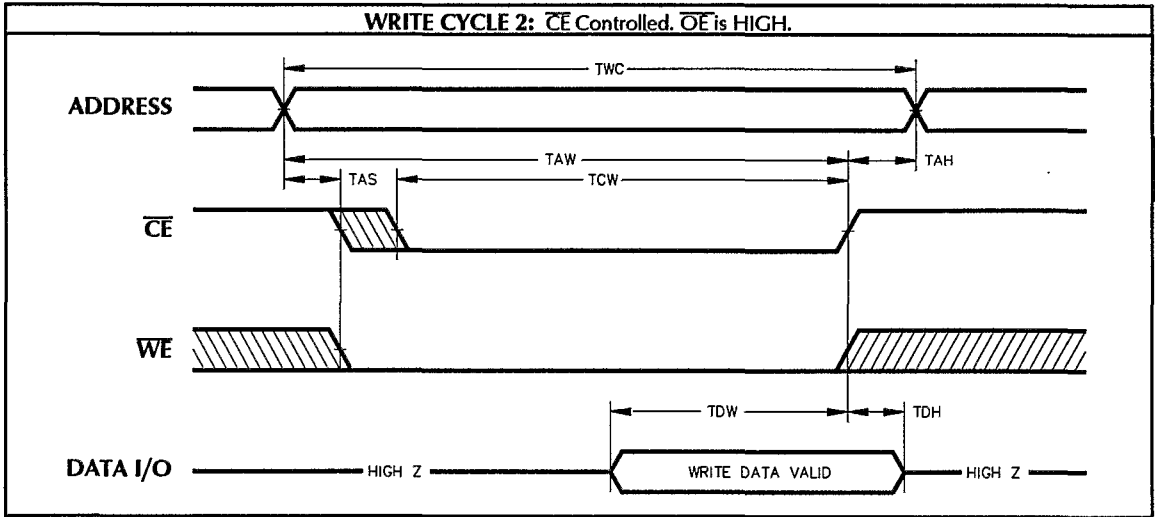

NOTES:

1. All voltages are with respect to V_{SS} .
2. -2.0V min. for pulse width less than 20ns (V_{IL} min. = -0.5V at DC level).
3. Stresses greater than those under **ABSOLUTE MAXIMUM RATINGS** may cause permanent damage to the device. This is a stress rating only and functional operation of the device at these or any other conditions above those indicated in the operational sections of this specification is not implied. Exposure to absolute maximum rating conditions for extended periods may affect reliability.
4. This parameter is guaranteed and not 100% tested.
5. Transition is measured at the point of ± 500 mV from steady state voltage.
6. When \overline{OE} and \overline{CE} are LOW and \overline{WE} is HIGH, I/O pins are in the output state; and, input signals of opposite phase to the outputs must not be applied.
7. The outputs are in a high impedance state when \overline{WE} is LOW.

ORDERING INFORMATION

DP	S92256	X	-XXX	X		
PREFIX	DEVICE TYPE	PACKAGE	SPEED	GRADE		
C					85	COMMERCIAL 0°C to +70°C
I					100	INDUSTRIAL -40°C to +85°C
M					120	MILITARY -55°C to +125°C
B					150	MIL-PROCESSED -55°C to +125°C
						(COMMERCIAL ONLY)
					G	32 PAD LCC
					N	28 LEAD SIDE BRAZED DIP
					NONE	28 LEAD CERDIP
						32K X 8 CMOS SRAM



MECHANICAL DIAGRAMS

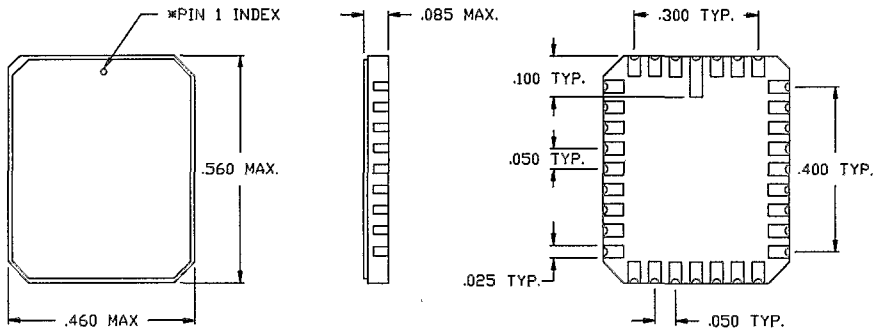

LCC

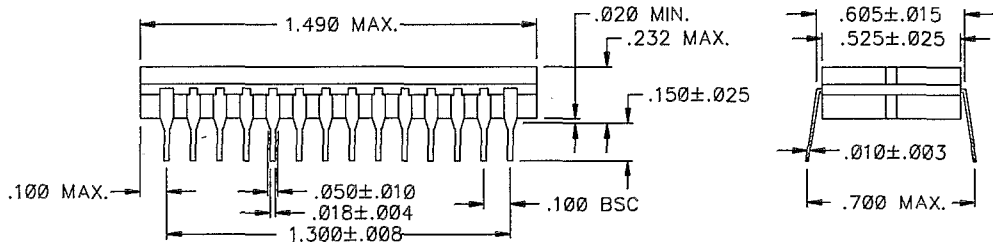

CERDIP

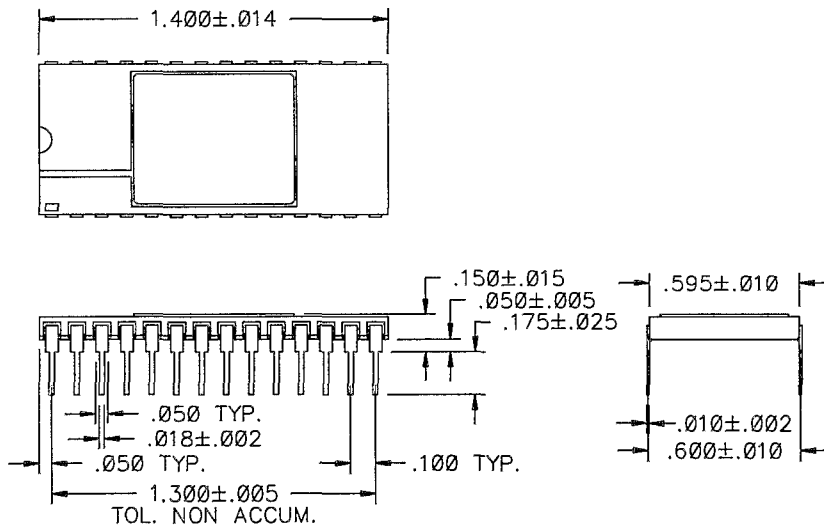

SIDE BRAZED DIP

Dense-Pac Microsystems, Inc.

7321 Lincoln Way • Garden Grove, California 92641-1428
 (714) 898-0007 • (800) 642-4477 (Outside CA) • FAX: (714) 897-1772

