

REVISION BY

DO NOT SCALE FROM THIS PRINT

| TABLE 1 | | |
|------------|---------------|-------------------------------------|
| LEAD STYLE | "A" | CONTACT |
| -01 | 0.090 [2.29] | C-79-01-X |
| -01-S-RA | N/A | C-79-53-X |
| -01-D-RA | N/A | C-79-53-X C-79-12-X |
| -01-T-RA | N/A | C-79-53-X C-79-12-X C-79-12-X |
| -02 | 0.600 [15.24] | C-79-02-X |
| -03 | 0.208 [5.28] | C-79-53-X |

SQT-1XX-XX-XXX-X-XXX-XXX

No OF POSITIONS
-02 THRU -50 (PER ROW)
-01 (SEE NOTE 3)
LEAD STYLE (SEE TABLE 1)
PLATING SPECIFICATION
-F: 3µ" SELECTIVE GOLD IN CONTACT AREA, MATTE TIN ON TAIL.
-L: 10µ" SELECTIVE GOLD IN CONTACT AREA, MATTE TIN ON TAIL.
-G: 20µ" SELECTIVE GOLD IN CONTACT AREA, 3µ" SELECTIVE GOLD ON TAIL.
-S: 30µ" SELECTIVE GOLD IN CONTACT AREA, MATTE TIN ON TAIL.
-H: 50µ" SELECTIVE GOLD IN CONTACT AREA, 3µ" SELECTIVE GOLD ON TAIL.
-FM: 3µ" SELECTIVE GOLD IN CONTACT AREA, MATTE TIN ON TAIL.
-LM: 10µ" SELECTIVE GOLD IN CONTACT AREA, MATTE TIN ON TAIL.
-SM: 30µ" SELECTIVE GOLD IN CONTACT AREA, MATTE TIN ON TAIL.
-STL: 30µ" SELECTIVE GOLD IN CONTACT AREA, SnPb ON TAIL.

POLARIZATION OPTION
-XXX: INDICATES POSITION (SEE NOTE 10)
OPTION
-RA: RIGHT ANGLE
(-01 LEAD STYLE, ROWS -S, -D, -T ONLY)
(NOT AVAILABLE ON -Q, -5 & -6 ROWS)
(SINGLE, DOUBLE, TRIPLE ROW: SEE FIG 2, SHT 2)
*SD1: SOLDER DONUT (SEE FIG 3, SHT 2)
(AVAILABLE ON -S, -D, -T ONLY)
**MW: METAL WASHER (SHT 2, SEE FIG 4)
(AVAILABLE ON LEAD STYLES -01 & -03 ONLY)
(5 POS MIN, 30 POS MAX, .300 MAX TAIL)
ROW SPECIFICATION
-S: SINGLE (USE SQT-61-S)
-D: DOUBLE (USE SQT-62-D)
-T: TRIPLE (USE SQT-62-T)
-Q: QUAD (USE SQT-62-Q)
-5: FIVE ROW (USE SQT-62-5)
-6: SIX ROW (USE SQT-62-6)

* = NOT RELEASED FOR PRODUCTION
** = MW OPTION, DO NOT DESIGN IN, SAMTEC WILL ONLY SUPPORT EXISTING BUSINESS 02/06/2002

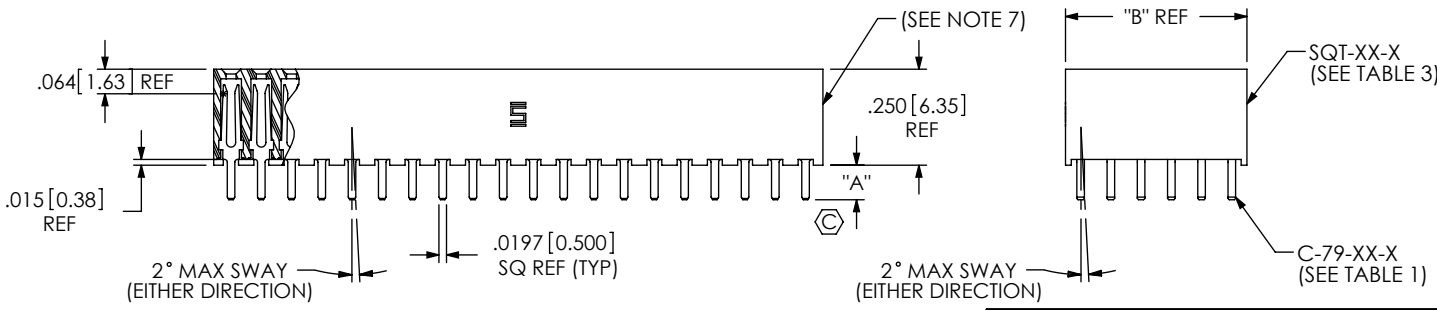
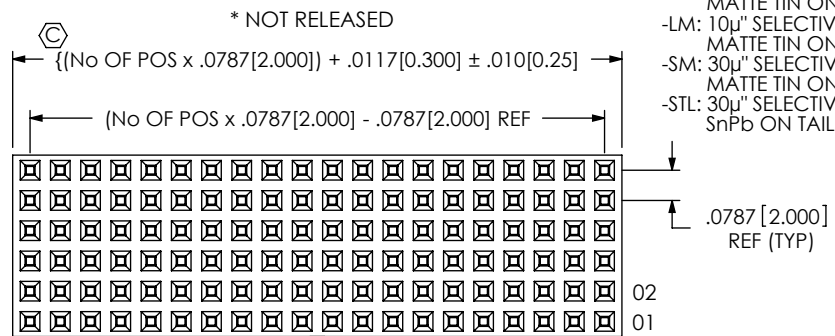

| TABLE 3 | | |
|----------|----------|-----------------|
| ROW SPEC | BODY | "B" |
| -S | SQT-61-S | 0.0787 [2.000] |
| -D | SQT-62-D | 0.1575 [4.000] |
| -T | SQT-62-T | 0.2362 [6.000] |
| -Q | SQT-62-Q | 0.3150 [8.000] |
| -5 | SQT-62-5 | 0.3937 [10.000] |
| -6 | SQT-62-6 | 0.4724 [12.000] |

FIG 1
SQT-120-0T-XX-6 SHOWN

- NOTES:
- ⊕ REPRESENTS A CRITICAL DIMENSION.
 - MINIMUM CONTACT RETENTION: .5 LB
 - 01 POSITION OFFERED FOR SINGLE ROW & ONLY FOR -S, -D, & -T ROWS RIGHT ANGLE ONLY.
 - 01, -02, & -03 & ONLY FOR -S, -D, & -T ROWS POSITIONS TO BE LAYER PACKAGED.
 - STOCK 62 POSITION FOR -D AND 61 POSITION FOR -S, -01 LEAD STYLE ONLY. TO BE CUT TO POSITION FOR CUSTOMER.
 - MAXIMUM BURR: .005[0.13]
 - ENDWALL AFTER CUTTING: .033[0.84]±.004[0.10], VOIDS MAY BE PRESENT. CONTACTS MUST NOT BE VISIBLE THROUGH THE ENDWALL.
 - MAXIMUM CUT FLASH: .020[0.50]
 - MAXIMUM HEIGHT VARIATION: .005[0.13]
 - INSERT PK-07-N INTO SPECIFIED POSITION AND BREAK OFF TAB.



| | | |
|--|--|--|
| UNLESS OTHERWISE SPECIFIED, DIMENSIONS ARE IN INCHES. TOLERANCES ARE: DECIMALS ANGLES .XX: ±.01 [.3] 2° .XXX: ±.005 [.13] .XXXX: ±.0020 [.051] | PROPRIETARY NOTE THIS DOCUMENT CONTAINS INFORMATION CONFIDENTIAL AND PROPRIETARY TO SAMTEC, INC. AND SHALL NOT BE REPRODUCED OR TRANSFERRED TO OTHER DOCUMENTS OR DISCLOSED TO OTHERS OR USED FOR ANY PURPOSE OTHER THAN THAT WHICH IT WAS OBTAINED WITHOUT THE EXPRESSED WRITTEN CONSENT OF SAMTEC, INC. | 520 PARK EAST BLVD., NEW ALBANY, IN 47150 PHONE: 812-944-6733 FAX: 812-948-5047 e-Mail: info@SAMTEC.com code 55322 |
| | | |

REVISION BY

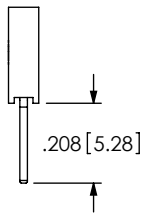

IN PROCESS 1
(LEAD STYLE -01-S,D,T-RA)

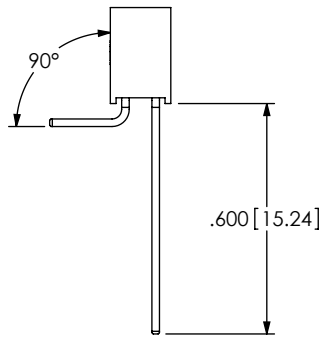

IN PROCESS 2
(LEAD STYLE -01-D,T-RA)

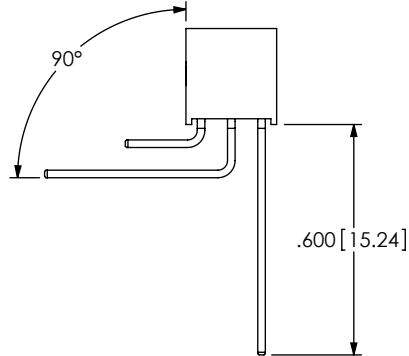

IN PROCESS 3
(LEAD STYLE -01-T-RA)

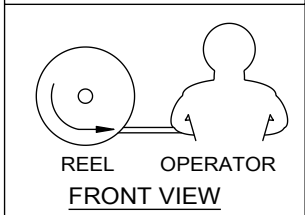
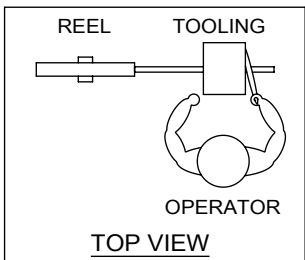

WASHER REEL ASSEMBLY
ORIENTATION VIEW

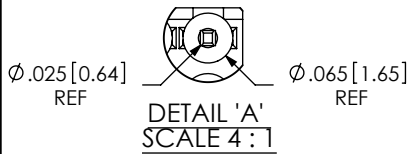
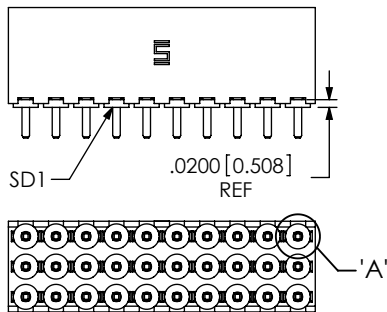

FIG 3
*SD1: SOLDER DONUT
(ONE PER POSITION)
(ROW STYLE -S,-D,-T & -Q ONLY)
*NOT ENGINEERING APPROVED

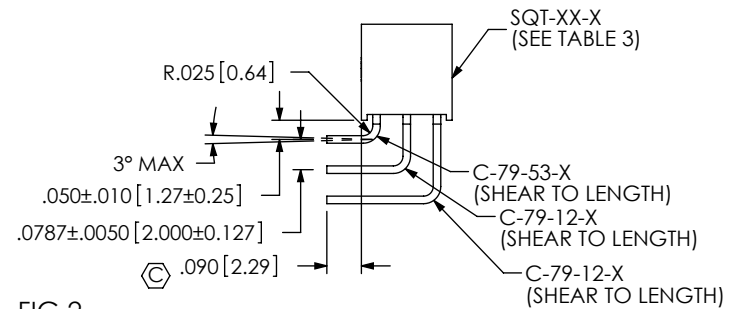
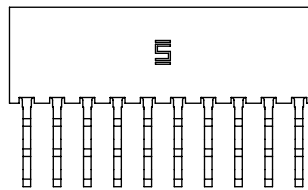
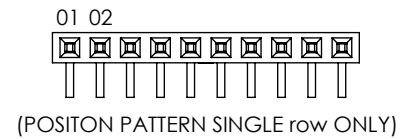
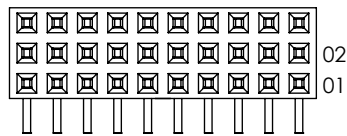

FIG 2
-RA: RIGHT ANGLE
(LEAD STYLE -01-D,T)

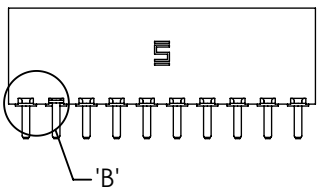
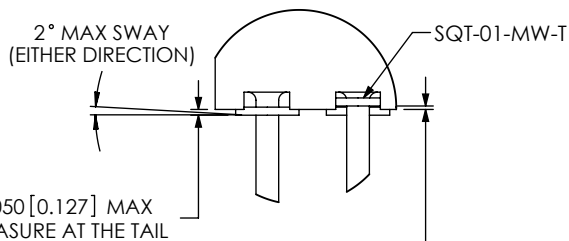

FIG 4
**-MW: METAL WASHER
(ONE PER POSITION)
(AVAILABLE ON LEADSTYLES -01 & -03 ONLY
(5 POS MIN, 30 POS MAX)
**-MW OPION, DO NOT DESIGN IN. SAMTEC WILL
ONLY SUPPORT EXISTING BUSINESS 2/06/02.



DETAIL 'B'
SCALE 6:1

PROPRIETARY NOTE

THIS DOCUMENT CONTAINS INFORMATION
CONFIDENTIAL AND PROPRIETARY TO
SAMTEC, INC. AND SHALL NOT BE REPRODUCED
OR TRANSFERRED TO OTHER DOCUMENTS OR
DISCLOSED TO OTHERS OR USED FOR ANY
PURPOSE OTHER THAN THAT WHICH IT WAS
OBTAINED WITHOUT THE EXPRESSED WRITTEN
CONSENT OF SAMTEC, INC.

DO NOT SCALE DRAWING

SHEET SCALE: 2:1

samtec

520 PARK EAST BLVD, NEW ALBANY, IN 47150
PHONE: 812-944-6733 FAX: 812-948-5047
e-Mail: info@SAMTEC.com code 55322

DESCRIPTION:
2MM SOCKET STRIP ASSEMBLY

DWG. NO.
SQT-1XX-XX-XXX-X-XXX-XXX

BY: BRATCHER 07/24/1995 SHEET 2 OF 3

REVISION BY

PACKAGING VIEWS

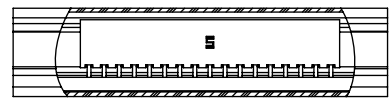

SQT-1XX-01-XX-D
(SEE TABLE 2)

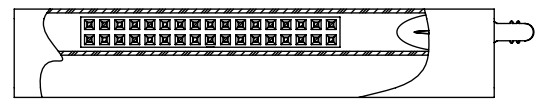

SQT-1XX-02-XX-D
(LOCATE PLUG AS SHOWN)
(SEE TABLE 2)

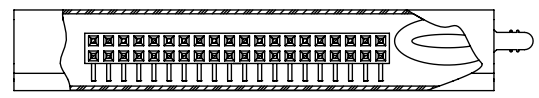

SQT-1XX-01-XX-D-RA SHOWN
(LOCATE PLUG AS SHOWN)
(SEE TABLE 2)

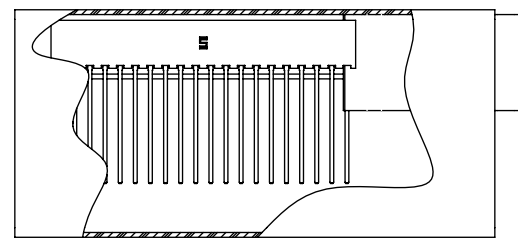
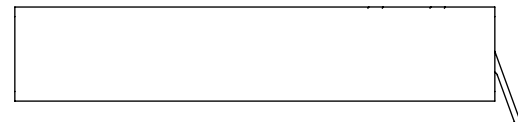
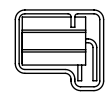

SQT-1XX-05-XX-X
(LOCATE PLUG AS SHOWN)
(SEE TABLE 2)

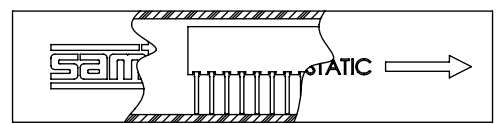
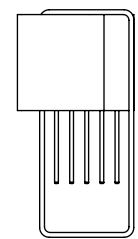

SQT-1XX-03-XX-6 SHOWN
(SEE TABLE 2)

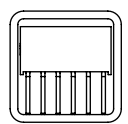

| TABLE 2 | | | |
|---------------------|--------------|-----------------|-----------|
| ROW SPEC. | No. OF POS | PKG TUBE | TUBE PLUG |
| -03-S | 04-50 | PT-1-24-06-17 | TP-24 |
| -02-S | 04-50 | PT-1-24-10-03 | TP-03 |
| -01-S-RA | 04-50 | PT-1-24-01-43 | TP-24 |
| -01-D | 04-50 | PT-1-24-02-17 | TP-09 |
| -02-D | 04-50 | PT-1-24-01-34 | TP-07 |
| -03-D | 04-50 | PT-1-24-01-22 | TP-03 |
| -01-D-RA | 04-50 | PT-1-24-01-45 | TP-03 |
| -01-T | 04-50 | PT-1-24-05-09 | TP-07 |
| -02-T | 04-50 | PT-1-24-01-102 | TP-07 |
| -03-T | 04-50 | PT-1-24-08-15 | TP-07 |
| -01-Q | 04-50 | PT-1-24-15-29 | TP-07 |
| -02-Q | 04-50 | PT-1-24-02-51 | TP-13 |
| -03-Q | 04-50 | PT-1-24-16-29 | TP-07 |
| -01-T-RA | 04-50 | PT-1-24-06-40 | TP-07 |
| -01-S | 04-50 | PT-1-24-05-15 | TP-24 |
| -03-5 | 15-50 | PT-1-24-01-08 | TP-13 |
| -02-5 | 15-50 | PT-1-24-01-56 | TP-31 |
| -01-6 | ALL | PT-1-24-01-52 | TP-07 |
| -02-6 | ALL | PT-1-25-03-28 | TP-13 |
| -03-6 | ALL | PT-1-24-01-08 | TP-13 |
| -01-5 | 15-50 | PT-1-24-09F-109 | TP-07 |
| -01-5, -02-5, -03-5 | -02 THRU -14 | LAYER PACKAGING | |
| -S, -D, -T, -Q | -02 & -03 | LAYER PACKAGING | |

PROPRIETARY NOTE
 THIS DOCUMENT CONTAINS INFORMATION CONFIDENTIAL AND PROPRIETARY TO SAMTEC, INC. AND SHALL NOT BE REPRODUCED OR TRANSFERRED TO OTHER DOCUMENTS OR DISCLOSED TO OTHERS OR USED FOR ANY PURPOSE OTHER THAN THAT WHICH IT WAS OBTAINED WITHOUT THE EXPRESSED WRITTEN CONSENT OF SAMTEC, INC.

DO NOT SCALE DRAWING

SHEET SCALE: 1:1

samtec
 520 PARK EAST BLVD. NEW ALBANY, IN 47150
 PHONE: 812-944-6733 FAX: 812-948-5047
 e-Mail info@SAMTEC.com code 55322

DESCRIPTION:
2MM SOCKET STRIP ASSEMBLY

DWG. NO.
SQT-1XX-XX-XXX-X-XXX-XXX

BY: BRATCHER 07/24/1995 SHEET 3 OF 3