

General Description

The AOZ8131 is an ultra low capacitance one-line bi-directional transient voltage suppressor diode designed to protect high speed data lines and voltage sensitive electronics from high transient conditions and ESD.

This device incorporates one TVS diode in an ultra-small DFN 1006 package. It may be used to meet the ESD immunity requirements of IEC 61000-4-2, Level 4 ($\pm 15\text{kV}$ air, $\pm 8\text{kV}$ contact discharge).

The AOZ8131 comes in an RoHS compliant DFN 1006 package and is rated over a -40°C to $+85^{\circ}\text{C}$ ambient temperature range.

The ultra-small $1.0 \times 0.6 \times 0.5\text{mm}$ DFN package makes it ideal for applications where PCB space is a premium. The small size and high ESD protection makes it ideal for protecting voltage sensitive electronics from high transient conditions and ESD.

Features

- ESD protection for high-speed data lines:
 - Exceeds:
 - IEC 61000-4-2 (ESD) $\pm 24\text{kV}$ (air), $\pm 24\text{kV}$ (contact)
 - IEC 61000-4-4 (EFT) $\pm 40\text{A}$ (5/50nS)
 - IEC 61000-4-5 (Lightning) $\pm 4\text{A}$
 - Human Body Model (HBM) $\pm 30\text{kV}$
- Small package saves board space
- Ultra low capacitance: 1.25pF
- Low clamping voltage
- Low operating voltage: 5.0V
- Pb-free device

Applications

- Portable handheld devices
- Keypads, data lines, buttons
- Notebook computers
- Digital Cameras
- Portable GPS
- MP3 players



Typical Application

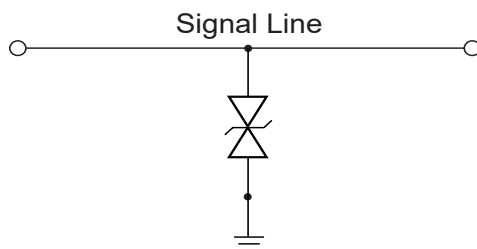

Bidirection Protection of Single Line

Pin Configuration

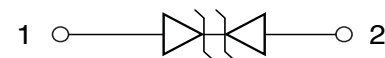

Ordering Information

Part Number	Ambient Temperature Range	Package	Environmental
AOZ8131DI-05L	-40°C to +85°C	DFN 1006	RoHS Compliant Green Product



AOS Green Products use reduced levels of Halogens, and are also RoHS compliant.

Please visit www.aosmd.com/media/AOSGreenPolicy.pdf for additional information.

Absolute Maximum Ratings

Exceeding the Absolute Maximum ratings may damage the device.

Parameter	Rating
Peak Pulse Current (I_{PP}), $t_P = 8/20\mu s$	4A
Storage Temperature (T_S)	-65°C to +150°C
ESD Rating per IEC61000-4-2, Contact ⁽¹⁾	±24kV
ESD Rating per IEC61000-4-2, Air ⁽¹⁾	±24kV
ESD Rating per Human Body Model ⁽²⁾	±30kV

Notes:

- IEC 61000-4-2 discharge with $C_{Discharge} = 150pF$, $R_{Discharge} = 330\Omega$.
- Human Body Discharge per MIL-STD-883, Method 3015 $C_{Discharge} = 100pF$, $R_{Discharge} = 1.5k\Omega$.

Maximum Operating Ratings

Parameter	Rating
Junction Temperature (T_J)	-40°C to +125°C

Electrical Characteristics

$T_A = 25^\circ C$ unless otherwise specified.

Symbol	Parameter	Symbol	Parameter
I_{PP}	Maximum Reverse Peak Pulse Current	I_T	Test Current
V_{CL}	Clamping Voltage @ I_{PP} (IEC61000-4-5 8/20 μs pulse)	P_{pk}	Peak Power Dissipation (IEC61000-4-5 8/20 μs pulse)
V_{RWM}	Working Peak Reverse Voltage	C_J	Max. Capacitance @ $V_R = 0$ and $f = 1MHz$
I_R	Maximum Reverse Leakage Current		
V_{BR}	Breakdown Voltage		

Electrical Characteristics

$T_A = 25^\circ C$ unless otherwise noted.

Device	Device Marking	V_{RWM} (V) Max.	V_{BR} (V) Min. $I_T = 1mA$	I_R (μA) Max.	V_{CL} Max.		Ppk (W)	C_J (pF)	
					$I_{PP} = 2A$	$I_{PP} = 4A$		Typ.	Max.
AOZ8131DI-05L	B	5.0	6.0	0.1	14.50	18.50	75	1.25	2.0

Typical Performance Characteristics

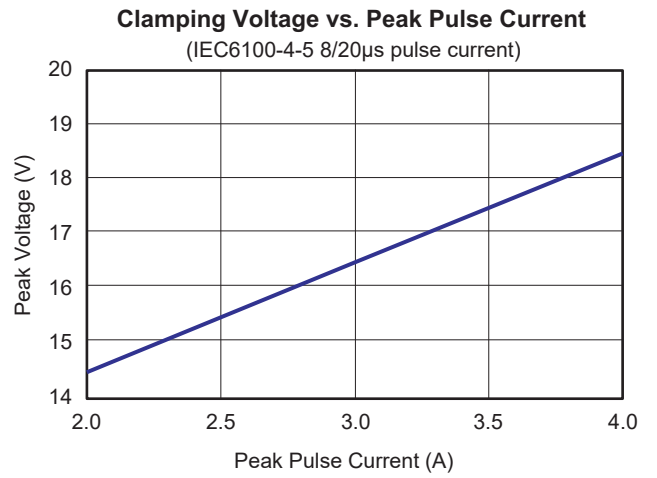
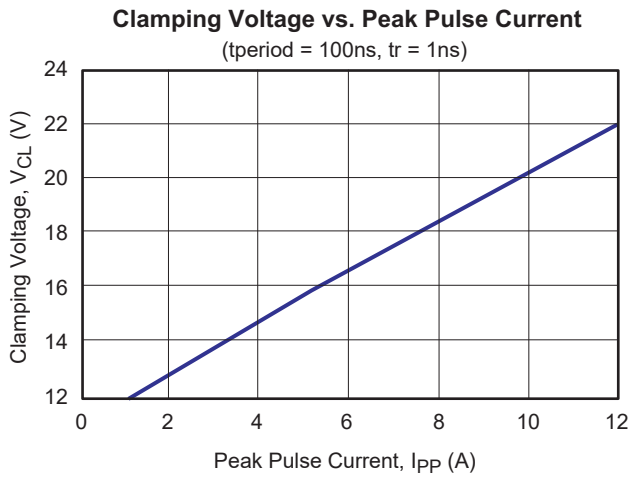

Package Dimensions, DFN 1.0 x 0.6

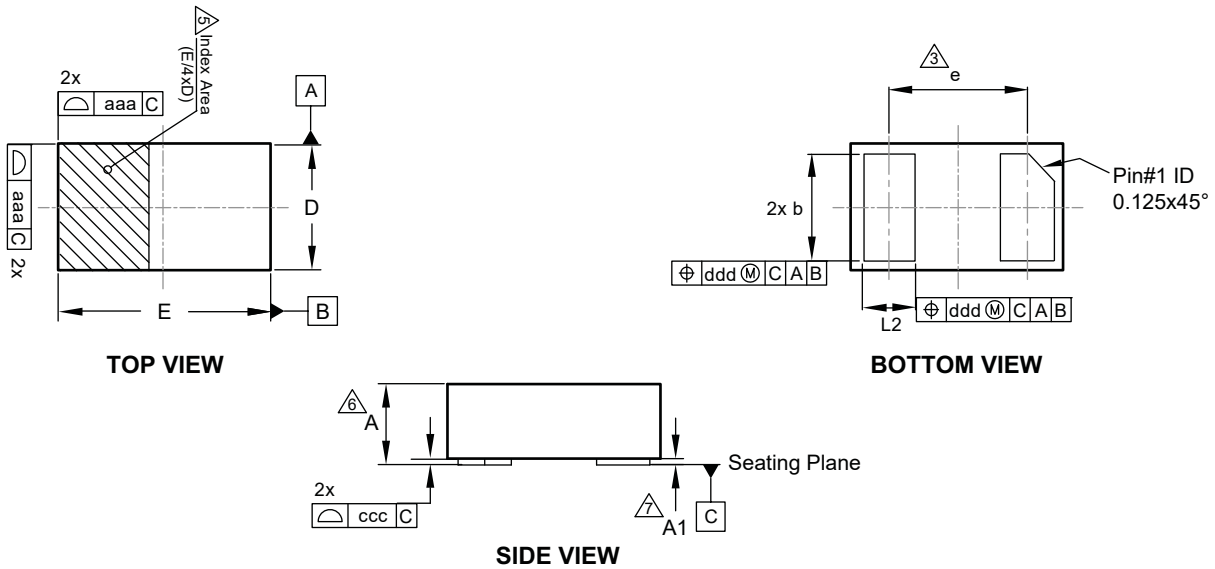

RECOMMENDED LAND PATTERN

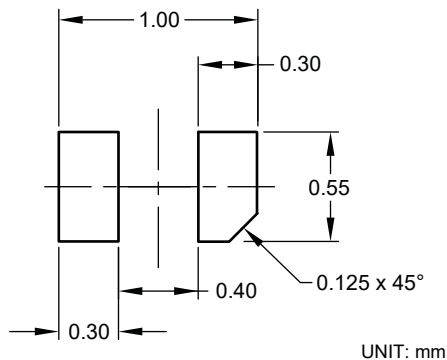

Dimensions in millimeters

Symbols	Min.	Nom.	Max.
A	0.47	0.51	0.55
A1	0.00	0.02	0.05
b	0.45	0.50	0.55
D	0.60 BSC		
E	1.00 BSC		
e	0.65 BSC		
L	0.20	0.25	0.30
aaa	0.05		
ccc	0.03		
ddd	0.10		

Dimensions in inches

Symbols	Min.	Nom.	Max.
A	0.019	0.020	0.022
A1	0.000	0.001	0.002
b	0.018	0.020	0.022
D	0.024		
E	0.039		
e	0.026		
L	0.008	0.010	0.012
aaa	0.002		
ccc	0.001		
ddd	0.004		

Notes:

1. Dimensions and tolerancing conform to ASME Y14.5-2009.
2. All dimensions are in millimeters.
3. "e" represents the terminal grid pitch.
4. N is the total number of terminals.
5. A visual index feature must be located within the hatched area. Typical index feature (chamfer) must be located on the edge of the Pin#1 feature.
6. This dimension includes stand-off height "A1" and packaged body thickness, but does not include attached feature e.g. external heatsink or chip capacitors, an internal heatslug is not considered as attached feature.
7. Dimension "A1" is primarily terminal plating, and does not include small metal protrusions.

Tape and Reel Dimensions, DFN 1.0 x 0.6

Carrier Tape

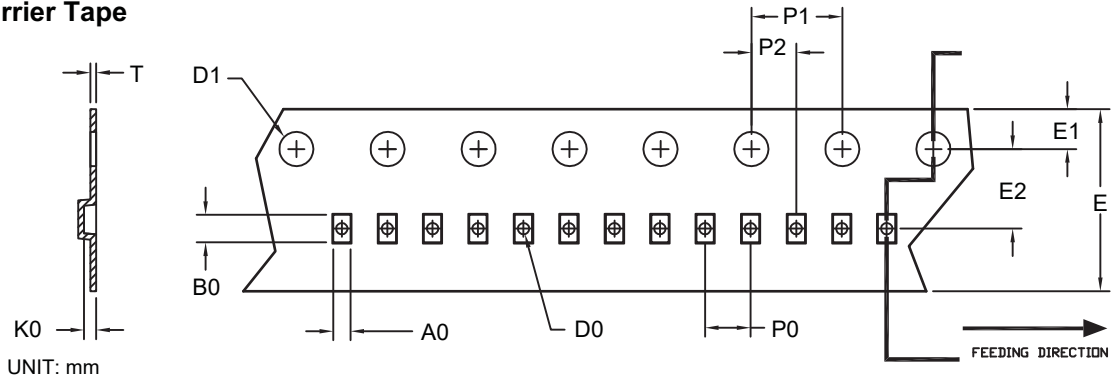

Option	Package	A0	B0	K0	D0	D1	E	E1	E2	P0	P1	P2	T
A	DFN 1.0x0.6/ DFN 1.0x0.6A (8 mm)	0.69 ±0.05	1.19 ±0.05	0.66 ±0.05	0.40 ±0.05	1.50 ±0.10	8.00 +0.3/-0.1	1.75 ±0.10	3.50 ±0.05	2.00 ±0.05	4.00 ±0.10	2.00 ±0.05	0.23 ±0.02
B	DFN 1.0x0.6/ DFN 1.0x0.6A (8 mm)	0.65 ±0.04	1.05 ±0.04	0.61 ±0.04	0.40 ±0.05	1.50 ±0.10	8.00 +0.3/-0.1	1.75 ±0.10	3.50 ±0.05	2.00 ±0.10	4.00 ±0.10	2.00 ±0.05	0.20 ±0.05

Reel

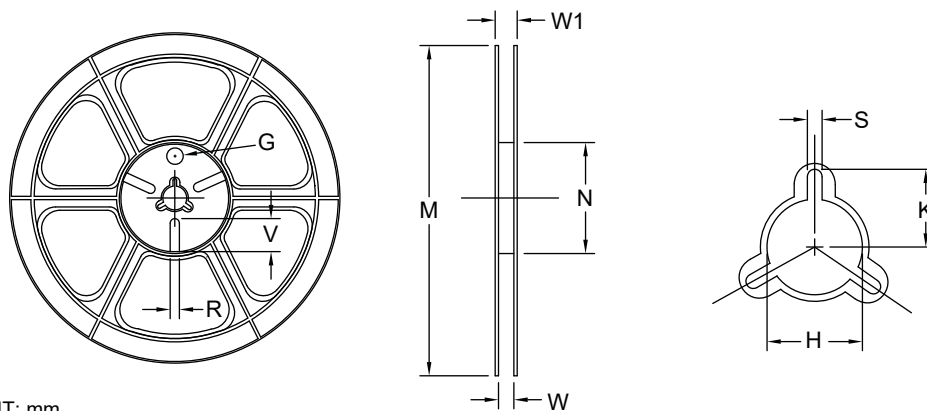

Tape Size	Reel Size	M	N	W	W1	H	K	S	G	R	V
8mm	ø178	ø178 ±0.5	ø55 ±1	8.4 +1.5/-0	Max. 14.4	ø13.0 ±0.5	Max. 10.1	2.0 ±0.5	N/A	N/A	N/A

Leader / Trailer & Orientation

TVS
Unit Per Reel:
10000pcs

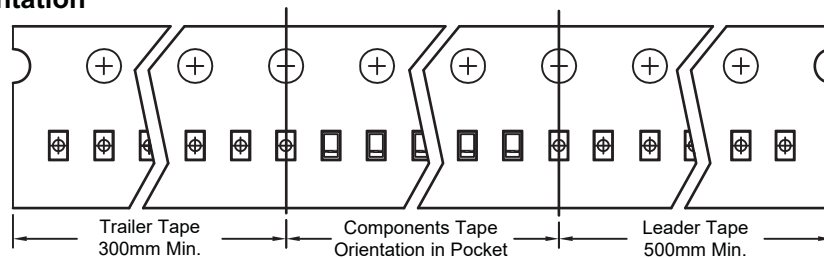

Part Marking

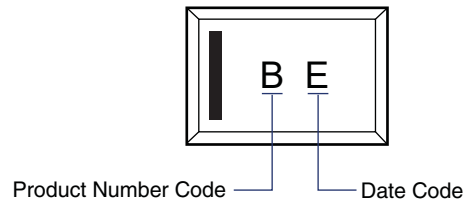

LEGAL DISCLAIMER

Applications or uses as critical components in life support devices or systems are not authorized. AOS does not assume any liability arising out of such applications or uses of its products. AOS reserves the right to make changes to product specifications without notice. It is the responsibility of the customer to evaluate suitability of the product for their intended application. Customer shall comply with applicable legal requirements, including all applicable export control rules, regulations and limitations.

AOS' products are provided subject to AOS' terms and conditions of sale which are set forth at:

http://www.aosmd.com/terms_and_conditions_of_sale

LIFE SUPPORT POLICY

ALPHA AND OMEGA SEMICONDUCTOR PRODUCTS ARE NOT AUTHORIZED FOR USE AS CRITICAL COMPONENTS IN LIFE SUPPORT DEVICES OR SYSTEMS.

As used herein:

1. Life support devices or systems are devices or systems which, (a) are intended for surgical implant into the body or (b) support or sustain life, and (c) whose failure to perform when properly used in accordance with instructions for use provided in the labeling, can be reasonably expected to result in a significant injury of the user.
2. A critical component in any component of a life support, device, or system whose failure to perform can be reasonably expected to cause the failure of the life support device or system, or to affect its safety or effectiveness.