

FAST RECOVERY RECTIFIER DIODES

- VERY LOW REVERSE RECOVERY TIME
- VERY LOW SWITCHING LOSSES
- LOW NOISE TURN-OFF SWITCHING

SUITABLE APPLICATIONS

- The BYT 16 P can be used:

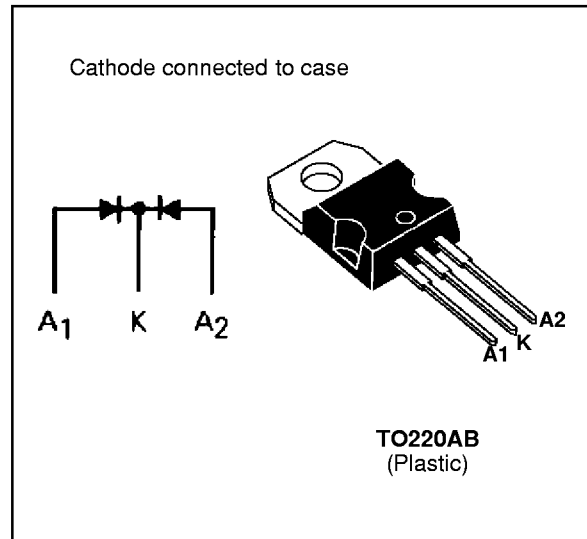
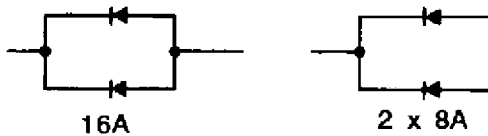

ABSOLUTE MAXIMUM RATINGS (limiting values)

Symbol	Parameter		Value	Unit
I_{FRM}	Repetitive Peak Forward Current	$t_p \leq 10\mu s$	130	A
$I_{F(RMS)}$	RMS Forward Current		30	A
$I_{F(AV)}$	Average Forward Current	$T_{case} = 100^\circ C$ $\delta = 0.5$	16	A
I_{FSM}	Surge non Repetitive Forward Current	$t_p = 10ms$ Sinusoidal	100	A
P	Power Dissipation	$T_{case} = 100^\circ C$	25	W
T_{stg} T_j	Storage and Junction Temperature Range		- 40 to + 150 - 40 to + 150	$^\circ C$

Symbol	Parameter	BYT 16P-			Unit
		200	300	300	
V_{RRM}	Repetitive Peak Reverse Voltage	200	300	400	V
V_{RSM}	Non Repetitive Peak Reverse Voltage	220	330	440	V

THERMAL RESISTANCE

Symbol	Test Conditions		Value	Unit
$R_{th(j-c)}$	Junction-case	per leg total	3.75 2	$^\circ C/W$
$R_{th(c)}$	Coupling		0.25	$^\circ C/W$

ELECTRICAL CHARACTERISTICS

STATIC CHARACTERISTICS

Symbol	Test Conditions		Min.	Typ.	Max.	Unit
I _R	T _j = 25°C	V _R = V _{RRM}			15	μA
	T _j = 100°C				2.5	mA
V _F	T _j = 25°C	I _F = 8A			1.5	V
	T _j = 100°C				1.4	

RECOVERY CHARACTERISTICS

Symbol	Test Conditions			Min.	Typ.	Max.	Unit
t _{rr}	T _j = 25°C	I _F = 1A	di _F /dt = - 15A/μs			75	ns
		I _F = 0.5A	I _R = 1A				

TURN-OFF SWITCHING CHARACTERISTICS (Without Series Inductance)

Symbol	Test Conditions		Min.	Typ.	Max.	Unit
t _{IRM}	di _F /dt = - 32A/μs	V _{CC} = 200 V I _F = 8A L _p ≤ 0.05μH T _j = 100°C See figure 11			75	ns
	di _F /dt = - 64A/μs			50		
I _{RM}	di _F /dt = - 32A/μs				2.2	A
	di _F /dt = - 64A/μs			2.8		

TURN-OFF OVERVOLTAGE COEFFICIENT (With Series Inductance)

Symbol	Test Conditions			Min.	Typ.	Max.	Unit
$C = \frac{V_{RP}}{V_{CC}}$	T _j = 100°C	V _{CC} = 120V	I _F = I _{F(AV)} See note		3.3		
	di _F /dt = - 8A/μs	L _p = 9μH	See figure 12				

Note : Applicable to BYT 16P-400 only

To evaluate the conduction losses use the following equations:

$$V_F = 1.1 + 0.024 I_F$$

$$P = 1.1 \times I_{F(AV)} + 0.024 I_{F(RMS)}^2 \text{ (1 leg)}$$

$$P = 1.1 \times I_{F(AV)} + 0.012 I_{F(RMS)}^2 \text{ (2 legs)}$$

Figure 1. Low frequency power losses versus average current

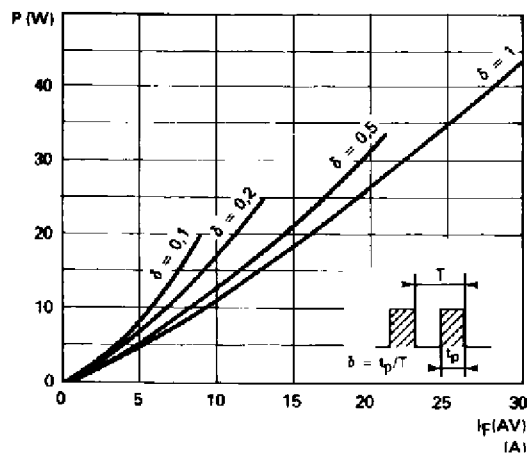

Figure 2. Peak current versus form factor

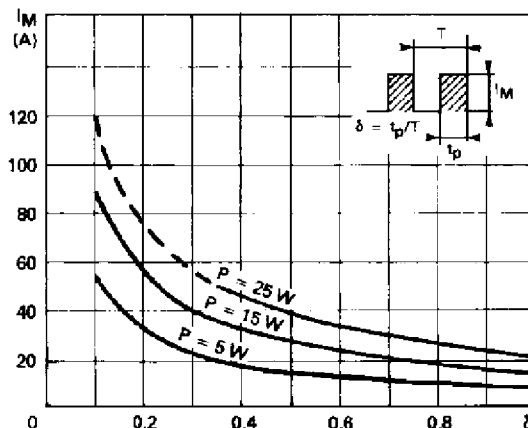

Figure 3. Non repetitive peak surge current versus overload duration

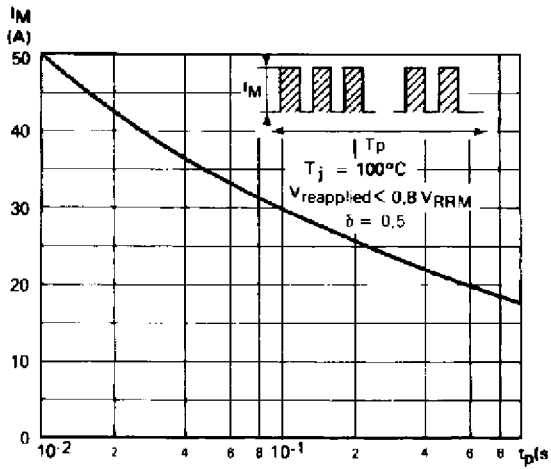

Figure 5. Voltage drop versus forward current

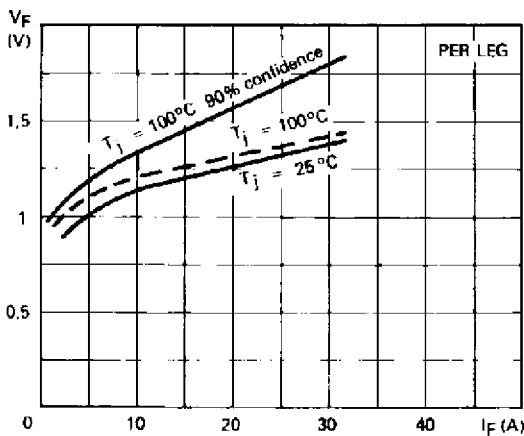

Figure 7. Recovery time versus di_F/dt

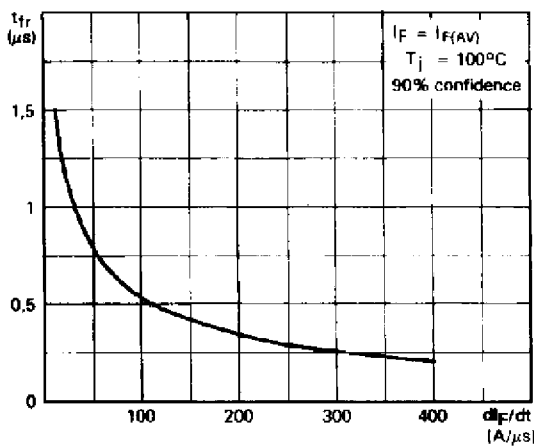

Figure 4. Thermal impedance versus pulse width

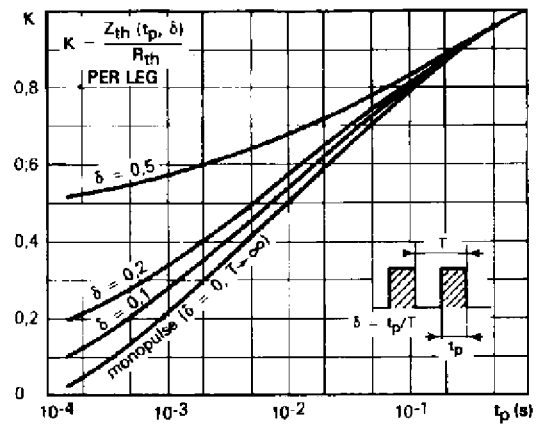

Figure 6. Recovery charge versus di_F/dt

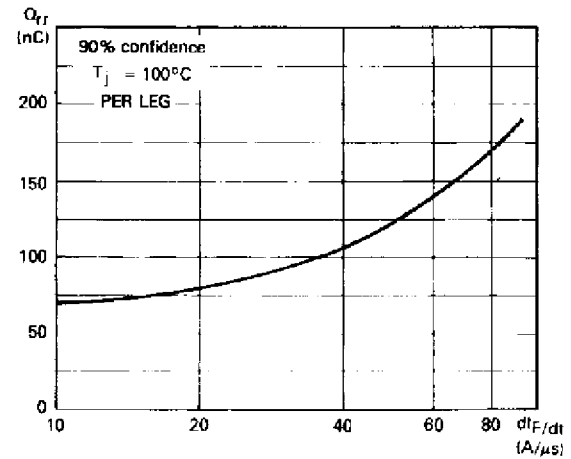

Figure 8. Peak reverse current versus di_F/dt

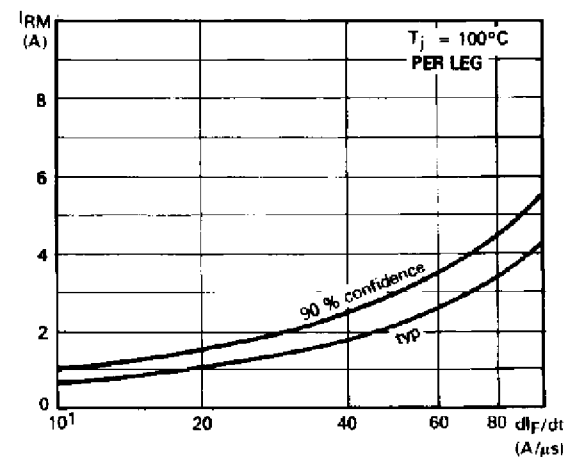

Figure 9. Peak forward voltage versus di_F/dt .

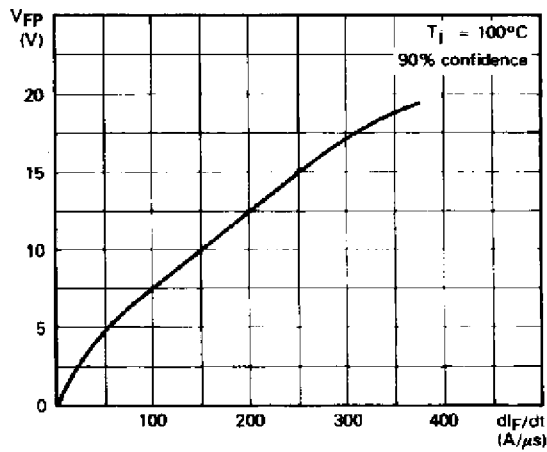

Figure 10. Dynamic parameters versus junction temperature.

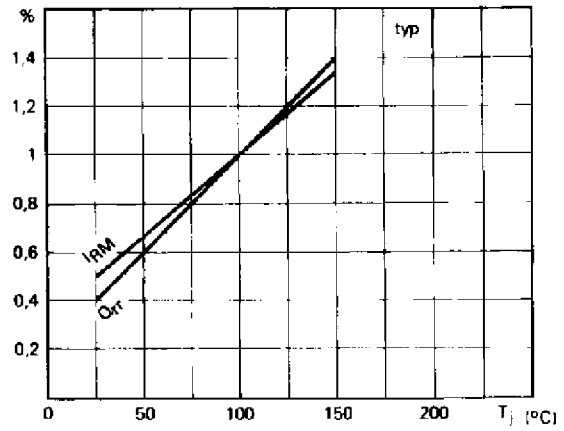

Figure 11. Turn-off switching characteristics (without series inductance).

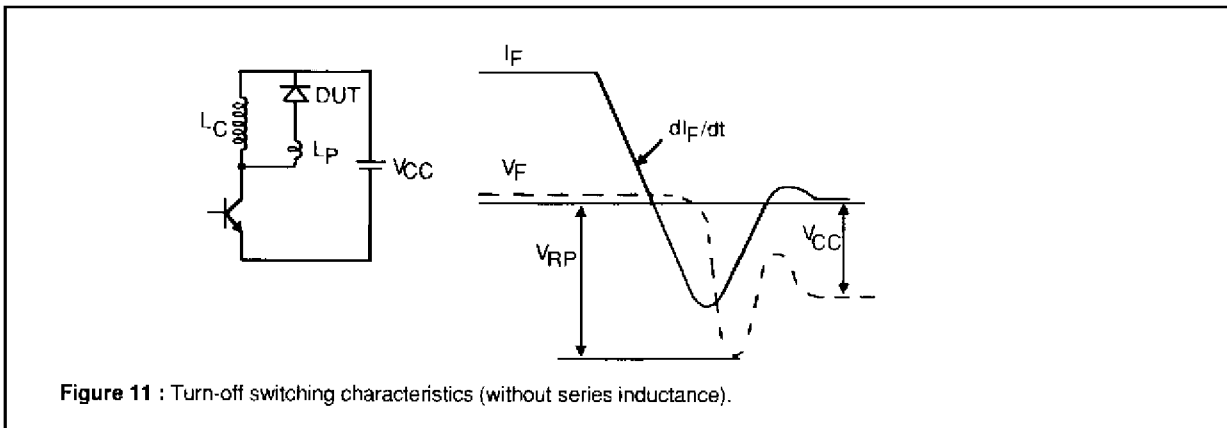
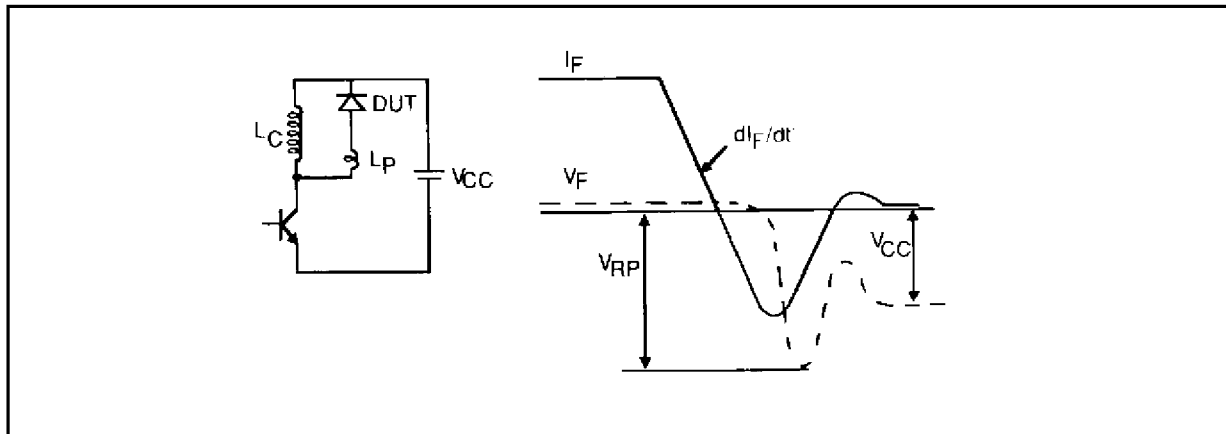
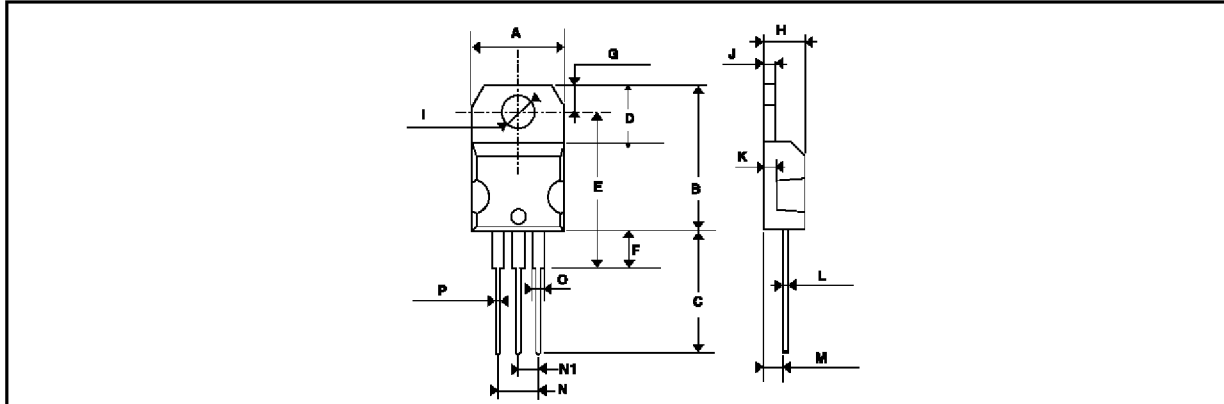

Figure 11 : Turn-off switching characteristics (without series inductance).

Figure 12. Turn-off switching characteristics (without series inductance)



PACKAGE MECHANICAL DATA :
TO 220 AB Plastic



REF.	DIMENSIONS			
	Millimeters		Inches	
	Min.	Max.	Min.	Max.
A	10.0	10.4	0.393	0.409
B	15.2	15.9	0.598	0.626
C	13	14	0.511	0.551
D	6.2	6.6	0.244	0.260
E	16.4 typ.		0.645 typ.	
F	3.5	4.2	0.137	0.165
G	2.65	2.95	0.104	0.116
H	4.4	4.6	0.173	0.181
I	3.75	3.85	0.147	0.151
J	1.23	1.32	0.048	0.051
K	1.27 typ.		0.050 typ.	
L	0.49	0.70	0.019	0.027
M	2.4	2.72	0.094	0.107
N	4.95	5.15	0.194	0.203
N1	2.40	2.70	0.094	0.106
O	1.14	1.70	0.044	0.067
P	0.61	0.88	0.024	0.034

Cooling method: by conduction (method C)
Marking: type number
Weight: 2.47g

Information furnished is believed to be accurate and reliable. However, SGS-THOMSON Microelectronics assumes no responsibility for the consequences of use of such information nor for any infringement of patents or other rights of third parties which may result from its use. No license is granted by implication or otherwise under any patent or patent rights of SGS-THOMSON Microelectronics. Specifications mentioned in this publication are subject to change without notice. This publication supersedes and replaces all information previously supplied. SGS-THOMSON Microelectronics products are not authorized for use as critical components in life support devices or systems without express written approval of SGS-THOMSON Microelectronics.

© 1994 SGS-THOMSON Microelectronics - Printed in Italy - All rights reserved.

SGS-THOMSON Microelectronics GROUP OF COMPANIES

Australia - Brazil - France - Germany - Hong Kong - Italy - Japan - Korea - Malaysia - Malta - Morocco - The Netherlands
Singapore - Spain - Sweden - Switzerland - Taiwan - United Kingdom - U.S.A.