

Bias Resistor Transistor

NPN Silicon Surface Mount Transistor with Monolithic Bias Resistor Network

This new series of digital transistors is designed to replace a single device and its external resistor bias network. The BRT (Bias Resistor Transistor) contains a single transistor with a monolithic bias network consisting of two resistors; a series base resistor and a base-emitter resistor. The BRT eliminates these individual components by integrating them into a single device. The use of a BRT can reduce both system cost and board space. The device is housed in the SC-70/SOT-323 package which is designed for low power surface mount applications.

- Simplifies Circuit Design
 - Reduces Board Space
 - Reduces Component Count
 - The SC-70/SOT-323 package can be soldered using wave or reflow. The modified gull-winged leads absorb thermal stress during soldering eliminating the possibility of damage to the die.
 - Available in 8 mm embossed tape and reel
- Use the Device Number to order the 7 inch/3000 unit reel.

MUN5211RT1 SERIES

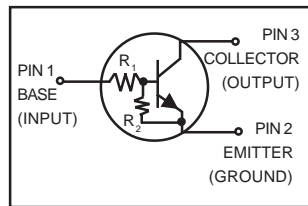
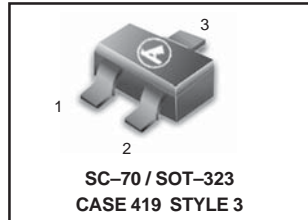

MARKING DIAGRAM

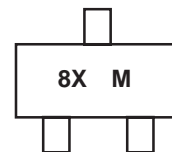

8x = Specific Device Code
x = (See Marking Table)
M = Date Code

DEVICE MARKING INFORMATION

See specific marking information in the device marking table on page 2 of this data sheet.

MAXIMUM RATINGS ($T_A = 25^\circ\text{C}$ unless otherwise noted)

Rating	Symbol	Value	Unit
Collector-Base Voltage	V_{CBO}	50	Vdc
Collector-Emitter Voltage	V_{CEO}	50	Vdc
Collector Current	I_C	100	mAdc

THERMAL CHARACTERISTICS

Characteristic	Symbol	Max	Unit
Total Device Dissipation $T_A = 25^\circ\text{C}$ Derate above 25°C	P_D	202 (Note 1.) 310 (Note 2.) 1.6 (Note 1.) 2.5 (Note 2.)	mW mW/ $^\circ\text{C}$
Thermal Resistance – Junction-to-Ambient	$R_{\theta JA}$	618 (Note 1.) 403 (Note 2.)	$^\circ\text{C/W}$
Thermal Resistance – Junction-to-Lead	$R_{\theta JL}$	280 (Note 1.) 332 (Note 2.)	$^\circ\text{C/W}$
Junction and Storage Temperature Range	T_J, T_{stg}	-55 to +150	$^\circ\text{C}$

1. FR-4 @ Minimum Pad
2. FR-4 @ 1.0 x 1.0 inch Pad

MUN5211RT1 Series**DEVICE MARKING AND RESISTOR VALUES**

Device	Package	Marking	R1 (K)	R2 (K)	Shipping
MUN5211RT1	SC-70/SOT-323	8A	10	10	3000/Tape & Reel
MUN5212RT1	SC-70/SOT-323	8B	22	22	3000/Tape & Reel
MUN5213RT1	SC-70/SOT-323	8C	47	47	3000/Tape & Reel
MUN5214RT1	SC-70/SOT-323	8D	10	47	3000/Tape & Reel
MUN5215RT1 (Note 3.)	SC-70/SOT-323	8E	10	∞	3000/Tape & Reel
MUN5216RT1 (Note 3.)	SC-70/SOT-323	8F	4.7	∞	3000/Tape & Reel
MUN5230RT1 (Note 3.)	SC-70/SOT-323	8G	1.0	1.0	3000/Tape & Reel
MUN5231RT1 (Note 3.)	SC-70/SOT-323	8H	2.2	2.2	3000/Tape & Reel
MUN5232RT1 (Note 3.)	SC-70/SOT-323	8J	4.7	4.7	3000/Tape & Reel
MUN5233RT1 (Note 3.)	SC-70/SOT-323	8K	4.7	47	3000/Tape & Reel
MUN5234RT1 (Note 3.)	SC-70/SOT-323	8L	22	47	3000/Tape & Reel
MUN5235RT1 (Note 3.)	SC-70/SOT-323	8M	2.2	47	3000/Tape & Reel
MUN5236RT1 (Note 3.)	SC-70/SOT-323	8N	100	100	3000/Tape & Reel
MUN5237RT1 (Note 3.)	SC-70/SOT-323	8P	47	22	3000/Tape & Reel

3. New devices. Updated curves to follow in subsequent data sheets.

MUN5211RT1 Series

ELECTRICAL CHARACTERISTICS ($T_A = 25^\circ\text{C}$ unless otherwise noted) (Continued)

Characteristic	Symbol	Min	Typ	Max	Unit
ON CHARACTERISTICS (Note 5.) (Continued)					
Output Voltage (off) ($V_{CC} = 5.0\text{ V}$, $V_B = 0.5\text{ V}$, $R_L = 1.0\text{ k}\Omega$) ($V_{CC} = 5.0\text{ V}$, $V_B = 0.050\text{ V}$, $R_L = 1.0\text{ k}\Omega$) ($V_{CC} = 5.0\text{ V}$, $V_B = 0.25\text{ V}$, $R_L = 1.0\text{ k}\Omega$)	V_{OH}	4.9	–	–	Vdc
Input Resistor	R_1	7.0	10	13	k Ω
MUN5211RT1		15.4	22	28.6	
MUN5212RT1		32.9	47	61.1	
MUN5213RT1		7.0	10	13	
MUN5214RT1		7.0	10	13	
MUN5215RT1		3.3	4.7	6.1	
MUN5216RT1		0.7	1.0	1.3	
MUN5230RT1		1.5	2.2	2.9	
MUN5231RT1		3.3	4.7	6.1	
MUN5232RT1		3.3	4.7	6.1	
MUN5233RT1		15.4	22	28.6	
MUN5234RT1		1.54	2.2	2.86	
MUN5235RT1		70	100	130	
MUN5236RT1		32.9	47	61.1	
Resistor Rati	R_1/R_2	0.8	1.0	1.2	
MUN5211RT1/MUN5212RT1/MUN5213RT1/ MUN5236RT1		0.17	0.21	0.25	
MUN5214RT1		–	–	–	
MUN5215RT1/MUN5216RT1		0.8	1.0	1.2	
MUN5230RT1/MUN5231RT1/MUN5232RT1		0.055	0.1	0.185	
MUN5233RT1		0.38	0.47	0.56	
MUN5234RT1		0.038	0.047	0.056	
MUN5235RT1		1.7	2.1	2.6	
MUN5237RT1					

5. Pulse Test: Pulse Width < 300 μs , Duty Cycle < 2.0%

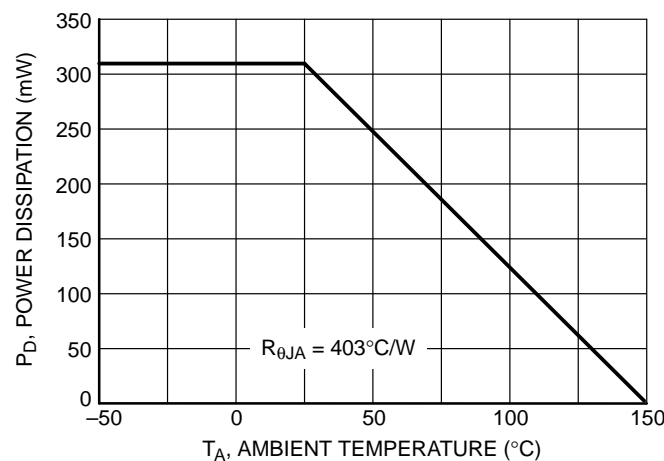

Figure 1. Derating Curve

MUN5211RT1 Series

TYPICAL ELECTRICAL CHARACTERISTICS – MUN5211RT1

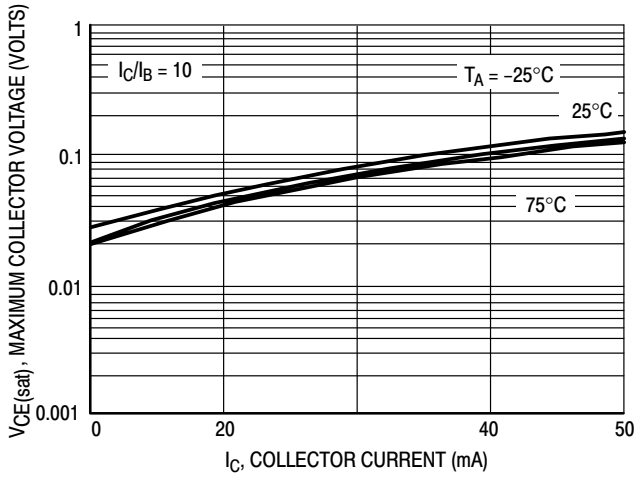

Figure 2. $V_{CE(sat)}$ versus I_C

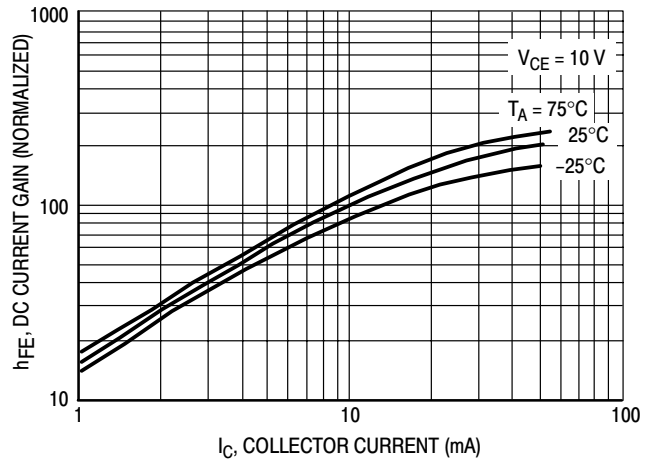

Figure 3. DC Current Gain

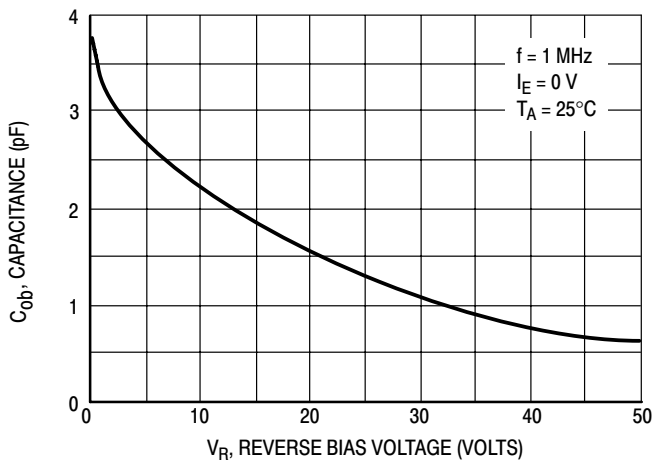

Figure 4. Output Capacitance

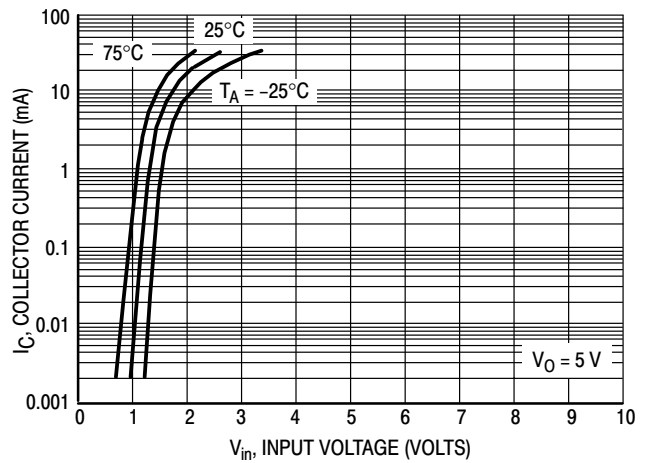

Figure 5. Output Current versus Input Voltage

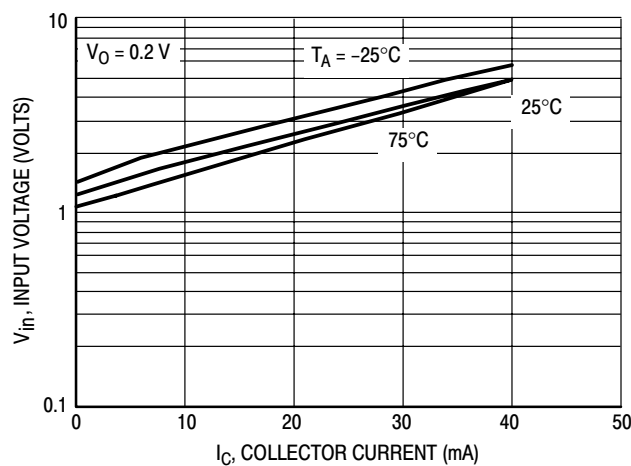

Figure 6. Input Voltage versus Output Current

MUN5211RT1 Series

TYPICAL ELECTRICAL CHARACTERISTICS – MUN5212RT1

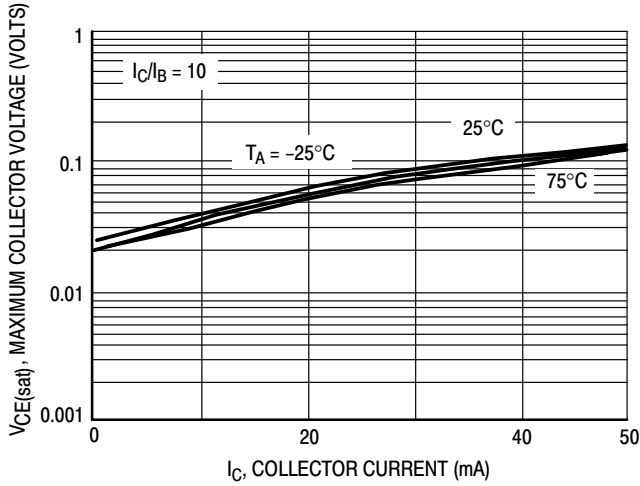

Figure 7. $V_{CE(sat)}$ versus I_C

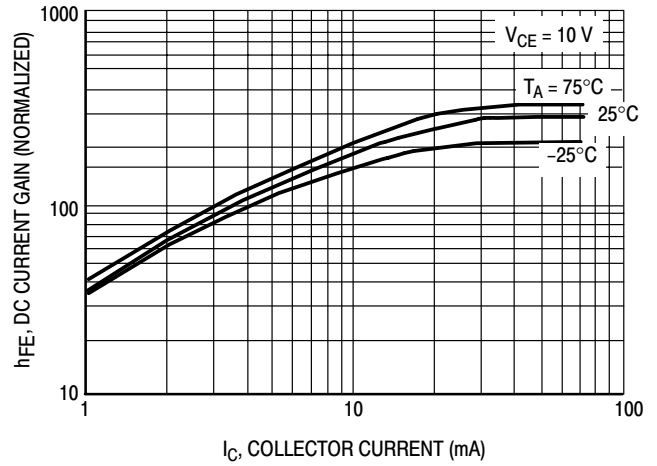

Figure 8. DC Current Gain

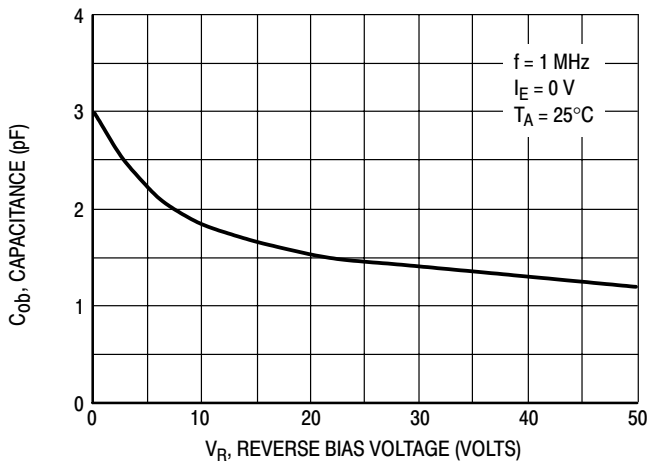

Figure 9. Output Capacitance

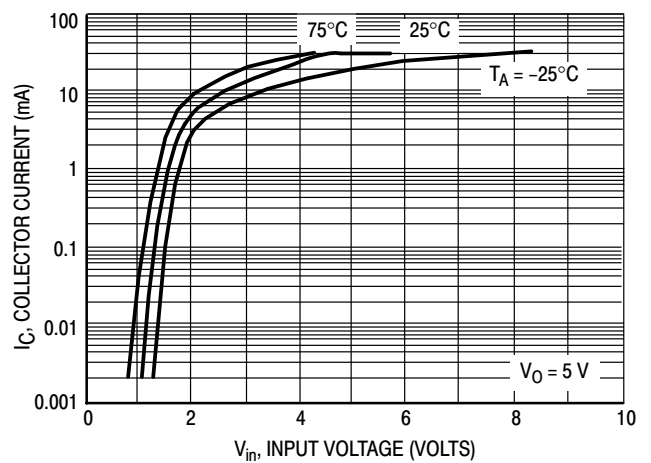

Figure 10. Output Current versus Input Voltage

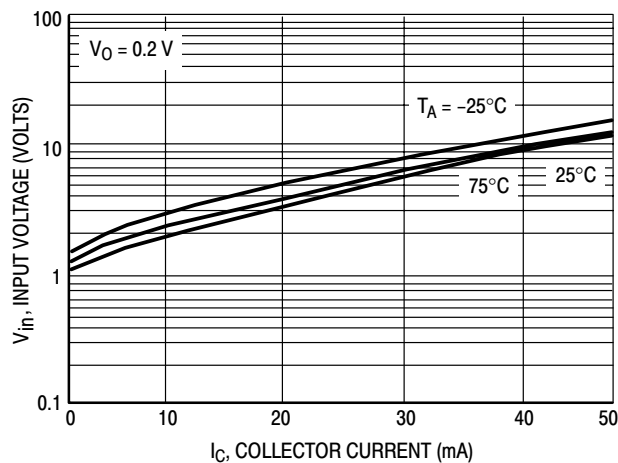

Figure 11. Input Voltage versus Output Current

MUN5211RT1 Series

TYPICAL ELECTRICAL CHARACTERISTICS – MUN5213RT1

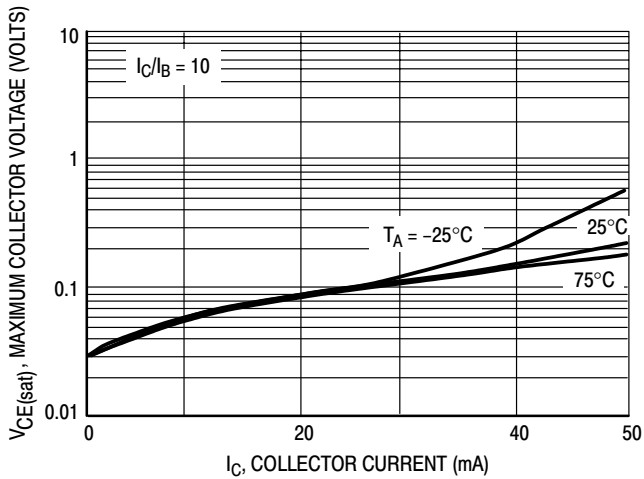

Figure 12. $V_{CE(sat)}$ versus I_C

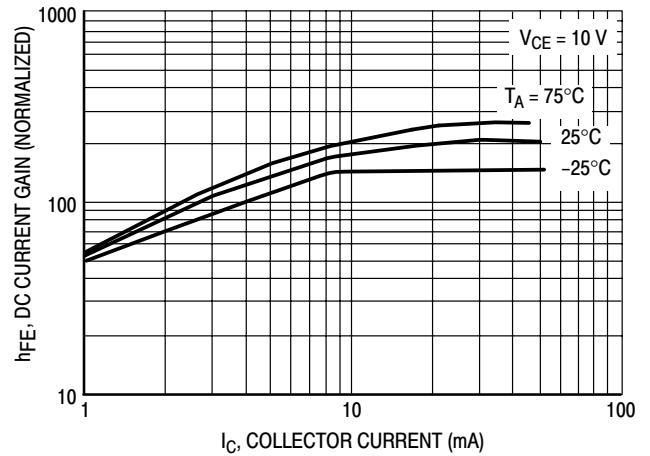

Figure 13. DC Current Gain

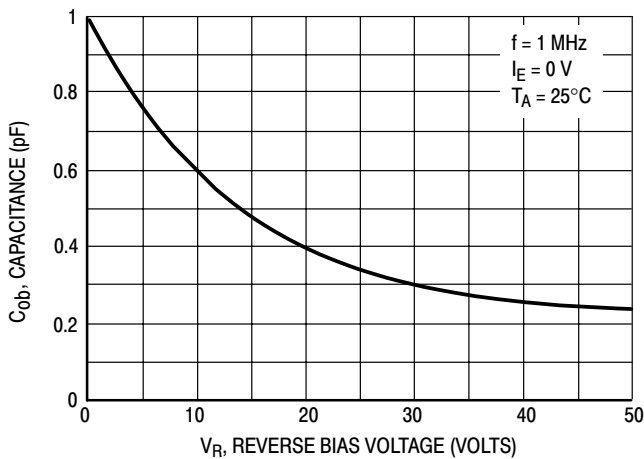

Figure 14. Output Capacitance

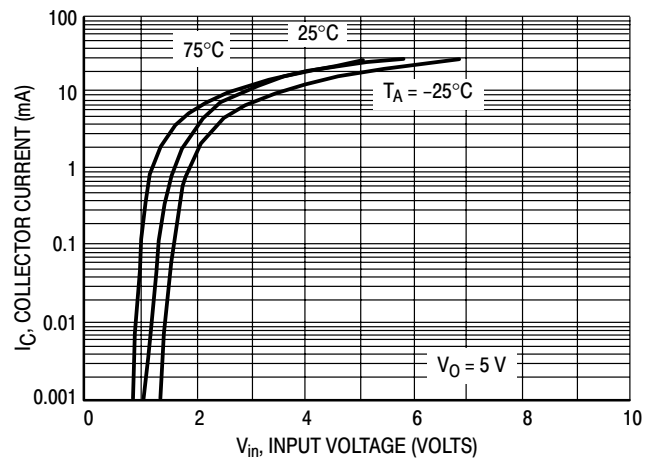

Figure 15. Output Current versus Input Voltage

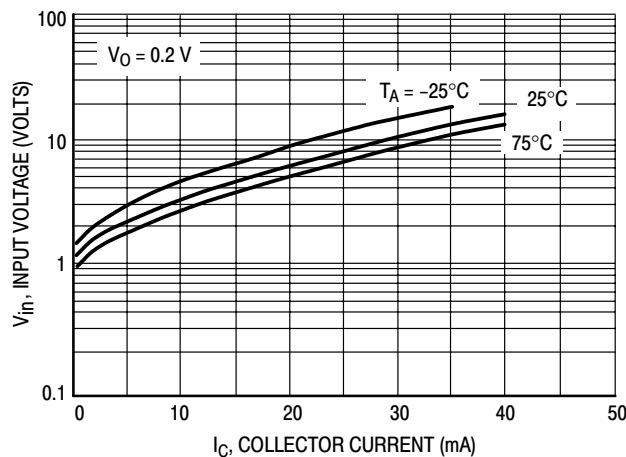

Figure 16. Input Voltage versus Output Current

MUN5211RT1 Series

TYPICAL ELECTRICAL CHARACTERISTICS – MUN5214RT1

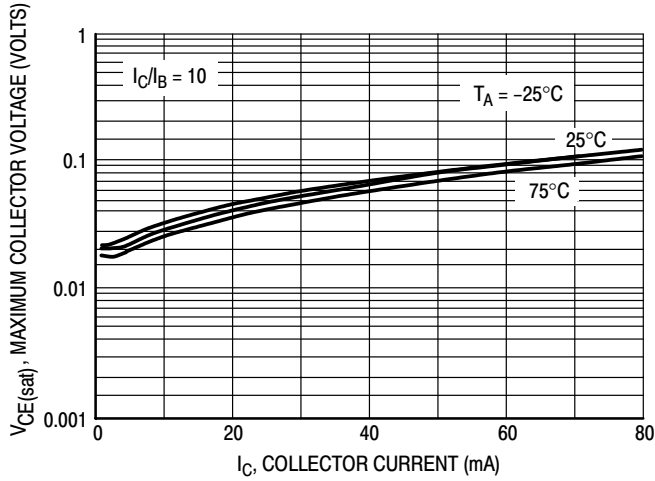

Figure 17. $V_{CE(sat)}$ versus I_C

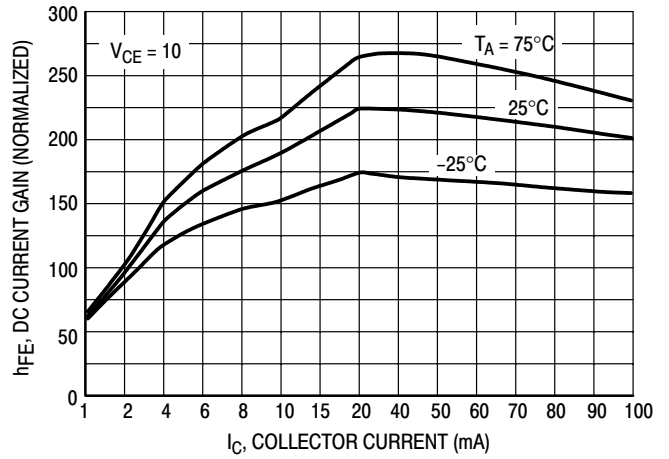

Figure 18. DC Current Gain

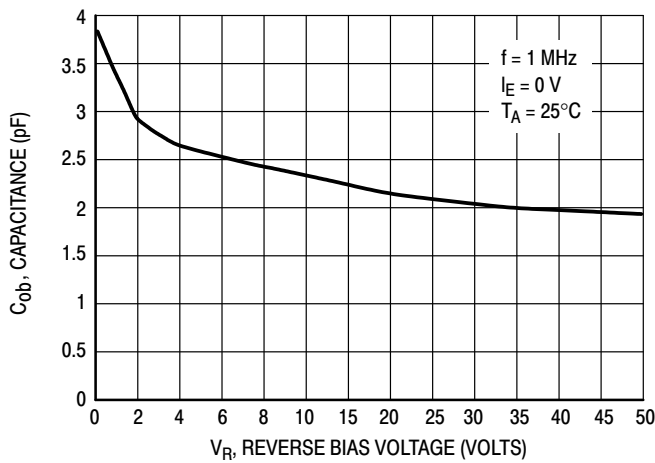

Figure 19. Output Capacitance

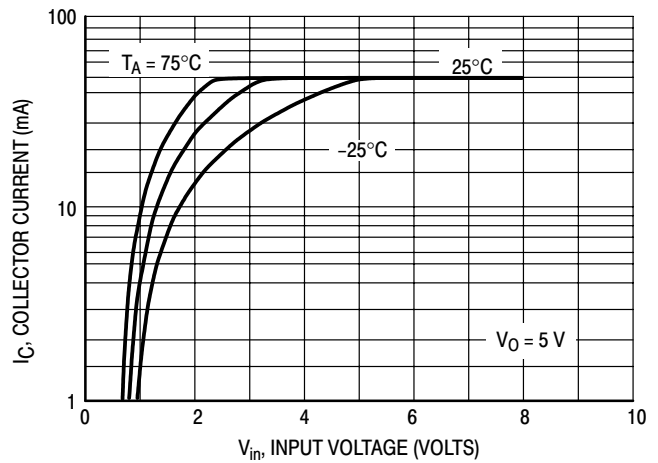

Figure 20. Output Current versus Input Voltage

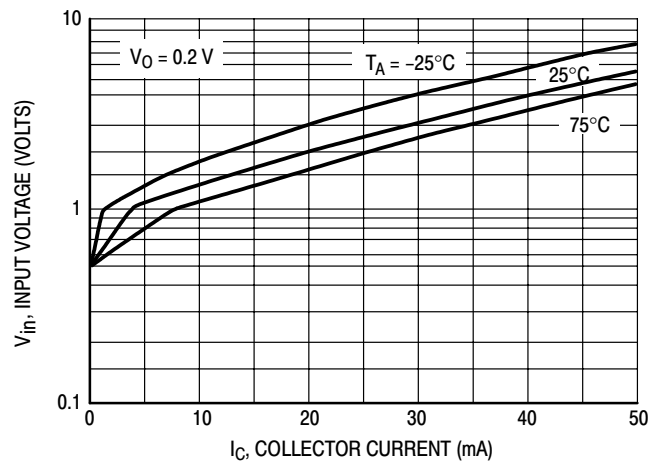

Figure 21. Input Voltage versus Output Current

MUN5211RT1 Series

TYPICAL APPLICATIONS FOR NPN BRTs

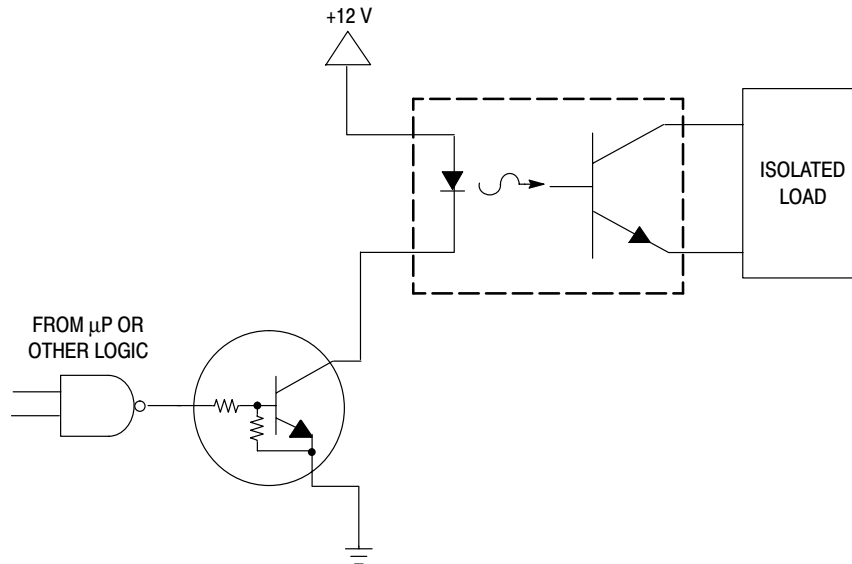

Figure 22. Level Shifter: Connects 12 or 24 Volt Circuits to Logic

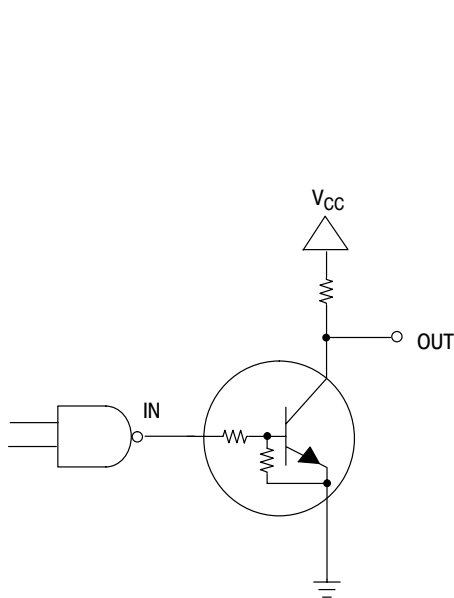

Figure 23. Open Collector Inverter: Inverts the Input Signal

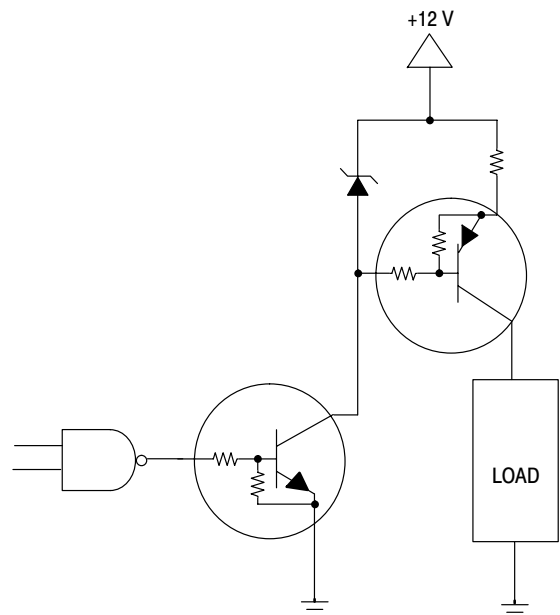

Figure 24. Inexpensive, Unregulated Current Source