

GD54/74HC34, GD54/74HCT34

HEX BUFFERS

General Description

These devices are identical in pinout to the 54/74LS34. They contain six independent noninverting buffers. Especially, the HCT 34 can be used for interfacing between TTL and NMOS components and standard CMOS devices. These devices are characterized for operation over wide temperature ranges to meet industry and military specifications.

Features

- Low Power consumption characteristic of CMOS devices
- Output drive capability: 10 LS TTL Loads Min.
- Operating speed superior to LS TTL
- Wide operating voltage range: for HC 2 to 6 volts
for HCT 4.5 to 5.5 volts
- Low input current: 1 μ A Max.
- Low quiescent current: 20 μ A Max. (74HC)
- High noise immunity characteristic of CMOS
- Diode protection on all inputs

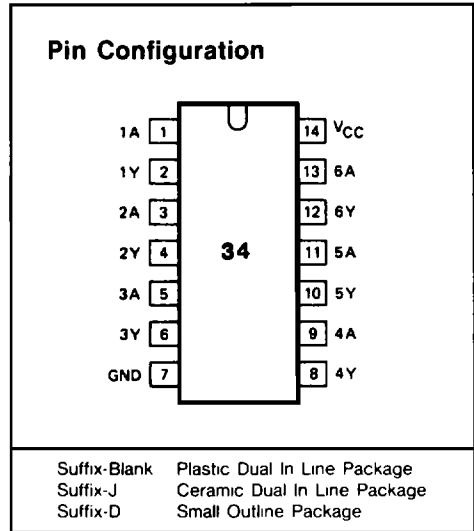

Logic Diagram

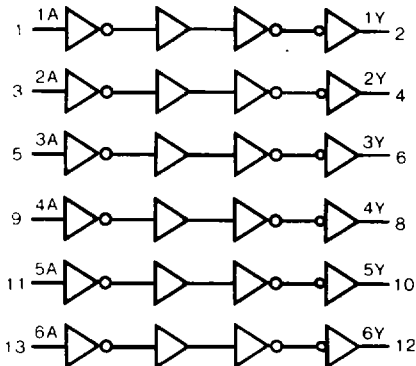

Fig. 1 Logic Diagram

Function Table

INPUT	OUTPUT
nA	nY
H	H
L	L

H= HIGH voltage level
L= LOW voltage level

Absolute Maximum Ratings

SYMBOL	PARAMETER	CONDITIONS	MIN.	MAX.	UNIT
V_{CC}	DC Supply voltage		-0.5	+7	V
I_{IK}, I_{OK}	DC input or output diode current	for $V_I < -0.5$ or $V_I > V_{CC} + 0.5V$		20	mA
I_O	DC output source or sink current	for $-0.5V < V_O < V_{CC} + 0.5V$		25	mA
I_{CC}	DC V_{CC} or GND current			50	mA
T_{stg}	Storage temperature range		-65	150	°C
P_D	Power dissipation per package	above +70°C. derate linearly with 8mW/K		500	mW
T_L	Lead temperature	At distance 1/16 ± 1/32 in from case for 60 sec(CERAMIC) 10 sec(PLASTIC)		300 260	°C

Recommended Operating Conditions

CHARACTERISTIC	LIMITS		UNITS
	MIN.	MAX	
Supply-Voltage Range V_{CC} : GD54/74HC Types GD54/74HCT Types	2 4.5	6 5.5	V
DC Input or Output Voltage V_I, V_O	0	V_{CC}	V
Operating Temperature T_A : GD74 Types GD54 Types	-40 -55	+85 +125	°C
Input Rise and Fall times t_r, t_f : GD54/74HC Types at 2V at 4.5V at 6V GD54/74HCT Types at 4.5V		1000 500 400 500	ns

DC Electrical Characteristics for HC

SYMBOL	PARAMETER	TEST CONDITION	V _{CC} (V)	T _A =25°C			GD74HC34		GD54HC34		UNIT	
				MIN.	TYP.	MAX.	MIN.	MAX.	MIN.	MAX.		
V _{IH}	HIGH level input Voltage		2.0	1.5			1.5		1.5		V	
			4.5	3.15			3.15		3.15			
			6.0	4.2			4.2		4.2			
V _{IL}	LOW level input voltage		2.0			0.3		0.3		0.3	V	
			4.5			0.9		0.9		0.9		
			6.0			1.2		1.2		1.2		
V _{OH}	HIGH level output voltage	V _{IN} =V _{IH}	I _{OH} =-20μA	2.0	1.9	2.0		1.9		1.9	V	
				4.5	4.4	4.5		4.4		4.4		
				6.0	5.9	6.0		5.9		5.9		
		or V _{IL}	I _{OH} =-4mA	4.5	3.98	4.3		3.84		3.7		
				6.0	5.48	5.2		5.34		5.2		
V _{OL}	LOW level output voltage	V _{IN} =V _{IH}	I _{OL} =20μA	2.0			0.1		0.1		V	
				4.5			0.1		0.1			0.1
				6.0			0.1		0.1			0.1
		or V _{IL}	I _{OL} =4mA	4.5		0.17	0.26		0.33			0.4
				6.0		0.15	0.26		0.33			0.4
I _{IN}	Input leakage Current	V _{IN} =V _{CC} or GND	6.0			0.1		1.0		1.0	μA	
I _{CC}	Quiescent Supply Current	V _{IN} =V _{CC} or GND I _{out} =0μA	6.0			2		20		40	μA	

DC Electrical Characteristics for HCT

SYMBOL	PARAMETER	TEST CONDITION	V _{CC} (V)	T _A =25°C			GD74HCT34		GD54HCT34		UNIT	
				MIN.	TYP.	MAX.	MIN.	MAX.	MIN.	MAX.		
V _{IH}	HIGH level input Voltage		4.5								V	
			to 5.5	2.0			2.0		2.0			
V _{IL}	LOW level input voltage		4.5								V	
			to 5.5			0.8		0.8		0.8		
V _{OH}	HIGH level output voltage	V _{IN} =V _{IH}	I _{OH} =-20μA	4.5	4.4	4.5		4.4		4.4	V	
				4.5	3.98	4.3		3.84		3.7		
				6.0								
		or V _{IL}	I _{OH} =-4mA	4.5								
				6.0								
V _{OL}	LOW level output voltage	V _{IN} =V _{IH}	I _{OL} =20μA	4.5			0.1		0.1		V	
				4.5			0.1		0.1			
				6.0			0.1		0.1			
		or V _{IL}	I _{OL} =4mA	4.5		0.17	0.26		0.33			0.4
				6.0								
I _{IN}	Input leakage Current	V _{IN} =V _{CC} or GND	5.5			0.1		1.0		1.0	μA	
I _{CC}	Quiescent Supply Current	V _{IN} =V _{CC} or GND I _{out} =0μA	5.5			2		20		40	μA	

AC Characteristics for HC: $t_r=t_f=6\text{ns}$ $C_L=50\text{ pF}$

SYMBOL	PARAMETER	V_{CC} (V)	$T_A=25^\circ\text{C}$			GD74HC34		GD54HC34		UNIT
			MIN.	TYP.	MAX.	MIN.	MAX.	MIN.	MAX.	
t_{PLH}' t_{PHL}	Propagation Delay Time nA to nY	2.0		25	80		105		125	ns
		4.5		8	16		21		26	
		6.0		7	14		18		23	
t_{TLH}' t_{THL}	Output Transition Time	2.0		25	70		85		100	ns
		4.5		8	15		18		22	
		6.0		7	13		16		19	

AC Characteristics for HCT: $t_r=t_f=6\text{ns}$ $C_L=50\text{ pF}$

SYMBOL	PARAMETER	V_{CC} (V)	$T_A=25^\circ\text{C}$			GD74HCT34		GD54HCT34		UNIT
			MIN.	TYP.	MAX.	MIN.	MAX.	MIN.	MAX.	
t_{PLH}' t_{PHL}	Propagation Delay Time nA to nY	4.5		12	20		24		28	ns
t_{TLH}' t_{THL}	Output Transition Time	4.5		8	15		19		22	ns

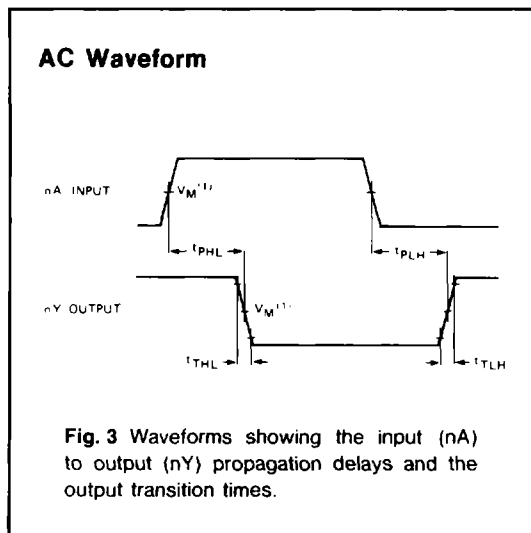

Note to AC waveform

- (1) HC $V_M=50\%$ $V_L=GND$ to V_{CC}
- HCT $V_M=1.3\text{V}$ $V_L=GND$ to 3V