



FCIconnect.com

Copyright FCI

PRODUCT NUMBER  
SEE NOTE 1

$\square$  .002:1

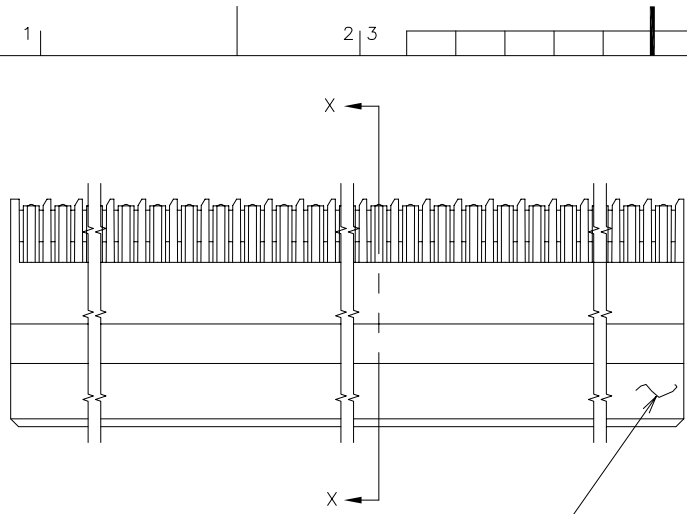

NOTE 6

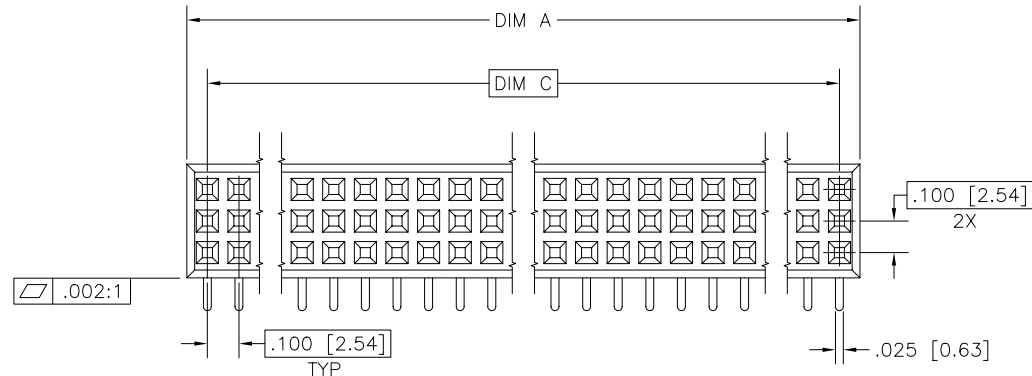

TYP

$\varnothing$  .020/.51 M A S B

AT TIPS

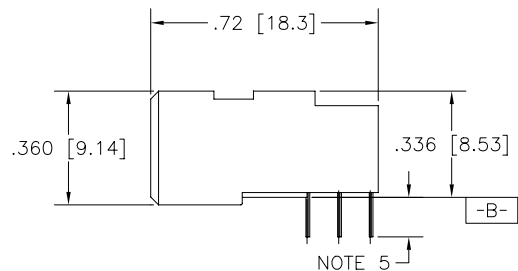

NOTE 5

mat'l. code NOTE 3		surface ISO 1302 ✓		tolerance ISO 406 ISO 1101		projection INCH/MM		product family HPC	
ltr	ecn no	dr	date	tolerances unless otherwise specified		INCH/MM		title	
C	v20609	MRC	4/07/92	angles	linear	.xx ±.01/.3		3 ROW R/A RECEPTACLE	
D	v30238	JM	1/18/93			.xxx ±.005/.13		CARD CONN. STYLE, S.T.B. 0 G.P.	
E	v31445	PDP	8/09/93	σ±2'		.xxxx ±.0020/.051		scale 1:1	
F	v41028	GAH	8/02/94	dr	M. FETROW	6/04/91		dwg no	
G	v90651	HTB	4/08/99	enr	S. CLARK	6/04/91		sheet 1 of 2 size	
H	v00256	JWS	1/20/00	chr	S. CLARK	6/04/91		50350 A3	
J	M06-0255	AEA	7/07/06	appd	S. CLARK	6/04/91		type Product Customer Drawing	
sheet index	revision	J	J						
	sheet	1	2						

form: A3

PRODUCT NUMBER	DIM.	LENGTH FORMULAS
SEE NOTE 1	DIM A	.100/2.54 X NO. OF COLUMNS + .03/.8
	DIM C	.100/2.54 X NO. OF COLUMNS - .100/2.54

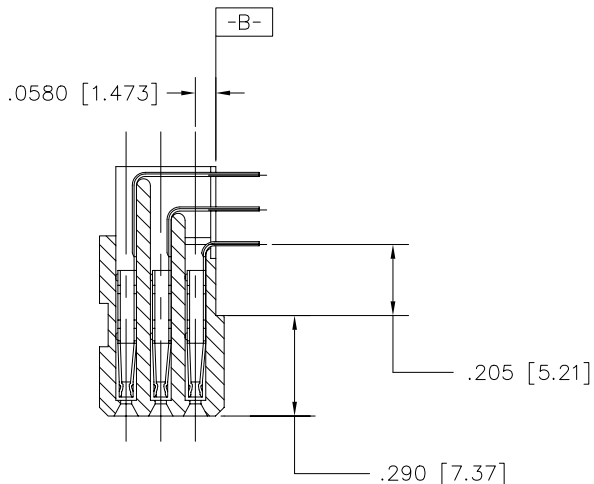

SECTION X-X  
SCALE 4:1

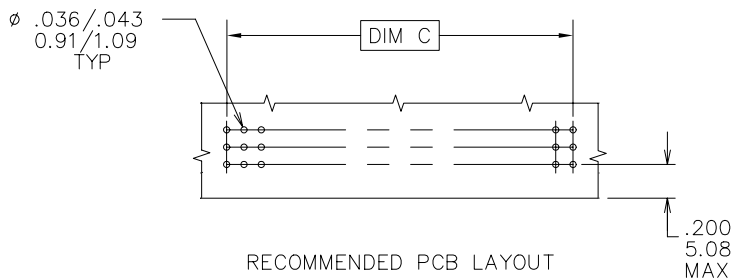

RECOMMENDED PCB LAYOUT  
ALL HOLES LOCATED ON .100/2.54 GRID  
UNLESS OTHERWISE SPECIFIED

NOTES:

- PRODUCT NUMBERING CODE:  
50350 - X YYY Z  
TAIL LENGTH (NOTE 5)  
NO. OF POSITIONS (NOTE 2)  
PLATING (NOTE 4)  
BASE NUMBER  
  
PRODUCT NUMBERING CODE FOR  
SELECT LOAD PART NUMBERS:  
50350 - XXYYY  
SEQUENCE NUMBER  
ALWAYS 'XX'  
BASE NUMBER
- THIS PRODUCT IS CONFIGURED IN SIZES OF  
10 THRU 50 COLUMNS IN INCREMENTS OF  
ONE.  
IE: 10,11,12,13,.....49,50.
- HOUSING MAT'L: GLASS AND MINERAL FILLED  
HIGH TEMP. THERMOPLASTIC. FLAME RETARDANT  
PER UL94V-0. COLOR: BLACK.  
CONTACT MAT'L: BeCu
- PLATING, CONTACT AREA OPTIONS:  
1 = 30u"/.76u GOLD  
3 = 50u"/1.27u GOLD  
5 = 30u"/.76u GXT  
ALL SOLDER TAILS Sn/Pb. TIN/LEAD
- TAIL LENGTH OPTIONS:  
E = .125 ±.010 / 3.18 ±.25  
F = .145 ±.010 / 3.68 ±.25  
H = .180 ±.010 / 4.57 ±.25
- MANUFACTURER'S NAME AND P/N, AND LOT CODE  
TO APPEAR ON THIS SURFACE PER BUS-12-108.
- FOR DOCUMENTATION MENU, SEE BUS-01-057.
- FOR PRODUCT PERFORMANCE SEE PRODUCT  
SPECIFICATION NUMBER BUS-12-090.

mat'l. code		surface		tolerance		projection		product family	
-		ISO 1302 ✓		ISO 406 ISO 1101		⊕		HPC	
ltr		ecn no dr		date		tolerances unless otherwise specified		title	
J						.xx ±.01/.3 .xxx ±.005/.13 .xxxx ±.0020/.051		3 ROW R/A RECEPTACLE CARD CONN. STYLE, S.T.B. 0 G.P.	
						angles linear		INCH/MM	
						σ±2'		scale 1:1	
				dr		M. FETROW 6/04/91		dwg no	
				enr		S. CLARK 6/04/91		sheet 2 of 2 size	
				chr		S. CLARK 6/04/91		50350 A3	
				appd		S. CLARK 6/04/91		type Product Customer Drawing	
sheet index		revision sheet							