

CAT93C46/56/66/86

1K/2K/4K/16K-Bit Serial E²PROM

FEATURES

- High Speed Operation: 1MHz
- Low Power CMOS Technology
- Wide Operating Voltage Range
 - $V_{cc} = 4.5V$ to $5.5V$
 - $V_{cc} = 2.7V$ to $6.0V$
 - $V_{cc} = 2.5V$ to $6.0V$
 - $V_{cc} = 1.8V$ to $6.0V$
- Selectable x8 or x16 Memory Organization
- Self-Timed Write Cycle with Auto-Clear
- Hardware and Software Write Protection
- Power-Up Inadvertant Write Protection
- 100,000 Program/Erase Cycles
- 100 Year Data Retention
- Commercial and Industrial Temperature Ranges

3

DESCRIPTION

The CAT93C46/56/66/86 are 1K/2K/4K/16K-bit Serial E²PROM memory devices which are configured as either registers of 16 bits (ORG pin at V_{CC}) or 8 bits (ORG pin at GND). Each register can be written (or read) serially by using the DI (or DO) pin. The CAT93C46/56/

66/86 are manufactured using Catalyst's advanced CMOS E²PROM floating gate technology. The devices are designed to endure 100,000 program/erase cycles and have a data retention of 100 years. The devices are available in 8-pin DIP or SOIC packages.

PIN CONFIGURATION

DIP Package (P)

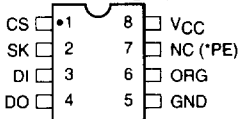

SOIC Package (J)

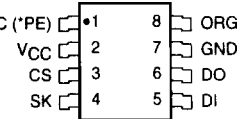

SOIC Package (S)

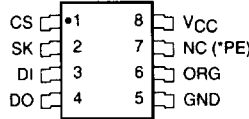

SOIC Package (K)

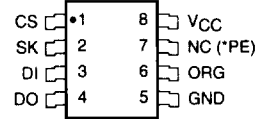

*PE (only for 93C86)

93C46/56/66 F01

PIN FUNCTIONS

Pin Name	Function
CS	Chip Select
SK	Clock Input
DI	Serial Data Input
DO	Serial Data Output
V _{CC}	+1.8 to 6.0V Power Supply
GND	Ground
ORG	Memory Organization
PE*	Program Enable
NC	No Connection

Note: When the ORG pin is connected to V_{CC}, the X16 organization is selected. When it is connected to ground, the X8 pin is selected. If the ORG pin is left unconnected, then an internal pullup device will select the X16 organization.

BLOCK DIAGRAM

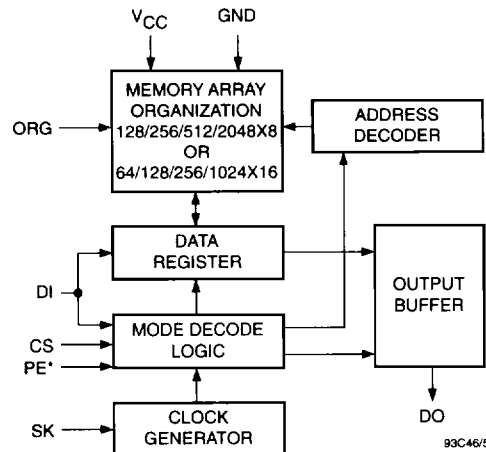

93C46/56/66 F02

ABSOLUTE MAXIMUM RATINGS*

Temperature Under Bias -55°C to +125°C
 Storage Temperature -65°C to +150°C
 Voltage on any Pin with
 Respect to Ground⁽¹⁾ -2.0V to +V_{CC} +2.0V
 V_{CC} with Respect to Ground -2.0V to +7.0V
 Package Power Dissipation
 Capability (T_a = 25°C) 1.0W
 Lead Soldering Temperature (10 secs) 300°C
 Output Short Circuit Current⁽²⁾ 100 mA

***COMMENT**

Stresses above those listed under “Absolute Maximum Ratings” may cause permanent damage to the device. These are stress ratings only, and functional operation of the device at these or any other conditions outside of those listed in the operational sections of this specification is not implied. Exposure to any absolute maximum rating for extended periods may affect device performance and reliability.

3

RELIABILITY CHARACTERISTICS

Symbol	Parameter	Min.	Max.	Units	Reference Test Method
N _{END} ⁽³⁾	Endurance	100,000		Cycles/Byte	MIL-STD-883, Test Method 1033
T _{DR} ⁽³⁾	Data Retention	100		Years	MIL-STD-883, Test Method 1008
V _{ZAP} ⁽³⁾	ESD Susceptibility	2000		Volts	MIL-STD-883, Test Method 3015
I _{LTH} ⁽³⁾⁽⁴⁾	Latch-Up	100		mA	JEDEC Standard 17

D.C. OPERATING CHARACTERISTICS

V_{CC} = +1.8V to +6.0V, unless otherwise specified.

Symbol	Parameter	Limits			Units	Test Conditions
		Min.	Typ.	Max.		
I _{CC}	Power Supply Current (Operating)			3	mA	D _I = 0.0V, f _{SK} = 1MHz V _{CC} = 5.0V, CS = 5.0V, Output Open
I _{SB}	Power Supply Current (Standby)			50	µA	CS = 0V
I _{LI}	Input Leakage Current			2	µA	V _{IN} = 0V to V _{CC}
I _{LO}	Output Leakage Current (Including ORG pin)			10	µA	V _{OUT} = 0V to V _{CC} , CS = 0V
V _{IL1} V _{IH1}	Input Low Voltage Input High Voltage	-0.1 2		0.8 V _{CC} +1	V V	4.5V ≤ V _{CC} < 5.5V
V _{IL2} V _{IH2}	Input Low Voltage Input High Voltage	0 V _{CC} X0.7		V _{CC} X0.2 V _{CC} +1	V V	1.8V ≤ V _{CC} < 2.7V
V _{OL1} V _{OH1}	Output Low Voltage Output High Voltage	2.4		0.4	V V	4.5V ≤ V _{CC} < 5.5V I _{OL} = 2.1mA I _{OH} = -400µA
V _{OL2} V _{OH2}	Output Low Voltage Output High Voltage	V _{CC} -0.2		0.2	V V	1.8V ≤ V _{CC} < 2.7V I _{OL} = 1mA I _{OH} = -100µA

Note:

- (1) The minimum DC input voltage is -0.5V. During transitions, inputs may undershoot to -2.0V for periods of less than 20 ns. Maximum DC voltage on output pins is V_{CC} +0.5V, which may overshoot to V_{CC} +2.0V for periods of less than 20 ns.
- (2) Output shorted for no more than one second. No more than one output shorted at a time.
- (3) This parameter is tested initially and after a design or process change that affects the parameter.
- (4) Latch-up protection is provided for stresses up to 100 mA on address and data pins from -1V to V_{CC} +1V.

PIN CAPACITANCE

Symbol	Test	Max.	Units	Conditions
C _{OUT} ⁽¹⁾	OUTPUT CAPACITANCE (DO)	5	pF	V _{OUT} =OV
C _{IN} ⁽¹⁾	INPUT CAPACITANCE (CS, SK, DI, ORG)	5	pF	V _{IN} =OV

Note:

(1) This parameter is tested initially and after a design or process change that affects the parameter.

INSTRUCTION SET

Instruction	Device Type	Start Bit	Opcode	Address		Data		PE ⁽¹⁾	Comments
				x8	x16	x8	x16		
READ	93C46	1	10	A6-A0	A5-A0				Read Address AN-A0
	93C56 ⁽²⁾	1	10	A8-A0	A7-A0				
	93C66	1	10	A8-A0	A7-A0				
	93C86	1	10	A10-A0	A9-A0			X	
ERASE	93C46	1	11	A6-A0	A5-A0				Clear Address AN-A0
	93C56 ⁽²⁾	1	11	A8-A0	A7-A0				
	93C66	1	11	A8-A0	A7-A0				
	93C86	1	11	A10-A0	A9-A0			1	
WRITE	93C46	1	01	A6-A0	A5-A0	D7-D0	D15-D0		Write Address AN-A0
	93C56 ⁽²⁾	1	01	A8-A0	A7-A0	D7-D0	D15-D0		
	93C66	1	01	A8-A0	A7-A0	D7-D0	D15-D0		
	93C86	1	01	A10-A0	A9-A0	D7-D0	D15-D0	1	
EWEN	93C46	1	00	11XXXXX	11XXXX				Write Enable
	93C56	1	00	11XXXXXXXX	11XXXXXXXX				
	93C66	1	00	11XXXXXXXX	11XXXXXXXX				
	93C86	1	00	11XXXXXXXXXX	11XXXXXXXXXX			X	
EWDS	93C46	1	00	00XXXXX	00XXXX				Write Disable
	93C56	1	00	00XXXXXXXX	00XXXXXXXX				
	93C66	1	00	00XXXXXXXX	00XXXXXXXX				
	93C86	1	00	00XXXXXXXXXX	00XXXXXXXXXX			X	
ERAL	93C46	1	00	10XXXXX	10XXXX				Clear All Addresses
	93C56	1	00	10XXXXXXXX	10XXXXXXXX				
	93C66	1	00	10XXXXXXXX	10XXXXXXXX				
	93C86	1	00	10XXXXXXXXXX	10XXXXXXXXXX			1	
WRAL	93C46	1	00	01XXXXX	01XXXX	D7-D0	D15-D0		Write All Addresses
	93C56	1	00	01XXXXXXXX	01XXXXXXXX	D7-D0	D15-D0		
	93C66	1	00	01XXXXXXXX	01XXXXXXXX	D7-D0	D15-D0		
	93C86	1	00	01XXXXXXXXXX	01XXXXXXXXXX	D7-D0	D15-D0	1	

Note:

(1) Only applicable to 93C86

(2) Address bit A8 for 256x8 ORG and A7 for 128x16 ORG are "Don't Care" bits, but must be kept at either a "1" or "0" for READ, WRITE and ERASE commands.

3

A.C. CHARACTERISTICS

SYMBOL	PARAMETER	Limits						UNITS	Test Conditions
		V _{CC} = 1.8V-6V*		V _{CC} = 2.7V -6V V _{CC} = 2.5V-6V		V _{CC} = 4.5V-5.5V			
		Min.	Max.	Min.	Max.	Min.	Max.		
t _{CSS}	CS Setup Time	200		100		50		ns	C _L = 100pF
t _{CSH}	CS Hold Time	0		0		0		ns	
t _{DIS}	DI Setup Time	400		200		100		ns	
t _{DIH}	DI Hold Time	400		200		100		ns	
t _{PD1}	Output Delay to 1		1		0.5		0.25	μs	
t _{PD0}	Output Delay to 0		1		0.5		0.25	μs	
t _{HZ} ⁽¹⁾	Output Delay to High-Z		400		200		100	ns	
t _{EW}	Program/Erase Pulse Width		10		10		10	ms	
t _{CSSMIN}	Minimum CS Low Time	1		0.5		0.25		μs	
t _{SKHI}	Minimum SK High Time	1		0.5		0.25		μs	
t _{SKLOW}	Minimum SK Low Time	1		0.5		0.25		μs	
t _{SV}	Output Delay to Status Valid		1		0.5		0.25	μs	
SK _{MAX}	Maximum Clock Frequency	DC	250	DC	500	DC	1000	KHZ	

* Preliminary data for 93C56/66/86.

NOTE:

(1) This parameter is tested initially and after a design or process change that affects the parameter.

DEVICE OPERATION

The CAT93C46/56/66/86 is a 1024/2048/4096/16384-bit nonvolatile memory intended for use with industry standard microprocessors. The CAT93C46/56/66/86 can be organized as either registers of 16 bits or 8 bits. When organized as X16, seven 9-bit instructions for 93C46; seven 11-bit instructions for 93C56 and 93C66; seven 13-bit instructions for 93C86, control the reading, writing and erase operations of the device. When organized as X8, seven 10-bit instructions for 93C46; seven 12-bit instructions for 93C56 and 93C66; seven 14-bit instructions for 93C86, control the reading, writing and erase operations of the device. The CAT93C46/56/66/86 operates on a single 1.8V supply and will generate on chip, the high voltage required during any write operation.

Instructions, addresses, and write data are clocked into the DI pin on the rising edge of the clock (SK). The DO

pin is normally in a high impedance state except when reading data from the device, or when checking the ready/busy status after a write operation.

The ready/busy status can be determined after the start of a write operation by selecting the device (CS high) and polling the DO pin; DO low indicates that the write operation is not completed, while DO high indicates that the device is ready for the next instruction. If necessary, the DO pin may be placed back into a high impedance state during chip select by shifting a dummy "1" into the DI pin. The DO pin will enter the high impedance state on the falling edge of the clock (SK). Placing the DO pin into the high impedance state is recommended in applications where the DI pin and the DO pin are to be tied together to form a common DI/O pin.

3

Figure 1. Synchronous Data Timing

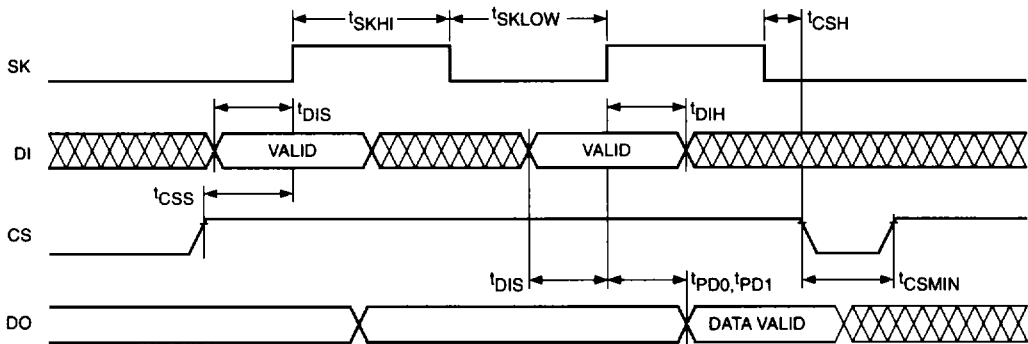

5040 FHD F03

Figure 2. Read Instruction Timing

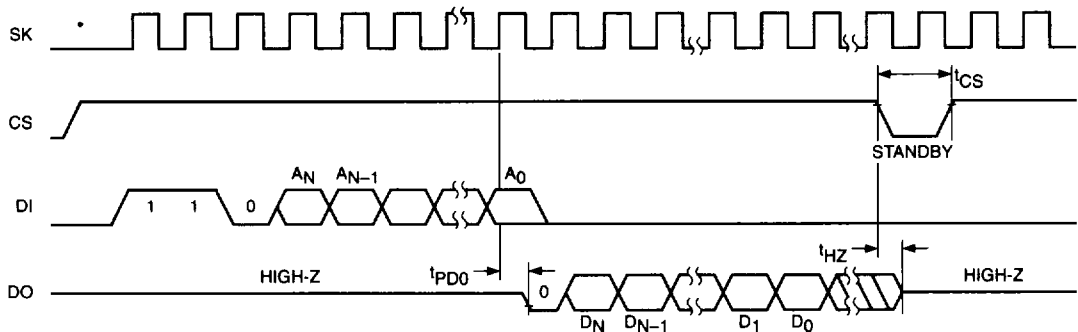

5040 FHD F04

The format for all instructions sent to the device is a logical "1" start bit, a 2-bit (or 4-bit) opcode, 6-bit (93C46)/ 8-bit (93C56 or 93C66)/10-bit (93C86) (an additional bit when organized X8) and for write operations a 16-bit data field (8-bit for X8 organizations).

Read

Upon receiving a READ command and an address (clocked into the DI pin), the DO pin of the CAT93C46/56/66/86 will come out of the high impedance state and, after sending an initial dummy zero bit, will begin shifting out the data addressed (MSB first). The output data bits will toggle on the rising edge of the SK clock and are stable after the specified time delay (t_{PD0} or t_{PD1}).

Write

After receiving a WRITE command, address and the data, the CS (Chip Select) pin must be deselected for a minimum of 250ns (t_{CSMIN}). The falling edge of CS will start the self clocking clear and data store cycle of the

memory location specified in the instruction. The clocking of the SK pin is not necessary after the device has entered the self clocking mode. The ready/busy status of the CAT93C46/56/66/86 can be determined by selecting the device and polling the DO pin. Since this device features Auto-Clear before write, it is NOT necessary to erase a memory location before it is written into.

Erase

Upon receiving an ERASE command and address, the CS (Chip Select) pin must be deselected for a minimum of 250ns (t_{CSMIN}). The falling edge of CS will start the self clocking clear cycle of the selected memory location. The clocking of the SK pin is not necessary after the device has entered the self clocking mode. The ready/busy status of the CAT93C46/56/66/86 can be determined by selecting the device and polling the DO pin. Once cleared, the content of a cleared location returns to a logical "1" state.

Figure 3. Write Instruction Timing

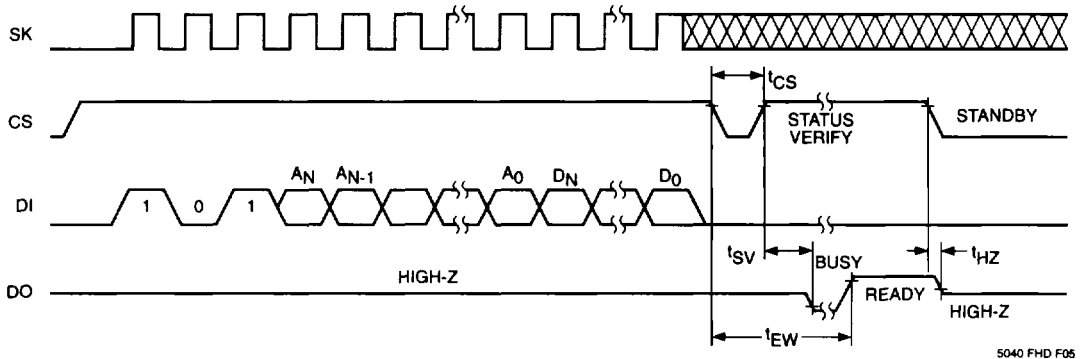

5040 FHD F06

Figure 4. Erase Instruction Timing

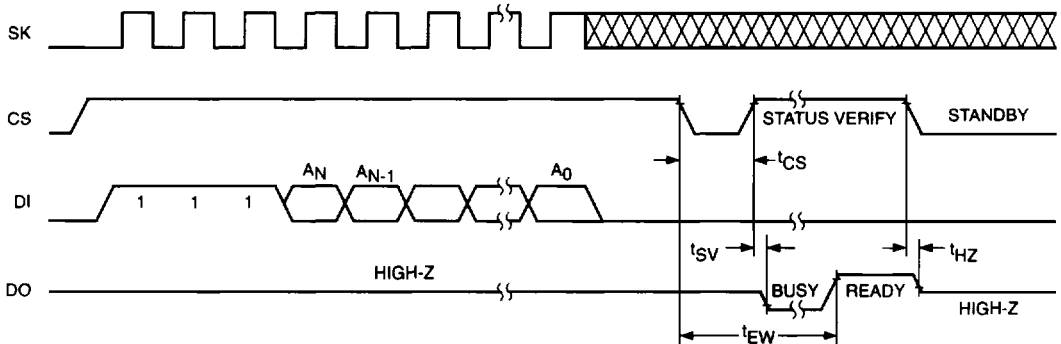

5040 FHD F07

Erase/Write Enable and Disable

The CAT93C46/56/66/86 powers up in the write disable state. Any writing after power-up or after an EWDS (write disable) instruction must first be preceded by the EWEN (write enable) instruction. Once the write instruction is enabled, it will remain enabled until power to the device is removed, or the EWDS instruction is sent. The EWDS instruction can be used to disable all CAT93C46/56/66/86 write and clear instructions, and will prevent any accidental writing or clearing of the device. Data can be read normally from the device regardless of the write enable/disable status.

Erase All

Upon receiving an ERAL command, the CS (Chip Select) pin must be deselected for a minimum of 250ns (t_{CSMIN}). The falling edge of CS will start the self clocking clear cycle of all memory locations in the device. The clocking of the SK pin is not necessary after the device has entered the self clocking mode. The ready/busy status of the CAT93C46/56/66/86 can be determined by

selecting the device and polling the DO pin. Once cleared, the contents of all memory bits return to a logical "1" state.

Write All

Upon receiving a WRAL command and data, the CS (Chip Select) pin must be deselected for a minimum of 250ns (t_{CSMIN}). The falling edge of CS will start the self clocking data write to all memory locations in the device. The clocking of the SK pin is not necessary after the device has entered the self clocking mode. The ready/busy status of the CAT93C46/56/66/86 can be determined by selecting the device and polling the DO pin. It is not necessary for all memory locations to be cleared before the WRAL command is executed.

Note: This note is applicable only to 93C86. The write, erase, write all and, erase all instruction requires PE=1 for 93C86. If PE is left floating, 93C86 is in program enabled mode.

3

Figure 5. EWEN/EWDS Instruction Timing

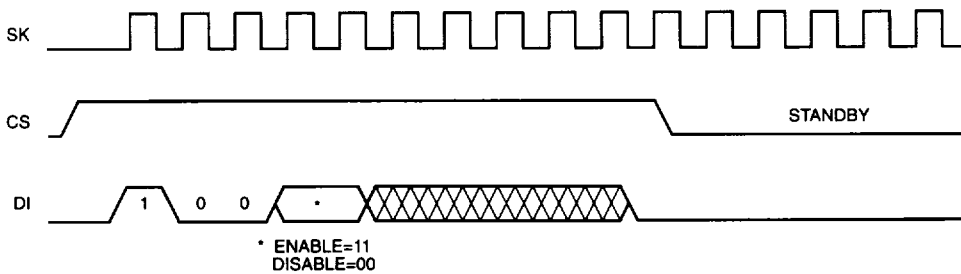

93C46/56/66 F07

Figure 6. ERAL Instruction Timing

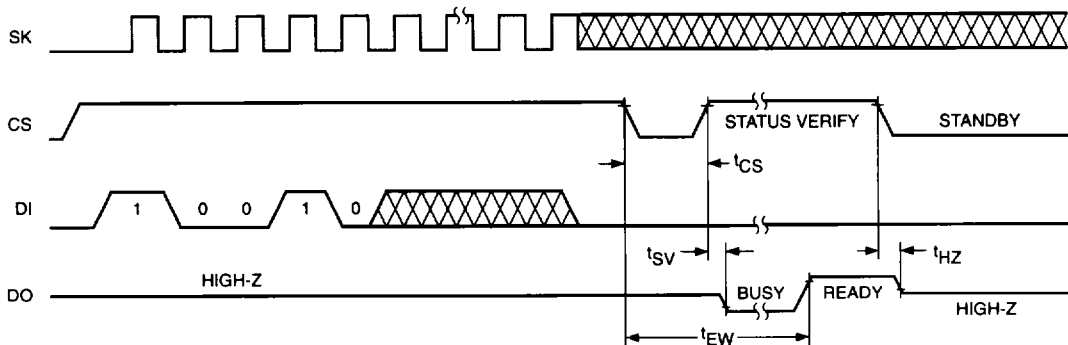

5040 FHD F06

Figure 7. WRAL Instruction Timing

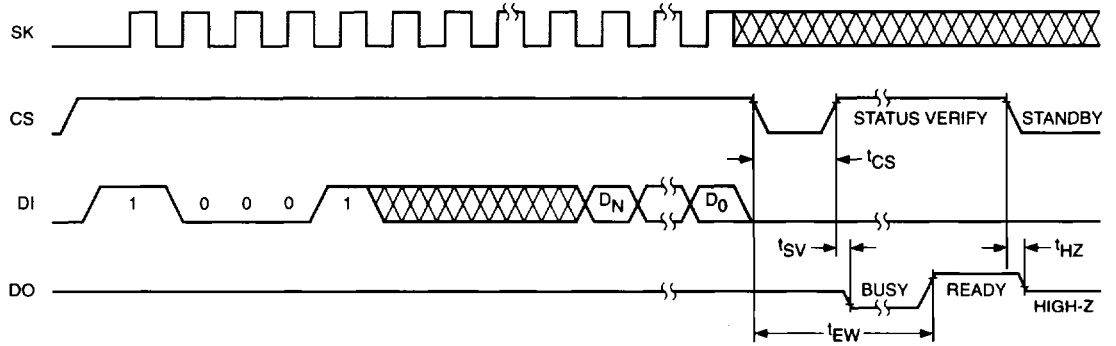

93C46/56/66 F09

ORDERING INFORMATION

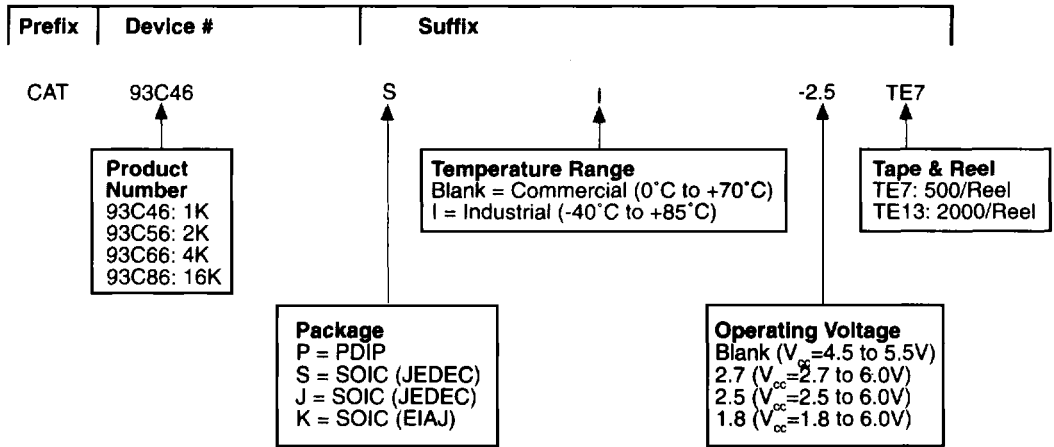

93C46/56/66 F10

Notes:

(1) The device used in the above example is a 93C46SI-2.5TE7 (SOIC, Industrial Temperature, 2.5 Volt to 6 Volt Operating Voltage, Tape & Reel)