

Features

- Low-drop voltage
- Very low quiescent current
- Low starting current consumption
- Integrated temperature protection
- Protection against reverse polarity
- Input voltage up to 42 V
- Overvoltage protection up to 65 V (≤ 400 ms)
- Short-circuit proof
- Suited for automotive electronics
- Wide temperature range
- EMC proofed (100 V/m)

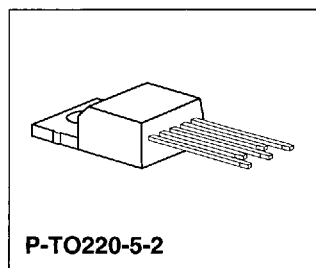
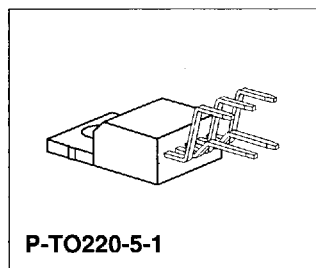

Type	Ordering Code	Package
▼ TLE 4260	Q67000-A8187	P-TO220-5-1
▼ TLE 4260 S	Q67000-A9044	P-TO220-5-2

▼ Please also refer to the new pin compatible device TLE 4270

Functional Description

TLE 4260; S is a 5-V low-drop fixed-voltage regulator in a P-TO220-5-H/S package. The maximum input voltage is 42 V (65 V/ ≤ 400 ms). The device can produce an output current of more than 500 mA. It is shortcircuit-proof and incorporates temperature protection that disables the circuit at unpermissibly high temperatures.

Due to the wide temperature range of -40 to 150 °C, the TLE 4260; S is also suitable for use in automotive applications.

The IC regulates an input voltage V_I in the range $6 < V_I < 35$ V to $V_{Qnominal} = 5.0$ V. A reset signal is generated for an output voltage of $V_O < 4.75$ V. The reset delay can be set externally with a capacitor. If the output current is reduced below 10 mA, the regulator switches internally to standby and the reset generator is turned off. The standby current drops to max. 700 μ A.

■ 8235605 0118571 3T3 ■

Pin Configuration

(top view)

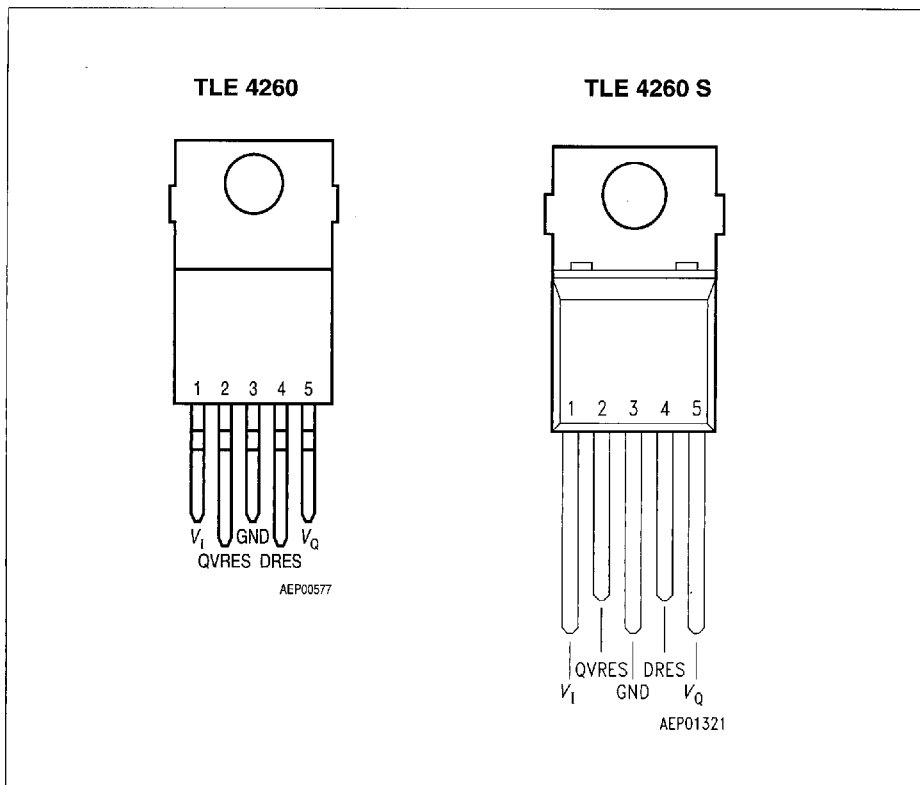

Pin Definitions and Functions (TLE 4260 and TLE 4260 S)

Pin No.	Symbol	Function
1	V_I	Input ; block directly to ground at the IC by a 470-nF capacitor
2	QVRES	Reset output ; open collector output controlled by the reset delay
3	GND	Ground
4	DRES	Reset delay ; wired to ground with a capacitor
5	V_Q	5-V output voltage ; block to ground with a 22- μ F capacitor

■ 8235605 0118572 23T ■

Circuit Description

The control amplifier compares a reference voltage, which is kept highly accurate by resistance adjustment, to a voltage that is proportional to the output voltage and drives the base of the series transistor via a buffer. Saturation control as a function of the load current prevents any over-saturation of the power element. If the output voltage goes below 96% of its typical value, an external capacitor is discharged on pin 4 by the reset generator. If the voltage on the capacitor reaches the lower threshold V_{ST} , a reset signal is issued on pin 2 and not cancelled again until the upper threshold V_{DT} is exceeded. For an output current of less than $I_{QN\ Off} = 10\text{ mA}$ the standby changeover turns off the reset generator. The latter is turned on again when the output current increases, the output voltage drops below 4.2 V or the delay capacitor is discharged by external measures.

The IC also incorporates a number of internal circuits for protection against:

- Overload
- Overvoltage
- Overtemperature
- Reverse polarity

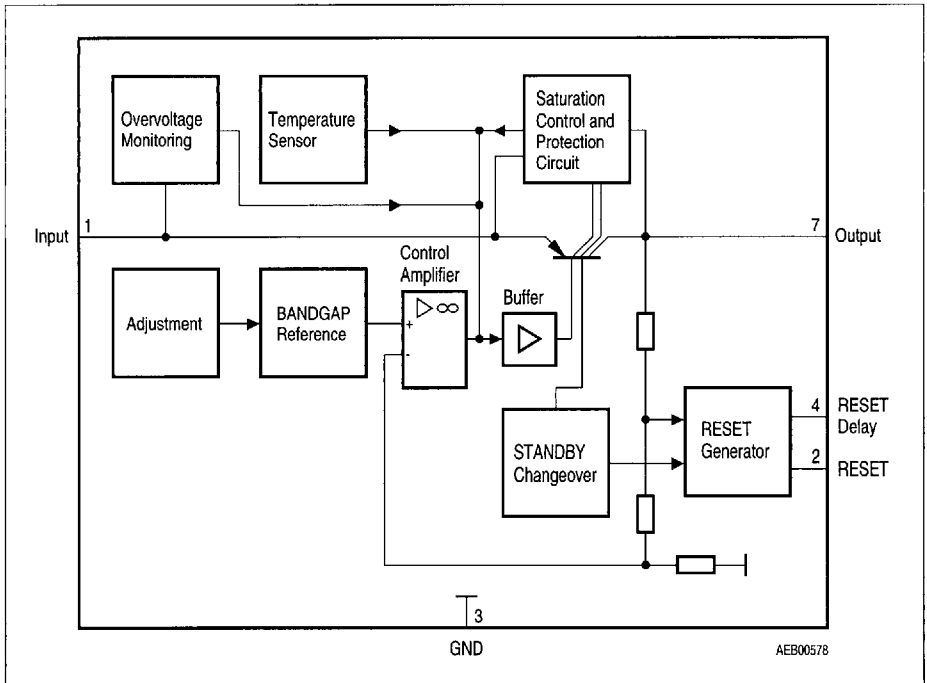

Block Diagram

■ 8235605 0118573 176 ■

Absolute Maximum Ratings

Parameter	Symbol	Limit Values		Unit	Remarks
		min.	max.		

Input (Pin 1)

Input voltage	V_I	- 42	42	V	-
	V_I	-	65	V	$t \leq 400$ ms
Input current	I_I	-	1.6	A	-

Reset Output (Pin 2)

Voltage	V_R	- 0.3	42	V	-
Current	I_R	-	-	-	internally limited

Ground (Pin 3)

Current	I_{GND}	- 0.5	-	A	-
---------	-----------	-------	---	---	---

Reset Delay (Pin 4)

Voltage	V_D	- 0.3	42	V	-
Current	I_D	-	-	-	internally limited

Output (Pin 5)

Differential voltage	$V_I - V_Q$	- 5.25	V_I	V	-
Current	I_Q	-	1.4	A	-

Temperature

Junction temperature	T_j	-	32	°C	-
Storage temperature	T_{stg}	- 50	150	°C	-

■ 8235605 0118574 002 ■

Operating Range

Parameter	Symbol	Limit Values		Unit	Remarks
		min.	max.		
Input voltage	V_I	–	32	V	1)
Junction temperature	T_j	– 40	165	°C	–

Thermal Resistances

Junction ambient	R_{thja}	–	65	K/W	–
Junction case	R_{thjc}	–	3	K/W	–

1) See diagram "Output Current versus Input Voltage"

■ 8235605 0118575 T49 ■

Characteristics

$V_I = 13.5 \text{ V}$; $T_j = 25 \text{ }^\circ\text{C}$; (unless otherwise specified)

Parameter	Symbol	Limit Values			Unit	Test Condition
		min.	typ.	max.		

Normal Operation

Output voltage	V_Q	4.75	5.0	5.25	V	$25 \text{ mA} \leq I_Q \leq 500 \text{ mA}$ $6 \text{ V} \leq V_I \leq 28 \text{ V}$ $-40 \text{ }^\circ\text{C} \leq T_j \leq 125 \text{ }^\circ\text{C}$
Short-circuit current	I_{SC}	500	1000	–	mA	$V_I = 17 \text{ V}$ to 28 V ; $V_Q = 0 \text{ V}$
Current consumption $I_q = I_I - I_Q$	I_q	–	8.5	10	mA ¹⁾	$6 \text{ V} \leq V_I \leq 28 \text{ V}$ $I_Q = 150 \text{ mA}$
Current consumption $I_q = I_I - I_Q$	I_q	–	50	65	mA ¹⁾	$6 \text{ V} \leq V_I \leq 28 \text{ V}$ $I_Q = 500 \text{ mA}$
Current consumption $I_q = I_I - I_Q$	I_q	–	–	80	mA ¹⁾	$V_I \leq 6 \text{ V}$ $I_Q = 500 \text{ mA}$
Drop voltage	V_{DR}	–	0.35	0.5	V	$V_I = 4.5 \text{ V}$; $I_Q = 0.5 \text{ A}$
Drop voltage	V_{DR}	–	0.2	0.3	V	$V_I = 4.5 \text{ V}$; $I_Q = 0.15 \text{ A}$
Load regulation	ΔV_Q	–	15	35	mV	$25 \text{ mA} \leq I_Q \leq 500 \text{ mA}$
Supply-voltage regulation	ΔV_Q	–	15	50	mV	$V_I \leq 6 \text{ V}$ to 28 V ; $I_Q = 100 \text{ mA}$
Supply-voltage regulation	ΔV_Q	–	5	25	mV	$V_I \leq 6 \text{ V}$ to 16 V ; $I_Q = 100 \text{ mA}$
Ripple rejection	SVR	–	54	–	dB	$f = 100 \text{ Hz}$; $V_r = 0.5 \text{ V}_{pp}$
Temperature drift of output voltage ¹⁾	α_{VQ}	–	2×10^{-4}	–	1/ $^\circ\text{C}$	–

Standby Operation

Quiescent current; $I_q = I_I - I_Q$	I_q	–	500	700	μA	$10 \text{ V} \leq V_I \leq 16 \text{ V}$; $I_Q = 0 \text{ mA}$
Quiescent current; $I_q = I_I - I_Q$	I_q	–	750	850	μA	$10 \text{ V} \leq V_I \leq 16 \text{ V}$; $I_Q = 5 \text{ mA}$

■ 8235605 0118576 985 ■

Characteristics (cont'd)

$V_I = 13.5 \text{ V}$; $T_j = 25 \text{ }^\circ\text{C}$; (unless otherwise specified)

Parameter	Symbol	Limit Values			Unit	Test Condition
		min.	typ.	max.		

Standby Off/Normal On

Current consumption	I_{QSOFF}	–	1.0	1.2	mA	see test diagram
Current consumption	I_{QNON}	–	1.7	2.2	mA	see test diagram

Normal Off/Standby On

Current consumption	I_{QNOFF}	–	1.55	2.00	mA	see test diagram
Current consumption	I_{QSON}	–	850	1050	μA	see test diagram
Switching threshold	I_{QNOFF}	7.5	10	12.5	mA	see test diagram
Switching hysteresis	ΔI_Q	2.25	3	4	mA	see test diagram

Reset Generator

Switching threshold	V_{RT}	94	96	97	%	in % of V_Q ; $I_Q > 500 \text{ mA}$; $V_I = 6 \text{ V}$
Saturation voltage	V_R	–	0.25	0.40	V	$I_R = 3 \text{ mA}$; $V_I = 4.5 \text{ V}$
Reverse current	I_R	–	–	1	μA	$V_R = 5 \text{ V}$
Charge current	I_D	7	10	13	μA	–
Switching threshold	V_{ST}	0.9	1.1	1.3	V	–
Delay switching threshold	V_{DT}	2.15	2.50	2.75	V	–
Delay time	t_D	–	25	–	ms	$C_D = 100 \text{ nF}$
Delay time	t_t	–	5	–	μs	$C_D = 100 \text{ nF}$

General Data

Turn-Off voltage	V_{IOFF}	40	43	45	V	$I_Q < 1 \text{ mA}$
Turn-Off hysteresis	ΔV_I	–	3.0	–	V	–
Leakage current	I_{QS}	–	500	–	μA	$V_Q = 0 \text{ V}$; $V_I = 45 \text{ V}$
Reverse output current	I_{QR}	–	–	1.5	mA	$V_Q = 5 \text{ V}$; $V_I = \text{open}$

¹⁾ See diagram

8235605 0118577 811

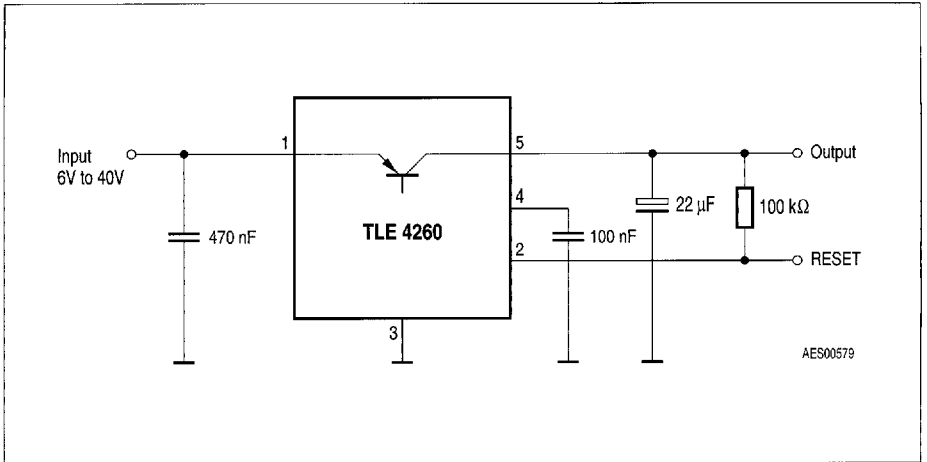

Application Circuit

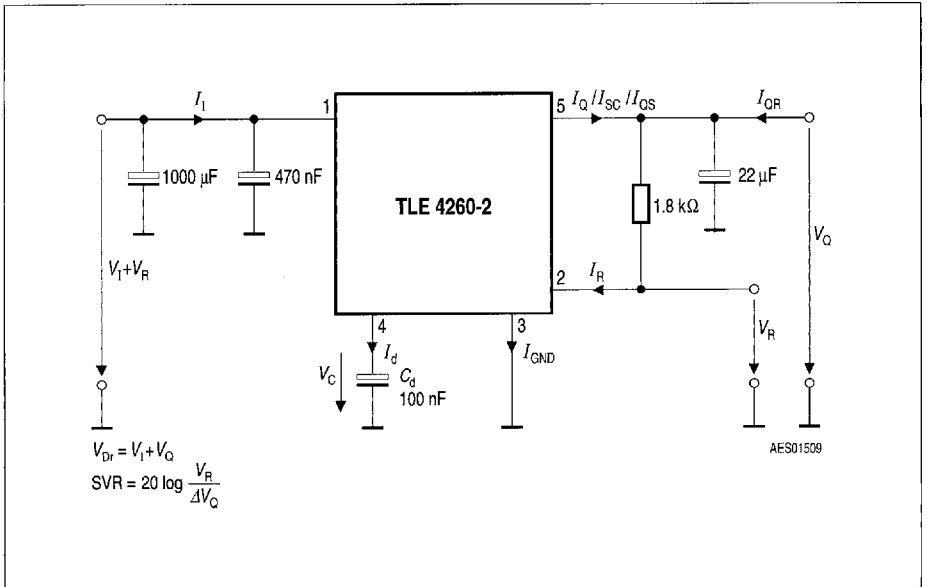

Test Circuit

8235605 0118578 758

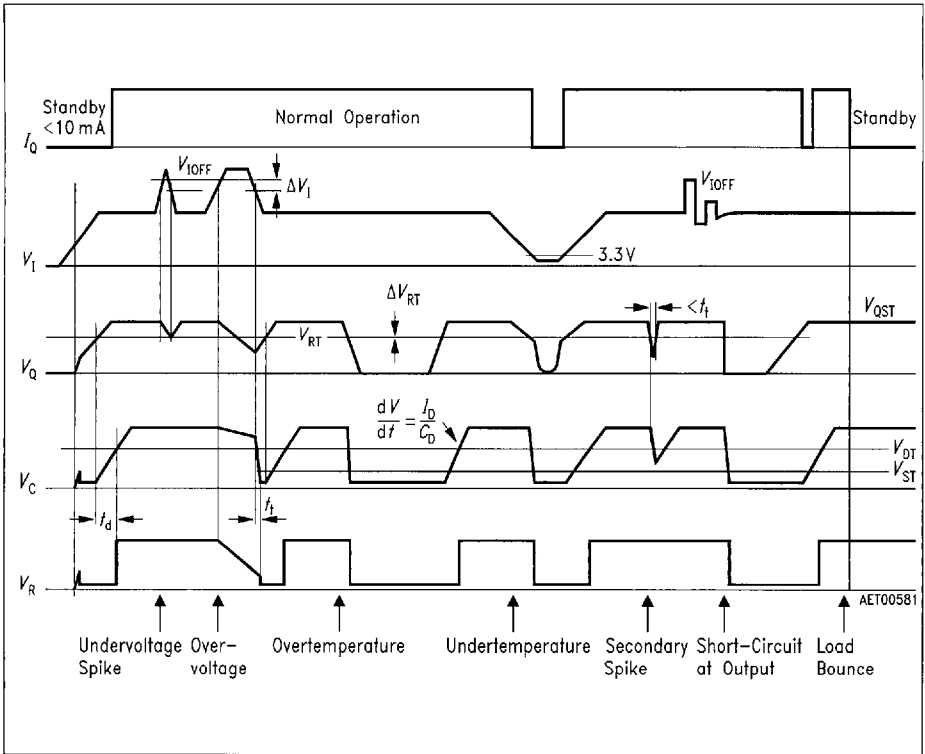

Time Response

8235605 0118579 694

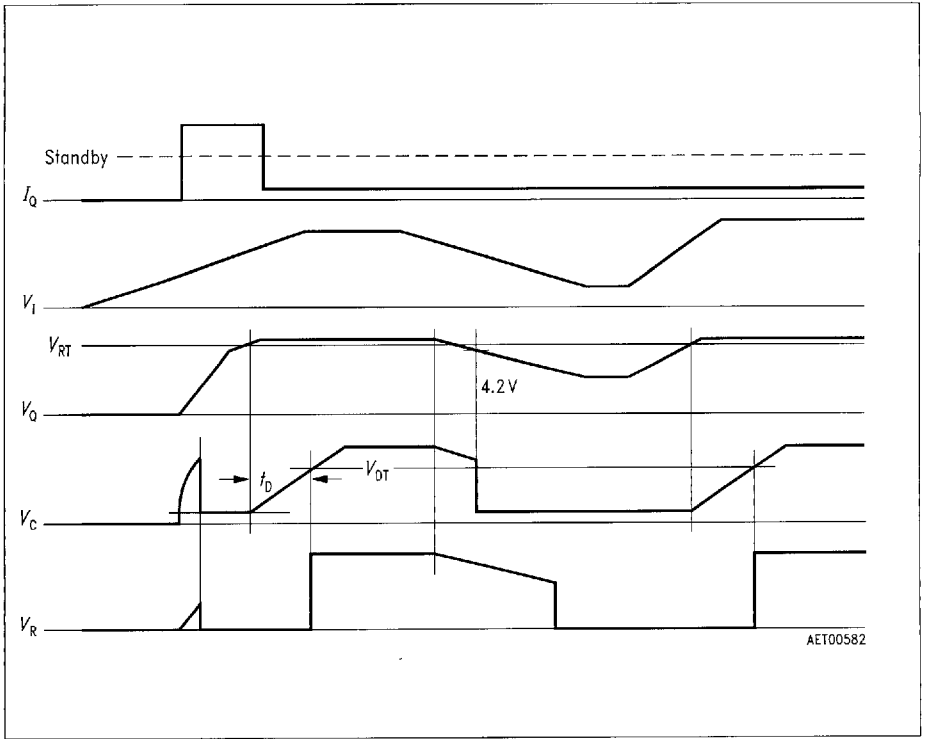

Time Responce in Standby Condition

8235605 0118580 306

Standby/Normal Changeover

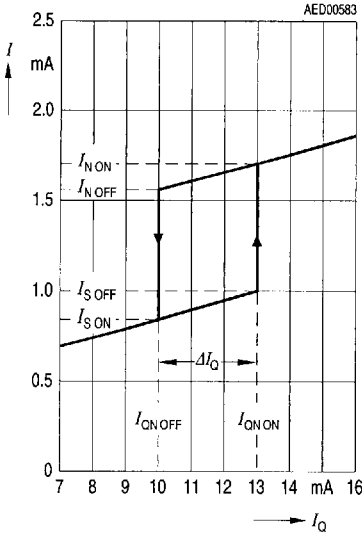

Output Voltage versus Temperature

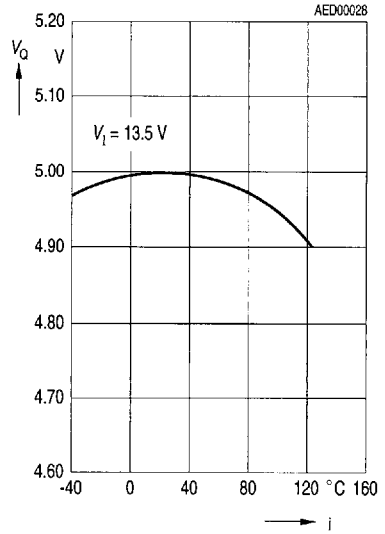

Drop Voltage versus Output Current

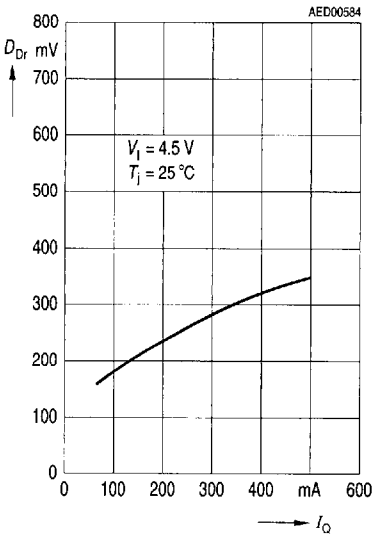

Current Consumption versus Output Current

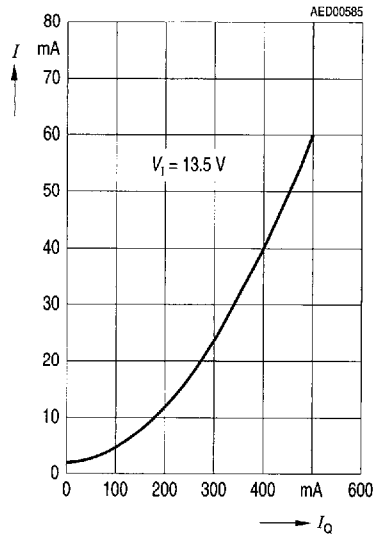

Current Consumption versus Input Voltage

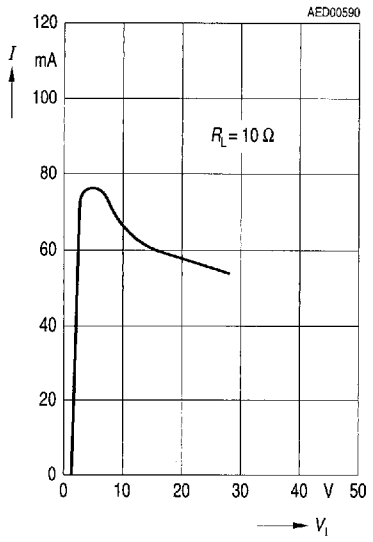

Output Voltage versus Input Voltage

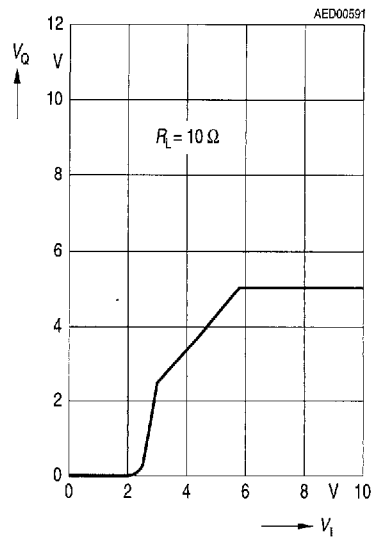

Output Current versus Input Voltage

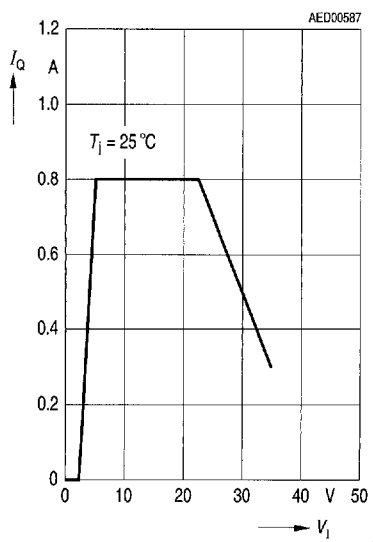

8235605 0118582 189

Package Outlines

P-TO220-5-1

(Plastic Transistor Single Outline)

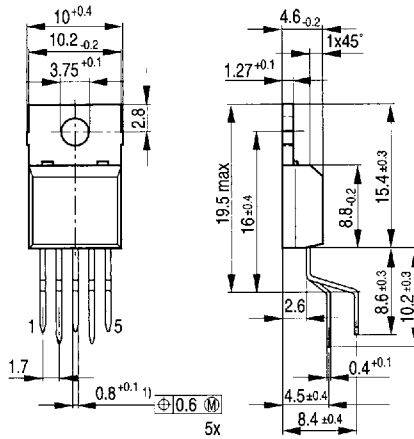

- 1) $1_{-0.15}$ at dam bar (max 1.8 from body)
- 1) $1_{-0.15}$ im Dichtstegbereich (max 1.8 vom Körper)

Weighth approx. 2.1 g

GPT05107

Sorts of Packing

Package outlines for tubes, trays etc. are contained in our Data Book "Package Information".

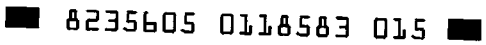

Dimensions in mm

P-TO220-5-1

(Plastic Transistor Single Outline)

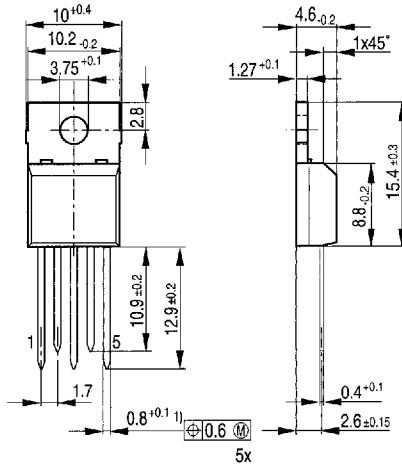

- 1) $1_{-0.15}$ at dam bar (max 1.8 from body)
- 1) $1_{-0.15}$ im Dichtstegbereich (max 1.8 vom Körper)

Weigth approx. 2.1 g

GPT05256

■ 8235605 0118584 751 ■

Sorts of Packing

Package outlines for tubes, trays etc. are contained in our Data Book "Package Information".

Dimensions in mm