

TOSHIBA LED LAMP

**TLG133AP, TLG134AP, TLO133AP, TLO134AP, TLPG133AP  
 TLPG134AP, TLR133AP, TLR134AP, TLS133AP, TLS134AP  
 TLR133AP, TLR134AP, TLY133AP, TLY134AP**

PANEL CIRCUIT INDICATOR

Unit in mm

- All Plastic Mold Type  
 TL□ 133AP : Colored Transparent Lens  
 TL□ 134AP : Colored Diffused Lens
- High Intensity & Moderate Radiation Angle  
 Half Angle = ±15 deg. (Typ.) (Limits for 50% of I<sub>f</sub>)  
 Recommended Forward Current : I<sub>f</sub> = 15~20mA (DC)
- Fast Response Time, Capable of Pulse Operation.
- Without stand-offs

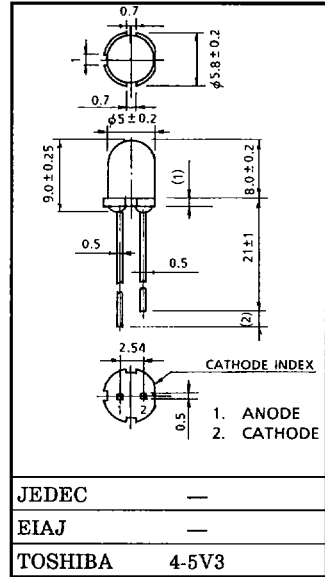

Weight : 0.33g

MATERIALS

PRODUCT NAME	MATERIALS	LIGHT EMITTING COLOR
TLPG133AP/TLPG134AP	GaP	Pure Green
TLG133AP/TLG134AP	GaP	Green
TLY133AP/TLY134AP	GaAsP	Yellow
TLO133AP/TLO134AP	GaAsP	Orange
TLS133AP/TLS134AP	GaAsP	Red
TLUR133AP/TLUR134AP	GaAlAs	
TLR133AP/TLR134AP	GaP	

MAXIMUM RATINGS (Ta = 25°C)

PRODUCT NAME	FORWARD CURRENT I <sub>f</sub> (mA)	REVERSE VOLTAGE V <sub>R</sub> (V)	POWER DISSIPATION P <sub>D</sub> (mW)	OPERATING TEMPERATURE RANGE T <sub>opr</sub> (°C)	STORAGE TEMPERATURE RANGE T <sub>stg</sub> (°C)
TLPG133AP/TLPG134AP	25	4	70	-20~75	-30~100
TLG133AP/TLG134AP	25	4	70	-20~75	-30~100
TLY133AP/TLY134AP	25	4	70	-20~75	-30~100
TLO133AP/TLO134AP	25	4	70	-20~75	-30~100
TLS133AP/TLS134AP	25	4	70	-20~75	-30~100
TLUR133AP/TLUR134AP	25	4	55	-20~75	-30~100
TLR133AP/TLR134AP	25	4	70	-20~75	-30~100

961001EAC1

- TOSHIBA is continually working to improve the quality and the reliability of its products. Nevertheless, semiconductor devices in general can malfunction or fail due to their inherent electrical sensitivity and vulnerability to physical stress. It is the responsibility of the buyer, when utilizing TOSHIBA products, to observe standards of safety, and to avoid situations in which a malfunction or failure of a TOSHIBA product could cause loss of human life, bodily injury or damage to property. In developing your designs, please ensure that TOSHIBA products are used within specified operating ranges as set forth in the most recent products specifications. Also, please keep in mind the precautions and conditions set forth in the TOSHIBA Semiconductor Reliability Handbook.
- Gallium arsenide (GaAs) is a substance used in the products described in this document. GaAs dust and fumes are toxic. Do not break, cut or pulverize the product, or use chemicals to dissolve them. When disposing of the products, follow the appropriate regulations. Do not dispose of the products with other industrial waste or with domestic garbage.
- The information contained herein is presented only as a guide for the applications of our products. No responsibility is assumed by TOSHIBA CORPORATION for any infringements of intellectual property or other rights of the third parties which may result from its use. No license is granted by implication or otherwise under any intellectual property or other rights of TOSHIBA CORPORATION or others.
- The information contained herein is subject to change without notice.

ELECTRO-OPTICAL CHARACTERISTICS (Ta = 25°C)  
133AP SERIES (Colored transparent lens)

PRODUCT NAME	EMISSION SPECTRUM			LUMINOUS INTENSITY I <sub>V</sub>			FORWARD VOLTAGE V <sub>F</sub>			REVERSE CURRENT I <sub>R</sub>	
	λ <sub>p</sub>	Δλ	I <sub>F</sub>	MIN.	TYP.	I <sub>F</sub>	TYP.	MAX.	I <sub>F</sub>	MAX.	V <sub>R</sub>
TLPG133AP	555	20	15	8.0	25	15	2.15	2.8	20	100	4
TLG133AP	565	25	15	17	80	15	2.15	2.8	20	100	4
TLY133AP	585	32	15	10	50	15	2.05	2.8	20	100	4
TLO133AP	610	35	15	10	35	15	2.05	2.8	20	100	4
TLS133AP	635	40	15	10	35	15	2.05	2.8	20	100	4
TLUR133AP	660	25	20	17	40	20	1.75	2.2	20	100	4
TLR133AP	700	100	15	5.0	15	15	2.15	2.8	20	100	4
Unit	nm		mA	mcd		mA	V		mA	μA	V

134AP SERIES (Colored lusterless lens)

PRODUCT NAME	EMISSION SPECTRUM			LUMINOUS INTENSITY I <sub>V</sub>			FORWARD VOLTAGE V <sub>F</sub>			REVERSE CURRENT I <sub>R</sub>	
	λ <sub>p</sub>	Δλ	I <sub>F</sub>	MIN.	TYP.	I <sub>F</sub>	TYP.	MAX.	I <sub>F</sub>	MAX.	V <sub>R</sub>
TLPG134AP	555	20	15	4.0	15	15	2.15	2.8	20	100	4
TLG134AP	565	25	15	6.0	30	15	2.15	2.8	20	100	4
TLY134AP	585	32	15	5.0	20	15	2.05	2.8	20	100	4
TLO134AP	610	35	15	4.0	15	15	2.05	2.8	20	100	4
TLS134AP	635	40	15	4.0	15	15	2.05	2.8	20	100	4
TLUR134AP	660	25	20	7.0	20	20	1.75	2.2	20	100	4
TLR134AP	700	100	15	2.0	6.0	15	2.15	2.8	20	100	4
Unit	nm		mA	mcd		mA	V		mA	μA	V

PRECAUTION

Please be Careful of the followings.

- Soldering temperature : 260°C MAX. Soldering time : 3s MAX.  
(Soldering portion of lead : up to 2mm from the body of the device)
- If the lead is formed, the lead should be formed up to 5mm from the body of the device without forming stress to the resin. Soldering should be performed after lead forming.

$I_v - I_F$

