

# FEMTOCLOCKS™ CRYSTAL-TO-LVCMOS/LVTTL FREQUENCY SYNTHESIZER

**ICS840004-01**

## GENERAL DESCRIPTION



The ICS840004-01 is a 4 output LVCMOS/LVTTL Synthesizer optimized to generate Ethernet reference clock frequencies and is a member of the HiPerClocks™ family of high performance clock solutions from ICS. Using a 25MHz, 18pF parallel resonant crystal, the following frequencies can be generated based on the 2 frequency select pins (F\_SEL1:0): 156.25MHz, 125MHz, and 62.5MHz. The ICS840004-01 uses ICS' 3<sup>rd</sup> generation low phase noise VCO technology and can achieve 1ps or lower typical random rms phase jitter, easily meeting Ethernet jitter requirements. The ICS840004-01 is packaged in a small 20-pin TSSOP package.

## FEATURES

- Four LVCMOS/LVTTL outputs, 17Ω typical output impedance
  - Selectable crystal oscillator interface or LVCMOS/LVTTL single-ended input
  - Output frequency Range: 56MHz - 175MHz
  - VCO Range: 560MHz - 700MHz
  - RMS phase jitter at 156.25MHz (1.875MHz - 20MHz): 0.52ps (typical) design target
- Phase noise:
- | Offset | Noise Power   |
|--------|---------------|
| 100Hz  | -94.9 dBc/Hz  |
| 1kHz   | -119.6 dBc/Hz |
| 10kHz  | -128.9 dBc/Hz |
| 100kHz | -129.2 dBc/Hz |
- Full 3.3V or 3.3V core/2.5V output supply mode
  - 0°C to 70°C ambient operating temperature
  - Available in both standard and lead-free RoHS-compliant packages

**FREQUENCY SELECT FUNCTION TABLE FOR ETHERNET FREQUENCIES**

Inputs					Output Frequency (MHz) (25MHz Ref.)
F_SEL1	F_SEL0	M Divider Value	N Divider Value	M/N Ratio Value	
0	0	25	4	6.25	156.25
0	1	25	5	5	125
1	0	25	10	2.5	62.5
1	1	25	5	5	125 (default)

## BLOCK DIAGRAM

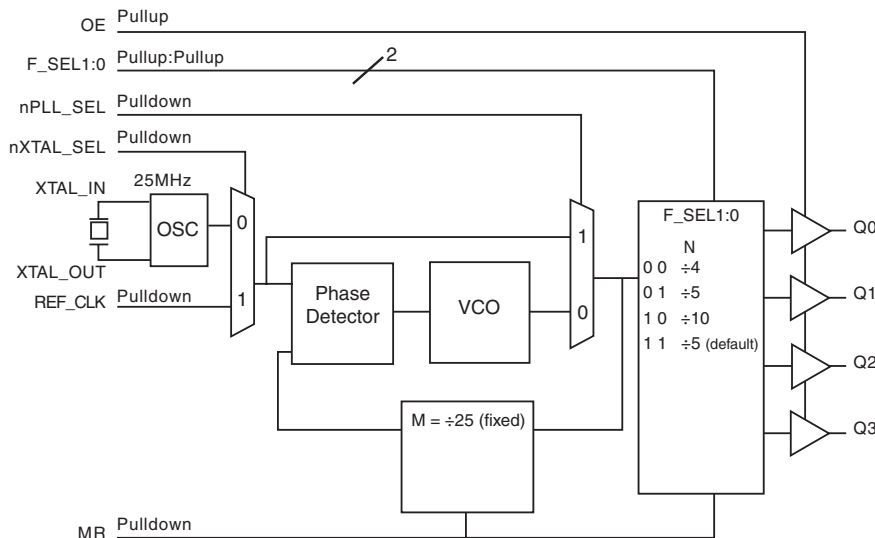

## PIN ASSIGNMENT

F_SEL0	1	20	F_SEL1
nc	2	19	GND
nXTAL_SEL	3	18	Q0
REF_CLK	4	17	Q1
OE	5	16	V <sub>DD0</sub>
MR	6	15	Q2
nPLL_SEL	7	14	Q3
V <sub>DDA</sub>	8	13	GND
nc	9	12	XTAL_IN
V <sub>DD</sub>	10	11	XTAL_OUT

### ICS840004-01 20-Lead TSSOP

6.5mm x 4.4mm x 0.92mm  
package body  
**G Package**  
Top View

TABLE 1. PIN DESCRIPTIONS

Number	Name	Type		Description
1, 20	F_SELO, F_SEL1	Input	Pullup	Frequency select pin. LVCMOS/LVTTL interface levels.
2, 9	nc	Unused		No connect.
3	nXTAL_SEL	Input	Pulldown	Selects between the crystal or REF_CLK inputs as the PLL reference source. When HIGH, selects REF_CLK. When LOW, selects XTAL inputs. LVCMOS/LVTTL interface levels.
4	REF_CLK	Input	Pulldown	Single-ended LVCMOS/LVTTL reference clock input.
5	OE	Input	Pullup	Output enable pin. When HIGH, the outputs are active. When LOW, the outputs are in a high impedance state. LVCMOS/LVTTL interface levels.
6	MR	Input	Pulldown	Active HIGH Master Reset. When logic HIGH, the internal dividers are reset causing the outputs to go low. When logic LOW, the internal dividers and the outputs are enabled. LVCMOS/LVTTL interface levels.
7	nPLL_SEL	Input	Pulldown	PLL Bypass. When LOW, the output is driven from the VCO output. When HIGH, the PLL is bypassed and the output frequency = reference clock frequency/N output divider. LVCMOS/LVTTL interface levels.
8	V <sub>DDA</sub>	Power		Analog supply pin.
10	V <sub>DD</sub>	Power		Core supply pin.
11, 12	XTAL_OUT, XTAL_IN	Input		Crystal oscillator interface. XTAL_OUT is the output. XTAL_IN is the input.
13, 19	GND	Power		Power supply ground.
14, 15 17, 18	Q3, Q2, Q1, Q0	Output		Single-ended clock outputs. LVCMOS/LVTTL interface levels. 17Ω typical output impedance.
16	V <sub>DDO</sub>	Power		Output supply pin.

NOTE: Pullup and Pulldown refer to internal input resistors. See Table 2, Pin Characteristics, for typical values.

TABLE 2. PIN CHARACTERISTICS

Symbol	Parameter	Test Conditions	Minimum	Typical	Maximum	Units
C <sub>IN</sub>	Input Capacitance			4		pF
C <sub>PD</sub>	Power Dissipation Capacitance			8		pF
R <sub>PULLUP</sub>	Input Pullup Resistor			51		kΩ
R <sub>PULLDOWN</sub>	Input Pulldown Resistor			51		kΩ
R <sub>OUT</sub>	Output Impedance	V <sub>DDO</sub> = 3.3V±5%		17		Ω
		V <sub>DDO</sub> = 2.5V±5%		21		Ω

## ABSOLUTE MAXIMUM RATINGS

Supply Voltage, $V_{DD}$	4.6V
Inputs, $V_I$	-0.5V to $V_{DD} + 0.5$ V
Outputs, $V_O$	-0.5V to $V_{DD} + 0.5$ V
Package Thermal Impedance, $\theta_{JA}$	73.2°C/W (0 lfpm)
Storage Temperature, $T_{STG}$	-65°C to 150°C

NOTE: Stresses beyond those listed under Absolute Maximum Ratings may cause permanent damage to the device. These ratings are stress specifications only. Functional operation of product at these conditions or any conditions beyond those listed in the *DC Characteristics* or *AC Characteristics* is not implied. Exposure to absolute maximum rating conditions for extended periods may affect product reliability.

**TABLE 3A. POWER SUPPLY DC CHARACTERISTICS,  $V_{DD} = V_{DDA} = 3.3V \pm 5\%$ ,  $V_{DDO} = 3.3V \pm 5\%$  OR  $2.5V \pm 5\%$ ,  $T_A = 0^\circ\text{C}$  TO  $70^\circ\text{C}$**

Symbol	Parameter	Test Conditions	Minimum	Typical	Maximum	Units
$V_{DD}$	Core Supply Voltage		3.135	3.3	3.465	V
$V_{DDA}$	Analog Supply Voltage		3.135	3.3	3.465	V
$V_{DDO}$	Output Supply Voltage		3.135	3.3	3.465	V
			2.375	2.5	2.625	V
$I_{DD}$	Power Supply Current				100	mA
$I_{DDA}$	Analog Supply Current				12	mA
$I_{DDO}$	Output Supply Current				10	mA

**TABLE 3B. LVCMOS/LVTTL DC CHARACTERISTICS,  $V_{DD} = V_{DDA} = 3.3V \pm 5\%$ ,  $V_{DDO} = 3.3V \pm 5\%$  OR  $2.5V \pm 5\%$ ,  $T_A = 0^\circ\text{C}$  TO  $70^\circ\text{C}$**

Symbol	Parameter	Test Conditions	Minimum	Typical	Maximum	Units
$V_{IH}$	Input High Voltage		2		$V_{DD} + 0.3$	V
$V_{IL}$	Input Low Voltage		-0.3		0.8	V
$I_{IH}$	Input High Current	OE, F_SEL0:1	$V_{DD} = V_{IN} = 3.465\text{V}$		5	$\mu\text{A}$
		nPLL_SEL, MR, nXTAL_SEL, REF_CLK	$V_{DD} = V_{IN} = 3.465\text{V}$		150	$\mu\text{A}$
$I_{IL}$	Input Low Current	OE, F_SEL0:1	$V_{DD} = 3.465\text{V}$ , $V_{IN} = 0\text{V}$	-150		$\mu\text{A}$
		nPLL_SEL, MR, nXTAL_SEL, REF_CLK	$V_{DD} = 3.465\text{V}$ , $V_{IN} = 0\text{V}$	-5		$\mu\text{A}$
$V_{OH}$	Output High Voltage; NOTE 1		$V_{DDO} = 3.3V \pm 5\%$	2.6		V
			$V_{DDO} = 2.5V \pm 5\%$	1.8		V
$V_{OL}$	Output Low Voltage; NOTE 1		$V_{DDO} = 3.3V$ or $2.5V \pm 5\%$		0.5	V

NOTE 1: Outputs terminated with  $50\Omega$  to  $V_{DDO}/2$ . See Parameter Measurement Information, Output Load Test Circuit.

**TABLE 4. CRYSTAL CHARACTERISTICS**

Parameter	Test Conditions	Minimum	Typical	Maximum	Units
Mode of Oscillation		Fundamental			
Frequency			25		MHz
Equivalent Series Resistance (ESR)				50	$\Omega$
Shunt Capacitance				7	pF
Drive Level				1	mW

NOTE: Characterized using an 18pF parallel resonant crystal.

**TABLE 5A. AC CHARACTERISTICS,  $V_{DD} = V_{DDA} = V_{DDO} = 3.3V \pm 5\%$ ,  $T_A = 0^\circ C$  TO  $70^\circ C$** 

Symbol	Parameter	Test Conditions	Minimum	Typical	Maximum	Units
$f_{OUT}$	Output Frequency	F_SEL[1:0] = 00	140	156.25	175	MHz
		F_SEL[1:0] = 01 or 11	112	125	140	MHz
		F_SEL[1:0] = 10	56	62.5	70	MHz
tsk(o)	Output Skew; NOTE 1, 2			60	ps	
fjit( $\emptyset$ )	RMS Phase Jitter (Random); NOTE 3	156.25MHz, (1.875MHz - 20MHz)		0.52		ps
		125MHz, (1.875MHz - 20MHz)		0.65		ps
		62.5MHz, (1.875MHz - 20MHz)		0.55		ps
$t_R / t_F$	Output Rise/Fall Time	20% to 80%	200		700	ps
odc	Output Duty Cycle	F_SEL[1:0] = 00 or 01	43		57	%
		F_SEL[1:0] = 10 or 11	49		51	%

NOTE 1: Defined as skew between outputs at the same supply voltages and with equal load conditions. Measured at  $V_{DDO}/2$ .

NOTE 2: This parameter is defined in accordance with JEDEC Standard 65.

NOTE 3: Please refer to the Phase Noise Plot.

**TABLE 5B. AC CHARACTERISTICS,  $V_{DD} = V_{DDA} = 3.3V \pm 5\%$ ,  $V_{DDO} = 2.5V \pm 5\%$ ,  $T_A = 0^\circ C$  TO  $70^\circ C$** 

Symbol	Parameter	Test Conditions	Minimum	Typical	Maximum	Units
$f_{OUT}$	Output Frequency	F_SEL[1:0] = 00	140	156.25	175	MHz
		F_SEL[1:0] = 01 or 11	112	125	140	MHz
		F_SEL[1:0] = 10	56	62.5	70	MHz
tsk(o)	Output Skew; NOTE 1, 2			60	ps	
fjit( $\emptyset$ )	RMS Phase Jitter (Random); NOTE 3	156.25MHz, (1.875MHz - 20MHz)		0.48		ps
		125MHz, (1.875MHz - 20MHz)		0.59		ps
		62.5MHz, (1.875MHz - 20MHz)		0.53		ps
$t_R / t_F$	Output Rise/Fall Time	20% to 80%	200		700	ps
odc	Output Duty Cycle	F_SEL[1:0] = 00 or 01	43		57	%
		F_SEL[1:0] = 10 or 11	49		51	%

NOTE 1: Defined as skew between outputs at the same supply voltages and with equal load conditions. Measured at  $V_{DDO}/2$ .

NOTE 2: This parameter is defined in accordance with JEDEC Standard 65.

NOTE 3: Please refer to the Phase Noise Plot.

**TYPICAL PHASE NOISE AT 62.5MHz @3.3V**

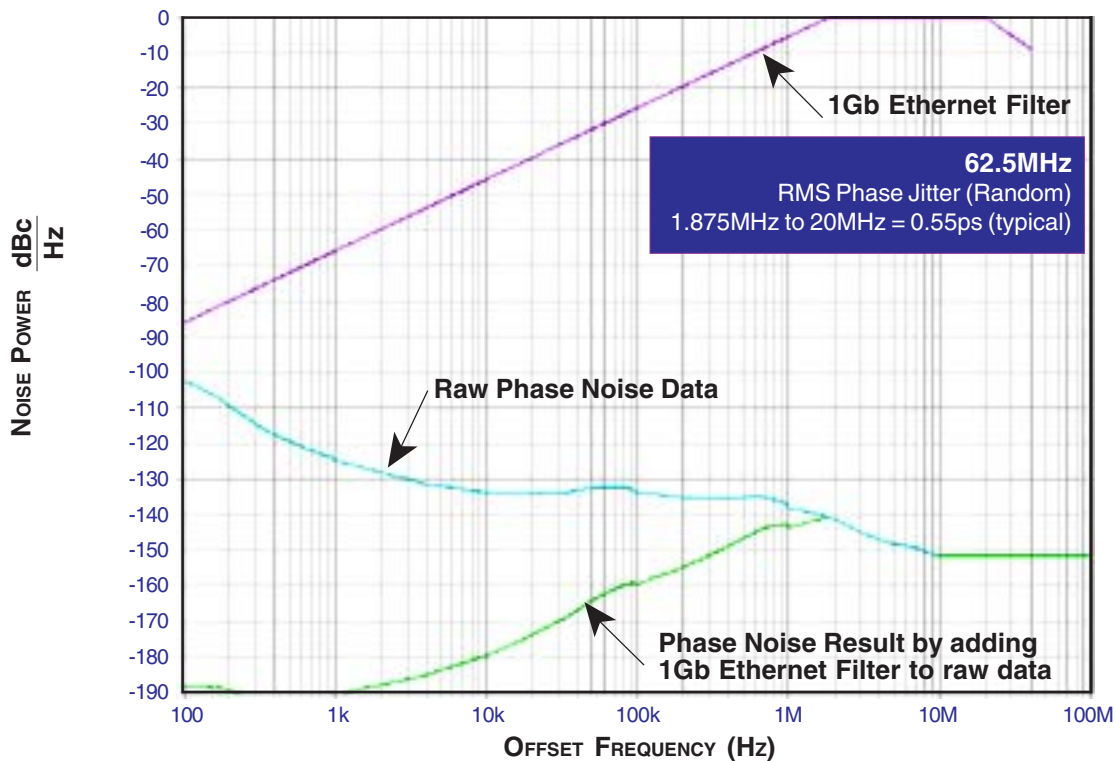

**TYPICAL PHASE NOISE AT 62.5MHz @2.5V**

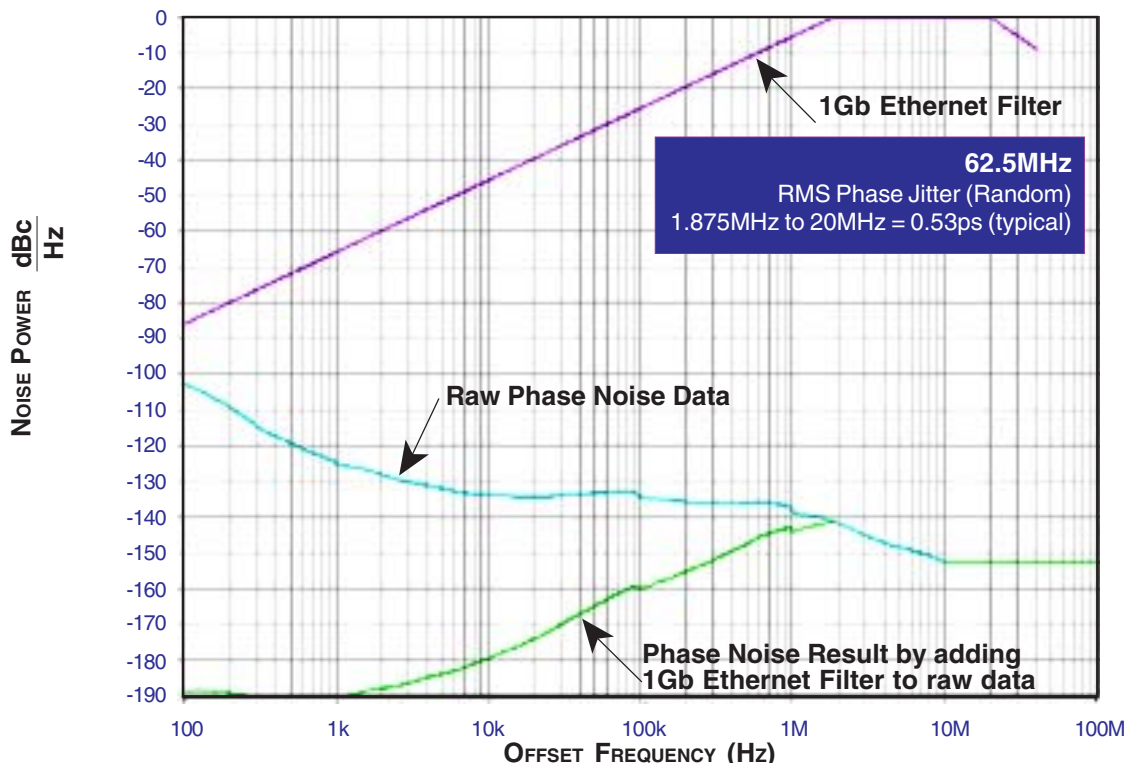

TYPICAL PHASE NOISE AT 125MHz @3.3V

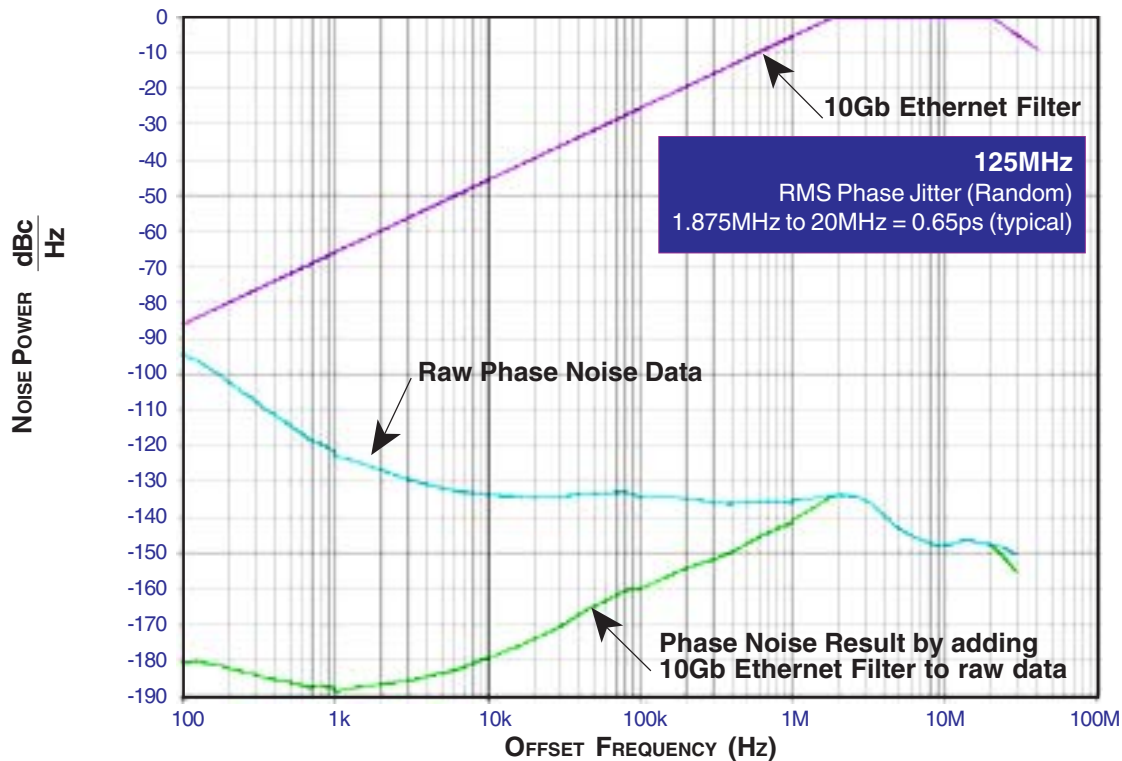

TYPICAL PHASE NOISE AT 156.25MHz @3.3V

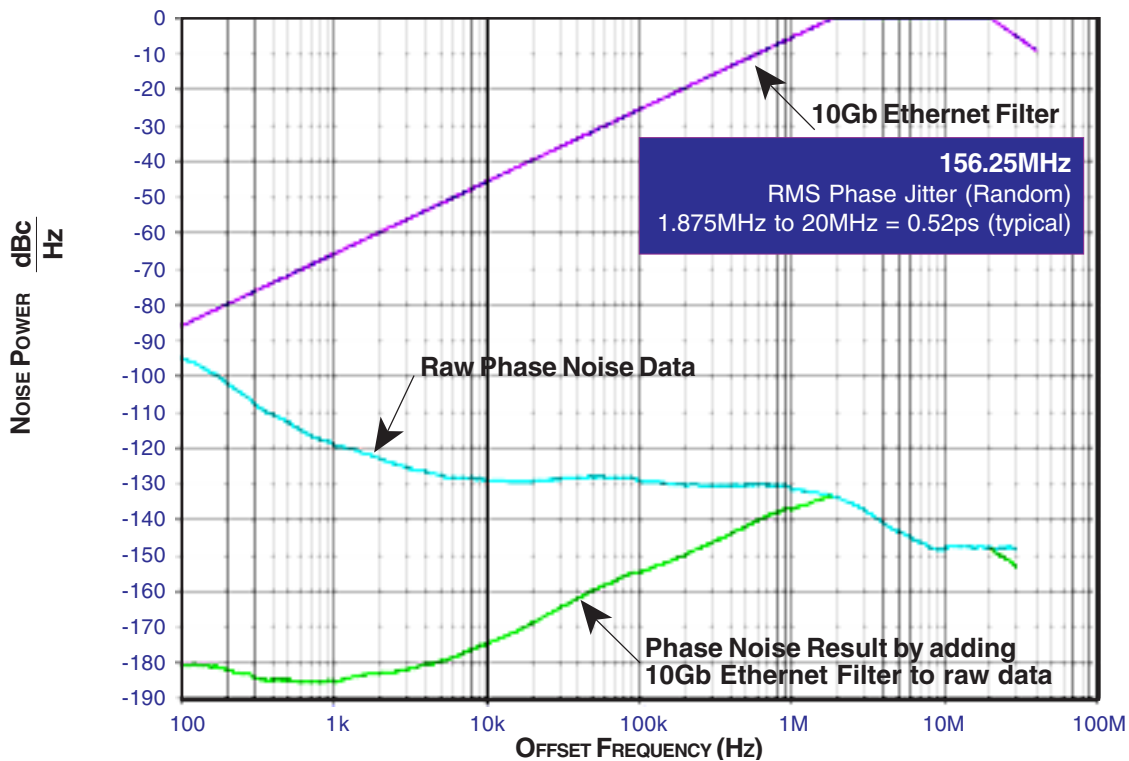

## PARAMETER MEASUREMENT INFORMATION

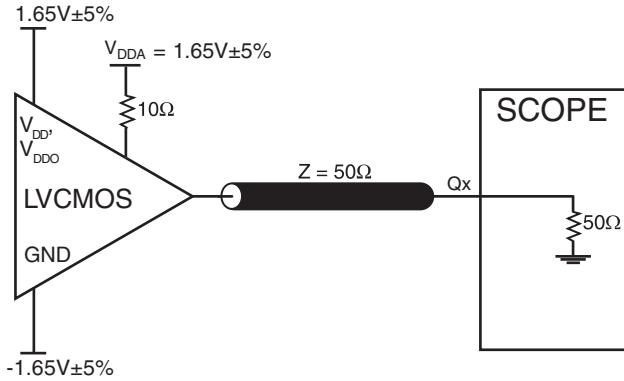

3.3V CORE/3.3V OUTPUT LOAD AC TEST CIRCUIT

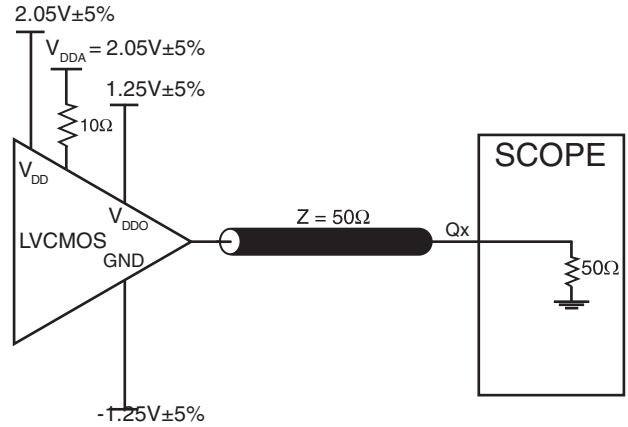

3.3V CORE/2.5V OUTPUT LOAD AC TEST CIRCUIT

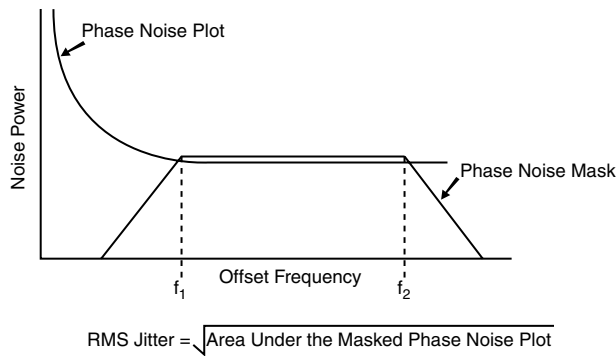

RMS PHASE JITTER

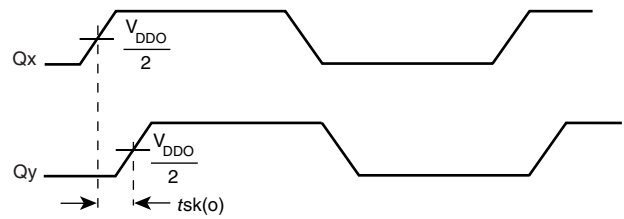

OUTPUT SKEW

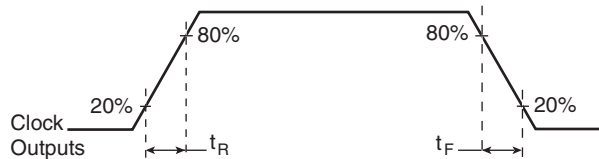

OUTPUT RISE/FALL TIME

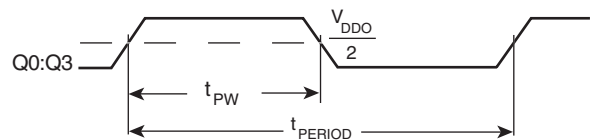

$$\text{odc} = \frac{t_{PW}}{t_{PERIOD}} \times 100\%$$

OUTPUT DUTY CYCLE/PULSE WIDTH/PERIOD

## APPLICATION INFORMATION

### POWER SUPPLY FILTERING TECHNIQUES

As in any high speed analog circuitry, the power supply pins are vulnerable to random noise. The ICS840004-01 provides separate power supplies to isolate any high switching noise from the outputs to the internal PLL.  $V_{DD}$ ,  $V_{DDA}$ , and  $V_{DDO}$  should be individually connected to the power supply plane through vias, and bypass capacitors should be used for each pin. To achieve optimum jitter performance, power supply isolation is required. *Figure 1* illustrates how a  $10\Omega$  resistor along with a  $10\mu\text{F}$  and a  $.01\mu\text{F}$  bypass capacitor should be connected to each  $V_{DDA}$ .

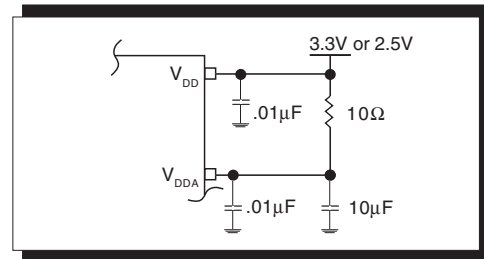

FIGURE 1. POWER SUPPLY FILTERING

### CRYSTAL INPUT INTERFACE

The ICS840004-01 has been characterized with  $18\text{pF}$  parallel resonant crystals. The capacitor values shown in *Figure 2* below were determined using a  $25\text{MHz}$ ,  $18\text{pF}$

parallel resonant crystal and were chosen to minimize the ppm error.

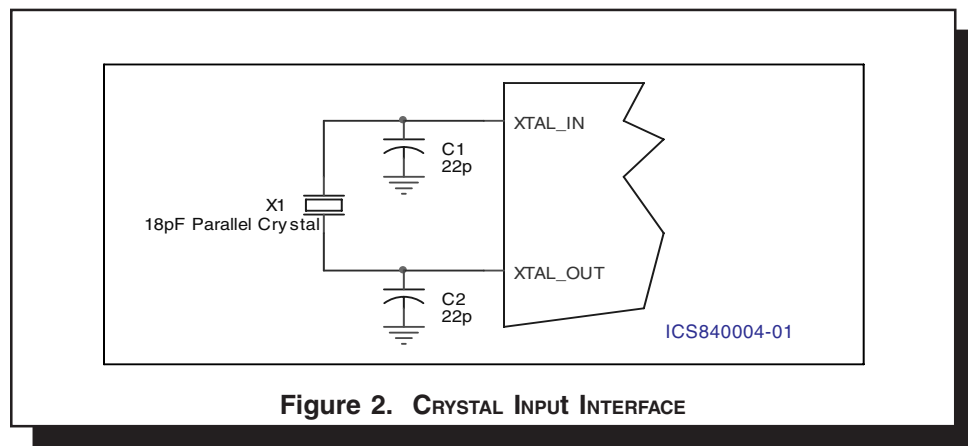

Figure 2. CRYSTAL INPUT INTERFACE



## LVCMOS TO XTAL INTERFACE

The XTAL\_IN input can accept a single-ended LVCMOS signal through an AC couple capacitor. A general interface diagram is shown in *Figure 3*. The XTAL\_OUT pin can be left floating. The input edge rate can be as slow as 10ns. For LVCMOS inputs, it is recommended that the amplitude be reduced from full swing to half swing in order to prevent signal interference with the power rail and to reduce noise. This configuration requires that the output

impedance of the driver ( $R_o$ ) plus the series resistance ( $R_s$ ) equals the transmission line impedance. In addition, matched termination at the crystal input will attenuate the signal in half. This can be done in one of two ways. First,  $R_1$  and  $R_2$  in parallel should equal the transmission line impedance. For most  $50\Omega$  applications,  $R_1$  and  $R_2$  can be  $100\Omega$ . This can also be accomplished by removing  $R_1$  and making  $R_2$   $50\Omega$ .

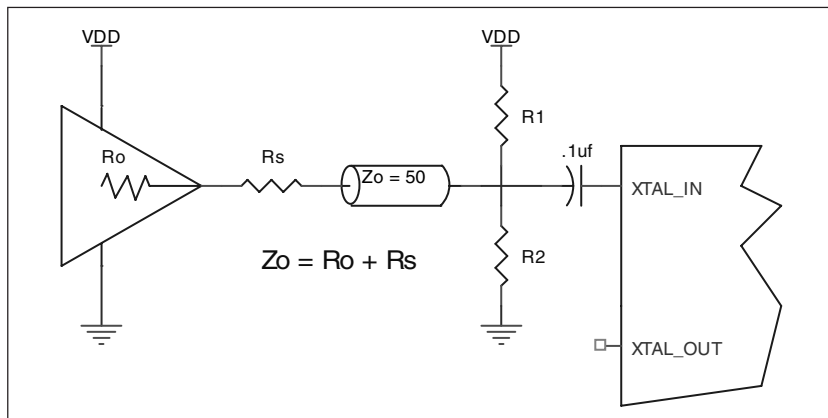

Figure 3. GENERAL DIAGRAM FOR LVCMOS DRIVER TO XTAL INPUT INTERFACE

## RECOMMENDATIONS FOR UNUSED INPUT AND OUTPUT PINS

### NPPTS:

#### CRYSTAL INPUT:

For applications not requiring the use of the crystal oscillator input, both XTAL\_IN and XTAL\_OUT can be left floating. Though not required, but for additional protection, a  $1k\Omega$  resistor can be tied from XTAL\_IN to ground.

#### REF\_CLK INPUT:

For applications not requiring the use of the reference clock, it can be left floating. Though not required, but for additional protection, a  $1k\Omega$  resistor can be tied from the REF\_CLK to ground.

#### LVCMOS CONTROL PINS:

All control pins have internal pull-ups or pull-downs; additional resistance is not required but can be added for additional protection. A  $1k\Omega$  resistor can be used.

### OUTPUTS:

#### LVCMOS OUTPUT:

All unused LVCMOS output can be left floating. We recommend that there is no trace attached.

**LAYOUT GUIDELINE**

Figure 4 shows a schematic example of the ICS840004-01. An example of LVCMOS termination is shown in this schematic. Additional LVCMOS termination approaches are shown in the LVCMOS Termination Application Note. In this example, an 18pF parallel resonant 25MHz crystal is used. The

C1=22pF and C2=22pF are recommended for frequency accuracy. For different board layout, the C1 and C2 may be slightly adjusted for optimizing frequency accuracy. 1KΩ pullup or pulldown resistors can be used for the logic control input pins.

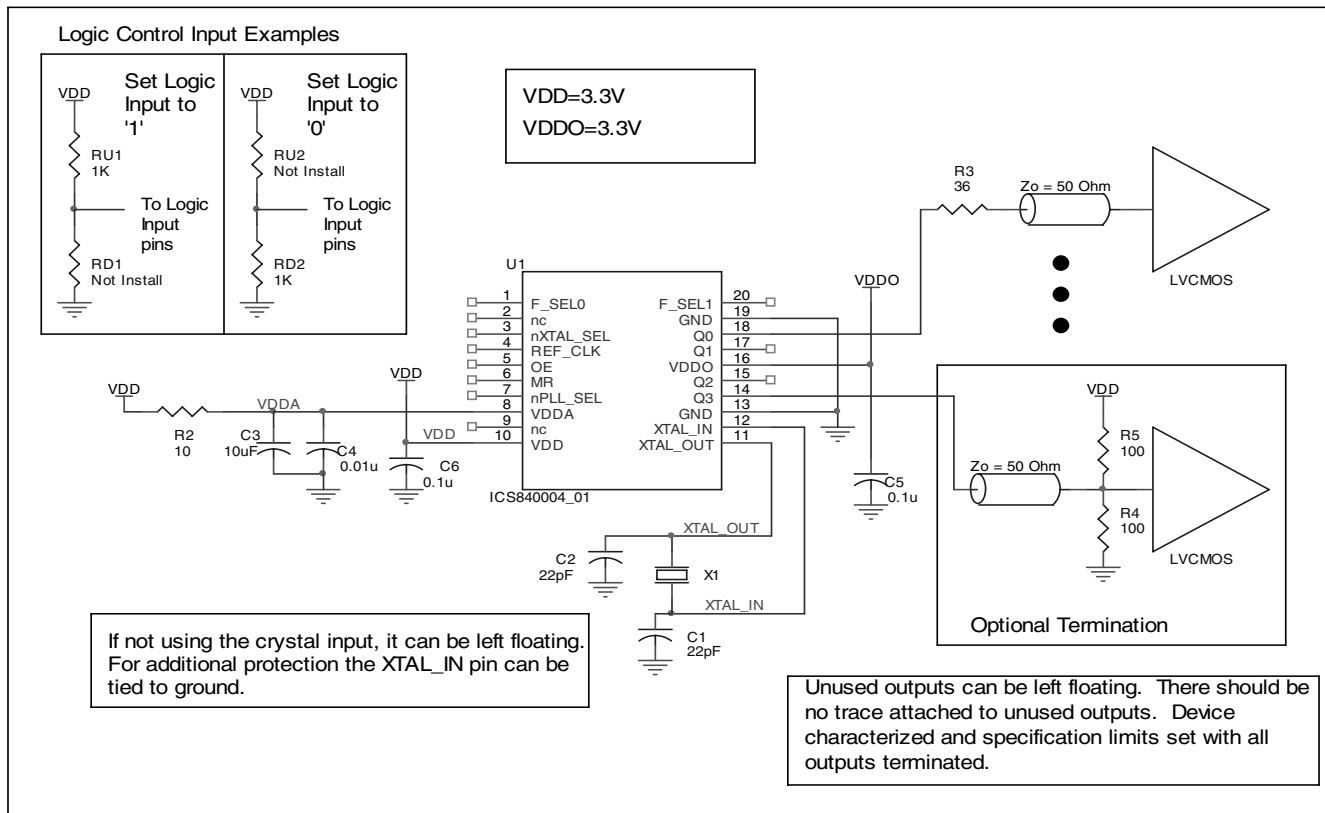

FIGURE 4. ICS840004-01 SCHEMATIC EXAMPLE

## RELIABILITY INFORMATION

TABLE 6.  $\theta_{JA}$  VS. AIR FLOW TABLE FOR 20 LEAD TSSOP

$\theta_{JA}$ by Velocity (Linear Feet per Minute)			
	0	200	500
Single-Layer PCB, JEDEC Standard Test Boards	114.5°C/W	98.0°C/W	88.0°C/W
Multi-Layer PCB, JEDEC Standard Test Boards	73.2°C/W	66.6°C/W	63.5°C/W

**NOTE:** Most modern PCB designs use multi-layered boards. The data in the second row pertains to most designs.

### TRANSISTOR COUNT

The transistor count for ICS840004-01 is: 3796

## PACKAGE OUTLINE - G SUFFIX FOR 20 LEAD TSSOP

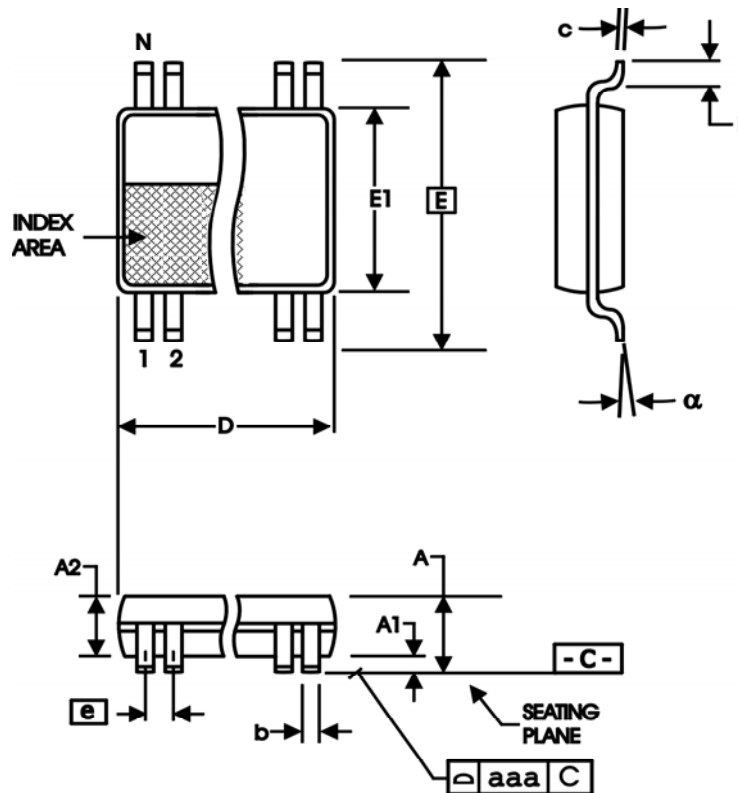

TABLE 7. PACKAGE DIMENSIONS

SYMBOL	Millimeters	
	MIN	MAX
N	20	
A	--	1.20
A1	0.05	0.15
A2	0.80	1.05
b	0.19	0.30
c	0.09	0.20
D	6.40	6.60
E	6.40 BASIC	
E1	4.30	4.50
e	0.65 BASIC	
L	0.45	0.75
$\alpha$	0°	8°
aaa	--	0.10

Reference Document: JEDEC Publication 95, MO-153

TABLE 8. ORDERING INFORMATION

Part/Order Number	Marking	Package	Shipping Packaging	Temperature
ICS840004AG-01	ICS840004A01	20 Lead TSSOP	tube	0°C to 70°C
ICS840004AG-01T	ICS840004A01	20 Lead TSSOP	tape & reel	0°C to 70°C
ICS840004AG-01LF	ICS40004A01L	20 Lead "Lead-Free" TSSOP	tube	0°C to 70°C
ICS840004AG-01LFT	ICS40004A01L	20 Lead "Lead-Free" TSSOP	tape & reel	0°C to 70°C

NOTE: Parts that are ordered with an LF suffix to the part number are the Pb-Free configuration and are RoHS compliant.

The aforementioned trademarks, HiPerClockS and FemtoClocks are trademarks of Integrated Circuit Systems, Inc. or its subsidiaries in the United States and/or other countries.

While the information presented herein has been checked for both accuracy and reliability, Integrated Circuit Systems, Incorporated (ICS) assumes no responsibility for either its use or for infringement of any patents or other rights of third parties, which would result from its use. No other circuits, patents, or licenses are implied. This product is intended for use in normal commercial and industrial applications. Any other applications such as those requiring high reliability or other extraordinary environmental requirements are not recommended without additional processing by ICS. ICS reserves the right to change any circuitry or specifications without notice. ICS does not authorize or warrant any ICS product for use in life support devices or critical medical instruments.

Innovate with IDT and accelerate your future networks. Contact:

**www.IDT.com**

**For Sales**

800-345-7015  
408-284-8200  
Fax: 408-284-2775

**For Tech Support**

clockhelp@idt.com  
408-284-8200

---

**Corporate Headquarters**

Integrated Device Technology, Inc.  
6024 Silver Creek Valley Road  
San Jose, CA 95138  
United States  
800 345 7015  
+408 284 8200 (outside U.S.)

**Asia Pacific and Japan**

Integrated Device Technology  
Singapore (1997) Pte. Ltd.  
Reg. No. 199707558G  
435 Orchard Road  
#20-03 Wisma Atria  
Singapore 238877  
+65 6 887 5505

**Europe**

IDT Europe, Limited  
Prime House  
Barnett Wood Lane  
Leatherhead, Surrey  
United Kingdom KT22 7DE  
+44 1372 363 339