



# PI6C970

## Pentium® Motherboard Clock Generator

### Features

- Four-skew controlled, low jitter CPU clock outputs (PCLK0-PCLK3) 66, 60, and 50 MHz selectable
- Six-skew controlled synchronous PCI clock outputs (BCLK0-BCLK5) at one-half of the CPU and synchronous
- 24 MHz floppy clock output
- 12 MHz keyboard clock output
- Two 14.318 MHz reference clock outputs: (REF1-REF0)
- Supports 3.3V operation
- Controlled output buffer rise/fall time
- Built in crystal oscillator circuit
- On-chip PLL loop filters
- Low power CMOS design
- Test mode support
- Packages available:
  - 28-pin 209-mil wide SSOP (H28)
  - 28-pin 300-mil wide SOIC (S28)

### CPU and PCI Bus Clock Outputs

Four selectable CPU clock outputs (PCLK0-3) and six PCI clock outputs (BCLK0-5) are provided. Output frequency of the CPU and PCI clock outputs are selected with input pins SEL0 and SEL1 as shown in Table 1.

**Table 1. Output Frequency Selection**

Select Address		CPU Clock:	PCI Clock
SEL1	SEL0	PCLK0-3 (MHz)	BCLK0-5 (MHz)
0	0	50	25
0	1	66.6	33.3
1	0	60	30
1	1	Test Mode	Test Mode

### Description

Pericom Semiconductor's PI6C series of clock generators are produced in the Company's advanced 0.8 micron CMOS process.

The PI6C970 clock generator provides a complete system clock solution for Intel Pentium motherboards with PCI buses. It is designed to fully meet Intel Pentium microprocessor and Intel Triton chipset requirements.

### Function Block Diagram

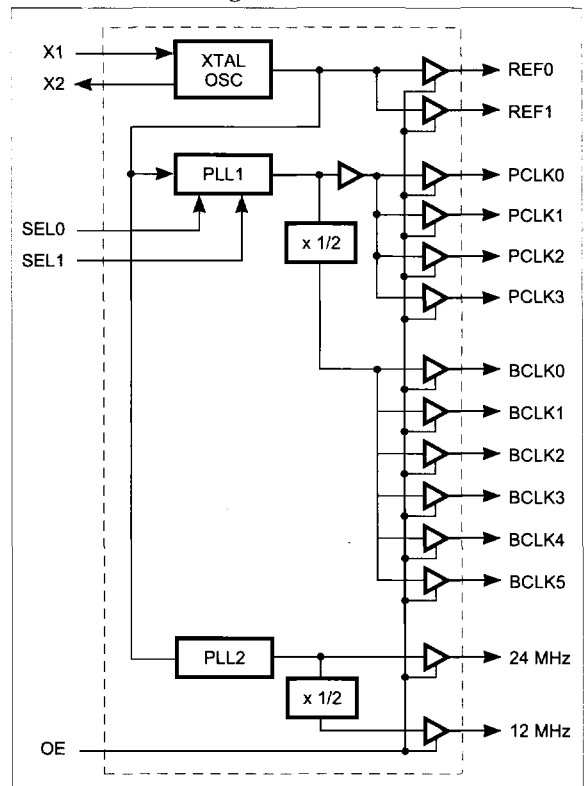

### Product Pin Configuration

VCC	1	28	REF0
X1	2	27	REF1
X2	3	26	VCC
GND	4	25	12 MHz
OE	5	24	24 MHz
PCLK0	6	23	GND
PCLK1	7	22	BCLK2
VCC	8	21	BCLK3
PCLK2	9	20	VCC
PCLK3	10	19	BCLK4
GND	11	18	BCLK5
SEL1	12	17	GND
SEL0	13	16	BCLK1
VCC	14	15	BCLK0

28-Pin  
H28  
S28

### Test Mode

The PI6C970 also includes a special test mode which can be used in production system verification (Table 1). When using the test mode, X1 is driven with an external clock (Reference Frequency) and the following output clock frequencies result:

### Reference Frequency

Device Pin	Output Frequency
REF0/1	Reference Frequency
12 MHz	Reference Frequency/8
24 MHz	Reference Frequency/4
BLK0-5	Reference Frequency/4
PCLK0-3	Reference Frequency/2

### Pin Descriptions

Pin Name	I/O	Description
12 MHz	O	Fixed 12 MHz output for keyboard clock application
24 MHz	O	Fixed 24 MHz output for floppy drive or Super I/O applications
BCLK0	O	Selectable frequency output for PCI bus clock applications
BCLK1	O	Selectable frequency output for PCI bus clock applications
BCLK2	O	Selectable frequency output for PCI bus clock applications
BCLK3	O	Selectable frequency output for PCI bus clock applications
BCLK4	O	Selectable frequency output for PCI bus clock applications
BCLK5	O	Selectable frequency output for PCI bus clock applications
GND	—	Ground connection
OE	I	Output Enable, puts all outputs in high impedance state when low. This input has internal pull-up device.
PCLK0	O	Selectable frequency output for CPU clock applications
PCLK1	O	Selectable frequency output for CPU clock applications
PCLK2	O	Selectable frequency output for CPU clock applications
PCLK3	O	Selectable frequency output for CPU clock applications
REF0	O	Fixed 14.318 MHz output for various motherboard functions
REF1	O	Fixed 14.318 MHz output for various motherboard functions
SEL0	I	Frequency Selection input. This input has internal pull-up device.
SEL1	I	Frequency Selection input. This input has internal pull-up device.
VCC	—	Power supply connection, 3.3V
X1	I	Crystal connection or external reference frequency input
X2	—	Crystal connection, leave unconnected when using external reference

### Maximum Ratings

(Above which the useful life may be impaired. For user guidelines, not tested.)

Storage Temperature .....	-65°C to +150°C
Ambient Temperature with Power Applied .....	0°C to +70°C
Supply Voltage to Ground Potential .....	-0.5V to +7.0V
DC Input Voltage .....	-0.5V to +7.0V
DC Output Current .....	120mA
Power Dissipation .....	0.5W

**Note:**

Stresses greater than those listed under MAXIMUM RATINGS may cause permanent damage to the device. This is a stress rating only and functional operation of the device at these or any other conditions above those indicated in the operational sections of this specification is not implied. Exposure to absolute maximum rating conditions for extended periods may affect reliability.

### DC Electrical Characteristics at 3.3V (Operating Range, VCC = +3.3V ±10%, Temperature 0°C to +70°C)

Parameters	Description	Test Conditions	Min.	Max.	Units
I <sub>IL</sub>	Input LOW Current, except X1	V <sub>IN</sub> = 0V	-5.0	5.0	μA
I <sub>IH</sub>	Input HIGH Current, except X1	V <sub>IN</sub> = V <sub>CC</sub>	-5.0	5.0	μA
I <sub>OL</sub>	Output LOW Current	V <sub>OL</sub> = 0.8V; for PCLKS & BCLKS, V <sub>CC</sub> = Min	30.0		mA
I <sub>OH</sub>	Output HIGH Current	V <sub>OL</sub> = 2.0V; for PCLKS & BCLKS, V <sub>CC</sub> = Min		-31.0	mA
I <sub>OL</sub>	Output LOW Current	V <sub>OL</sub> = 0.8V; for fixed CLKs, V <sub>CC</sub> = Min	25.0		mA
I <sub>OH</sub>	Output HIGH Current	V <sub>OL</sub> = 2.0V; for fixed CLKs, V <sub>CC</sub> = Min		-30.0	mA
V <sub>OL</sub>	Output LOW Voltage	I <sub>OL</sub> = 15mA; for PCLKS & BCLKS, V <sub>CC</sub> = Min		0.45	V
V <sub>OH</sub>	Output HIGH Voltage	I <sub>OH</sub> = 20mA; for PCLKS & BCLKS, V <sub>CC</sub> = Min	2.4		V
V <sub>OL</sub>	Output LOW Voltage	I <sub>OL</sub> = 12.5mA; for fixed CLKs, V <sub>CC</sub> = Min		0.45	V
V <sub>OH</sub>	Output HIGH Voltage	I <sub>OH</sub> = 20mA; for fixed CLKs, V <sub>CC</sub> = Min	2.4		V
I <sub>CC</sub>	Supply Current	@66.66 MHz; all outputs unloaded		110	mA

**AC Electrical Characteristics<sup>(1)</sup>** (Operating Range, VCC = 3.3V ±10%, Temperature 0°C to 70°C)

Symbol	Description	Test Conditions	Min.	Typ.	Max.	Units
<b>Processor Clock Outputs, PCLK0-3:</b>						
T <sub>jab</sub>	Output Clock Jitter, Absolute				±250	ps
t <sub>sk</sub>	Output Clock Skew	Between any two outputs			250	ps
t <sub>p</sub>	Period Time (50 MHz)		20.0			ns
t <sub>H/L</sub>	High/Low Time (50 MHz)	Above 2.4V, Below 0.4V	4.0			ns
t <sub>p</sub>	Period Time (60 MHz)		16.7			ns
t <sub>H/L</sub>	High/Low Time (60 MHz)	Above 2.4V, Below 0.4V	4.0			ns
t <sub>p</sub>	Period Time (66 MHz)		15.0			ns
t <sub>H/L</sub>	High/Low Time (66 MHz)	Above 2.4V, Below 0.4V	4.0			ns
<b>Bus Clock Outputs, BCLK0-5:</b>						
T <sub>jab</sub>	Output Clock Jitter, Absolute				±350	ps
t <sub>sk</sub>	Output Clock Skew	Between any two outputs			500	ps
t <sub>p</sub>	Period Time (25 MHz)		40.0			ns
t <sub>H/L</sub>	High/Low Time (25 MHz)	Above 2.4V, Below 0.4V	16.0			ns
t <sub>p</sub>	Period Time (30 MHz)		33.3			ns
t <sub>H/L</sub>	High/Low Time (30 MHz)	Above 2.4V, Below 0.4V	13.0			ns
t <sub>p</sub>	Period Time (33 MHz)		30.0			ns
t <sub>H/L</sub>	High/Low Time (33 MHz)	Above 2.4V, Below 0.4V	12.0			ns
T <sub>SK</sub>	Skew from PCLK <sub>x</sub> to BCLK <sub>x</sub> <sup>(2)</sup>		1.0		5.0	ns
<b>Regarding All Clock Outputs:</b>						
d <sub>t</sub>	Output Duty Cycle		45	50	55	%
t <sub>r</sub>	Output Rise Time	From 0.4V to 2.4V	1.0		4.0	ns
t <sub>f</sub>	Output Fall Time	From 2.4V to 0.4V	1.0		24.0	ns
T <sub>PU</sub>	Stabilization Time from Power-Up	Within 0.1% of Final Freq.			3.0	ms
f <sub>d</sub>	Long-Term Output Frequency Stability <sup>(3)</sup>	Over Vcc and T <sub>A</sub> Range			0.1	%

**Notes:**

- All AC tests are performed with the following load conditions: PCLK0-3 = 20 pF, BCLK0-5 = 30 pF, 24 MHz = 20 pF, 12 MHz = 20 pF, REF0 = 30 pF, and REF1 = 15 pF. Threshold voltage for duty cycle and timing measurements is 1.5V.
- PCLK outputs lead BCLK outputs.
- Output Frequency Stability is solely determined by crystal oscillator frequency shift.