

Product Features

- Compatible with LCX™ and LVT™ families of products
- Supports 5V tolerant mixed signal mode operation
 - Input can be 3V or 5V
 - Output can be 3V or connected to 5V bus
- Advanced low power CMOS operation
- Excellent output drive capability:
Balanced drives (24 mA sink and source)
- Low ground bounce outputs
- Hysteresis on all inputs
- Industrial operating temperature range: -40°C to +85°C
- Packages available:
 - 20-pin 173-mil wide plastic TSSOP (L20)
 - 20-pin 150-mil wide plastic QSOP (Q20)
 - 20-pin 150-mil wide plastic TQSOP (R20)
 - 20-pin 300-mil wide plastic SOIC (S20)

Product Description

Pericom Semiconductor's PI74LPT series of logic circuits are produced using the Company's advanced 0.6 micron CMOS technology, achieving industry leading speed grades.

The PI74LPT241 is an 8-bit buffer/line driver designed for driving high capacitive memory loads. With its balanced-drive characteristics, this high-speed, low power device provides lower ground bounce, transmission line matching of signals, fewer line reflections and lower EMI and RFI effects. This makes it ideal for driving on-board buses and transmission lines.

The PI74LPT241 can be driven from either 3.3V or 5.0V devices allowing this device to be used as a translator in a mixed 3.3/5.0V system.

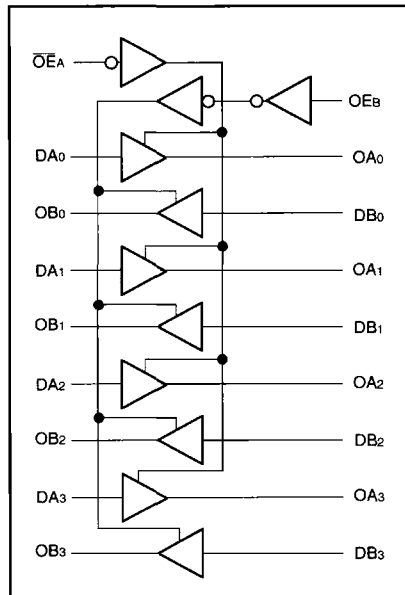
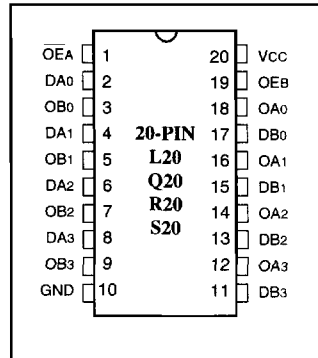
Logic Block Diagram

Product Pin Configuration

Product Pin Description

Pin Name	Description
$\overline{OE_A}, \overline{OE_B}$	3-State Output Enable Inputs
D_{xx}	Inputs
O_{xx}	Outputs
GND	Ground
VCC	Power

Truth Table⁽¹⁾

Inputs			Outputs
$\overline{OE_A}$	$\overline{OE_B}$	D_{xx}	O_{xx}
L	H	L	L
L	H	H	H
H	L	X	Z

Note:

1. H = High Voltage Level, X = Don't Care,
L = Low Voltage Level, Z = High Impedance

Maximum Ratings

(Above which the useful life may be impaired. For user guidelines, not tested.)

Storage Temperature	-65°C to +150°C
Ambient Temperature with Power Applied	-40°C to +85°C
Supply Voltage to Ground Potential (Inputs & Vcc Only)	-0.5V to +7.0V
Supply Voltage to Ground Potential (Outputs & D/O Only)	-0.5V to +7.0V
DC Input Voltage	-0.5V to +7.0V
DC Output Current	120mA
Power Dissipation	1.0W

Note:

Stresses greater than those listed under MAXIMUM RATINGS may cause permanent damage to the device. This is a stress rating only and functional operation of the device at these or any other conditions above those indicated in the operational sections of this specification is not implied. Exposure to absolute maximum rating conditions for extended periods may affect reliability.

DC Electrical Characteristics (Over the Operating Range, TA = -40°C to +85°C, VCC = 2.7V to 3.6V)

Parameters	Description	Test Conditions ⁽¹⁾		Min.	Typ ⁽²⁾	Max.	Units
VIH	Input HIGH Voltage (Input pins)	Guaranteed Logic HIGH Level		2.2	—	5.5	V
	Input HIGH Voltage (I/O pins)			2.0	—	5.5	V
VIL	Input LOW Voltage (Input and I/O pins)	Guaranteed Logic LOW Level		-0.5	—	0.8	V
IIH	Input HIGH Current (Input pins)	VCC = Max.	VIN = 5.5V	—	—	±1	µA
	Input HIGH Current (I/O pins)	VCC = Max.	VIN = VCC	—	—	±1	µA
IIL	Input LOW Current (Input pins)	VCC = Max.	VIN = GND	—	—	±1	µA
	Input LOW Current (I/O pins)	VCC = Max.	VIN = GND	—	—	±1	µA
IOZH	High Impedance Output Current (3-State Output pins)	VCC = Max.	VOUT = 5.5V	—	—	±1	µA
IOZL		VCC = Max.	VOUT = GND	—	—	±1	µA
VIK	Clamp Diode Voltage	VCC = Min., IIN = -18 mA		—	-0.7	-1.2	V
IODH	Output HIGH Current	VCC = 3.3V, VIN = VIH or VIL, VO = 1.5V ⁽³⁾		-36	-60	-110	mA
IODL	Output LOW Current	VCC = 3.3V, VIN = VIH or VIL, VO = 1.5V ⁽³⁾		50	90	200	mA
VOH	Output HIGH Voltage	VCC = Min.	IOH = -0.1 mA	VCC-0.2	—	—	V
		VIN = VIH or VIL	IOH = -3 mA	2.4	3.0	—	V
		VCC = 3.0V,	IOH = -8 mA	2.4 ⁽⁵⁾	3.0	—	V
		VIN = VIH or VIL	IOH = -24 mA	2.0	—	—	V
VOL	Output LOW Voltage	VCC = Min.	IOL = 0.1 mA	—	—	0.2	V
		VIN = VIH or VIL	IOL = 16 mA	—	0.2	0.4	V
			IOL = 24 mA	—	0.3	0.5	V
IOS	Short Circuit Current ⁽⁴⁾	VCC = Max. ⁽³⁾ , VOUT = GND		-60	-85	-240	mA
IOFF	Power Down Disable	VCC = 0V, VIN or VOUT ≤ 4.5V		—	—	±100	µA
VH	Input Hysteresis			—	150	—	mV

Notes:

- For Max. or Min. conditions, use appropriate value specified under Electrical Characteristics for the applicable device type.
- Typical values are at VCC = 3.3V, +25°C ambient and maximum loading.
- Not more than one output should be shorted at one time. Duration of the test should not exceed one second.
- This parameter is guaranteed but not tested.
- VOH = VCC - 0.6V at rated current.

Capacitance (TA = 25°C, f = 1 MHz)

Parameters ⁽¹⁾	Description	Test Conditions	Typ.	Max.	Units
CIN	Input Capacitance	VIN = 0V	4.5	6	pF
COUT	Output Capacitance	VOUT = 0V	5.5	8	pF

Note:

- This parameter is determined by device characterization but is not production tested.

Power Supply Characteristics

Parameters	Description	Test Conditions ⁽¹⁾		Min.	Typ ⁽²⁾	Max.	Units
I _{cc}	Quiescent Power Supply Current	V _{CC} = Max.	V _{IN} = GND or V _{CC}		0.1	10	μA
ΔI _{cc}	Quiescent Power Supply Current TTL Inputs HIGH	V _{CC} = Max.	V _{IN} = V _{CC} - 0.6V ⁽³⁾		2.0	30	μA
I _{CCD}	Dynamic Power Supply ⁽⁴⁾	V _{CC} = Max., Outputs Open O _{EX} = GND One Bit Toggling 50% Duty Cycle	V _{IN} = V _{CC} V _{IN} = GND		50	75	μA/ MHz
I _c	Total Power Supply Current ⁽⁶⁾	V _{CC} = Max., Outputs Open f _i = 10 MHz 50% Duty Cycle O _{EX} = GND One Bit Toggling	V _{IN} = V _{CC} - 0.6V V _{IN} = GND		0.6	2.3	mA
		V _{CC} = Max., Outputs Open f _i = 2.5 MHz 50% Duty Cycle O _{EX} = GND 8 Bits Toggling	V _{IN} = V _{CC} - 0.6V V _{IN} = GND		2.1	4.7 ⁽⁵⁾	

Notes:

- For Max. or Min. conditions, use appropriate value specified under Electrical Characteristics for the applicable device.
- Typical values are at V_{CC} = 3.3V, +25°C ambient.
- Per TTL driven input; all other inputs at V_{CC} or GND.
- This parameter is not directly testable, but is derived for use in Total Power Supply Calculations.
- Values for these conditions are examples of the I_{cc} formula. These limits are guaranteed but not tested.
- I_c = I_{QUIESCENT} + I_{INPUTS} + I_{DYNAMIC}

$$I_c = I_{CC} + \Delta I_{CC} D_H N_T + I_{CCD} (f_{CP}/2 + f_i N_i)$$

$$I_{CC} = \text{Quiescent Current (I}_{CC1}, I_{CC2} \text{ and } I_{CCZ})$$

$$\Delta I_{CC} = \text{Power Supply Current for a TTL High Input}$$

$$D_H = \text{Duty Cycle for TTL Inputs High}$$

$$N_T = \text{Number of TTL Inputs at } D_H$$

$$I_{CCD} = \text{Dynamic Current Caused by an Input Transition Pair (HLH or LHL)}$$

$$f_{CP} = \text{Clock Frequency for Register Devices (Zero for Non-Register Devices)}$$

$$N_{CP} = \text{Number of Clock Inputs at } f_{CP}$$

$$f_i = \text{Input Frequency}$$

$$N_i = \text{Number of Inputs at } f_i$$

All currents are in milliamps and all frequencies are in megahertz.

Switching Characteristics over Operating Range⁽¹⁾

Parameters	Description	Conditions ⁽²⁾	LPT241		LPT241A		LPT241C		Units
			Com.		Com.		Com.		
			Min. ⁽³⁾	Max.	Min. ⁽³⁾	Max.	Min. ⁽³⁾	Max.	
tPLH tPHL	Propagation Delay Dxx to Oxx	CL = 50 pF RL = 500Ω	1.5	6.5	1.5	4.8	1.5	4.1	ns
tPZH tPZL	Output Enable Time \overline{OE}_A/OE_B to Oxx		1.5	8.0	1.5	6.2	1.5	5.8	ns
tPHZ tPLZ	Output Disable Time ⁽⁴⁾ \overline{OE}_A/OE_B to Oxx		1.5	7.0	1.5	5.6	1.5	5.2	ns
tsk(o)	Output Skew ⁽⁵⁾			0.5		0.5		0.5	ns

Notes:

1. Propagation Delays and Enable/Disable times are with $V_{CC} = 3.3V \pm 0.3V$, normal range. For $V_{CC} = 2.7V$, extended range, all Propagation Delays and Enable/Disable times should be degraded by 20%.
2. See test circuit and waveforms.
3. Minimum limits are guaranteed but not tested on Propagation Delays.
4. This parameter is guaranteed but not production tested.
5. Skew between any two outputs, of the same package, switching in the same direction. This parameter is guaranteed by design.