

Datasheet

FS8853

300 mA LDO Linear Regulator

Fortune Semiconductor Corporation

富晶電子股份有限公司

28F., No.27, Sec. 2, Zhongzheng E. Rd.,
Danshui Town, Taipei County 251, Taiwan

Tel. : 886-2-28094742

Fax : 886-2-28094874

www.ic-fortune.com

This manual contains new product information. **Fortune Semiconductor Corporation** reserves the rights to modify the product specification without further notice. No liability is assumed by **Fortune Semiconductor Corporation** as a result of the use of this product. No rights under any patent accompany the sale of the product.

1. General Description

The FS8853 is a low-dropout linear regulator that operations in the input voltage range from +2.5V to +9.0V and delivers 300mA output current.

The high-accuracy output voltage is preset at an internally trimmed voltage 2.5V or 3.3V. Other output voltages can be mask-optioned from 1.5V to 5.0V with 100mV increment, except FS8853-29Cx which has 2.85V output voltage.

The FS8853 consists of a 1.25V bandgap reference, an error amplifier, and a P-channel pass transistor. Other features include short-circuit protection and thermal shutdown protection. The FS8853 devices are available in TO-92, SOT-89 and SOT-23 packages.

2. Features

- Low dropout voltage 400mV at 300mA (Typ.)
- Up to ±35mV output voltage accuracy ($V_{IN} \leq 7V$)
- Preset at 2.5V, 3.3V
- Mask options from 1.5V to 5.0V
- Quiescent current 30µA at 5V input (Typ.)
- Small output capacitor
- Output current limit
- Thermal overload shutdown protection
- TO-92, SOT-89 and SOT-23 Package

3. Applications

- Battery Powered Equipment
- Palmtops
- Portable Cameras and Video Recorders
- Reference Voltage Sources
- Post Regulator for Switching Power

4. Ordering Information

FS8853-xx x x

Package	Pin Out		
A : SOT-23	1.IN	2.GND	3.OUT
B : SOT-23	1.GND	2.IN	3.OUT
C : SOT-23	1.GND	2.OUT	3.IN
E : TO-92	1.GND	2.IN	3.OUT
L : SOT-89	1.GND	2.IN	3.OUT
I : SOT-89	1.OUT	2.GND	3.IN
Temperature Range			
C : Commercial Standard			
P : Commercial Standard, Lead(Pb) Free and Phosphorous(P) Free Package			
Output Voltage			
15 : 1.5V	27 : 2.7V	39 : 3.9V	
16 : 1.6V	28 : 2.8V	40 : 4.0V	
17 : 1.7V	29 : 2.85V	41 : 4.1V	
18 : 1.8V	30 : 3.0V	42 : 4.2V	
19 : 1.9V	31 : 3.1V	43 : 4.3V	
20 : 2.0V	32 : 3.2V	44 : 4.4V	
21 : 2.1V	33 : 3.3V	45 : 4.5V	
22 : 2.2V	34 : 3.4V	46 : 4.6V	
23 : 2.3V	35 : 3.5V	47 : 4.7V	
24 : 2.4V	36 : 3.6V	48 : 4.8V	
25 : 2.5V	37 : 3.7V	49 : 4.9V	
26 : 2.6V	38 : 3.8V	50 : 5.0V	

Note: Mask option output types are available by order only

5. Pin Configurations

Part No.	Pin 1	Pin 2	Pin 3
FS8853-xxxE	GND	IN	OUT

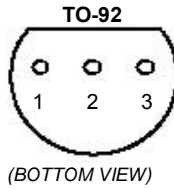

Part No.	Pin 1	Pin 2	Pin 3
FS8853-xxxL	GND	IN	OUT
FS8853-xxxI	OUT	GND	IN

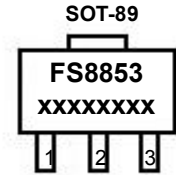

Part No.	Pin 1	Pin 2	Pin 3
FS8853-xxxA	IN	GND	OUT
FS8853-xxxB	GND	IN	OUT
FS8853-xxxC	GND	OUT	IN

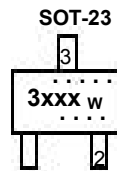

6. Package Marking Information

SOT-23	TO-92 & SOT-89
<p>EX : FS8853-33CC</p> <p>Top Point : Lot No. Bottom Point : Year w : week, A~Z & A ~ Z</p>	<p>EX : FS8853-33CL</p> <p>xxxx : Date Code</p>
<p>EX : FS8853-33PC</p> <p>Top Point : Lot No. Bottom Point : Year w : week, A~Z & A ~ Z A dot after marking : Pb/P Free</p>	<p>EX : FS8853-33PL</p> <p>xxxx : Date Code</p>

7. Pin Description

Part NO.	Symbol	Description
FS8853-xxxA FS8853-xxxB FS8853-xxxC FS8853-xxxE FS8853-xxxL FS8853-xxxI	GND	Ground pin that provides the reference for all voltages.
	IN	Regulator input pin. Supply voltage can range from 2.5V to 9.0V. Bypass with a 1 μ F capacitor to GND.
	OUT	Regulator output pin. Sources up to 300mA. Bypass with a 3.3 μ F capacitor to GND.

8. Functional Block Diagram

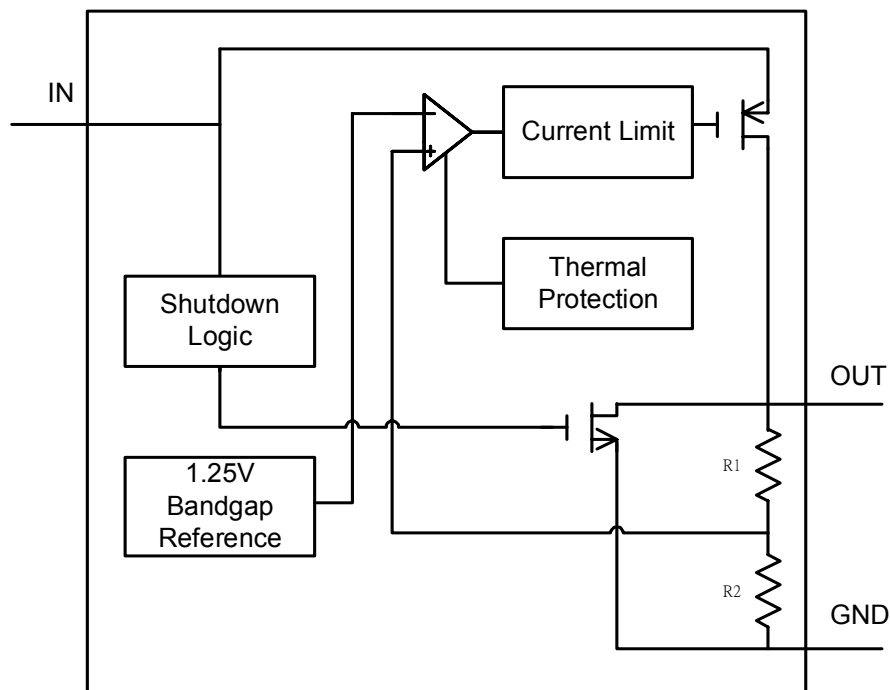

9. Typical Application Circuit

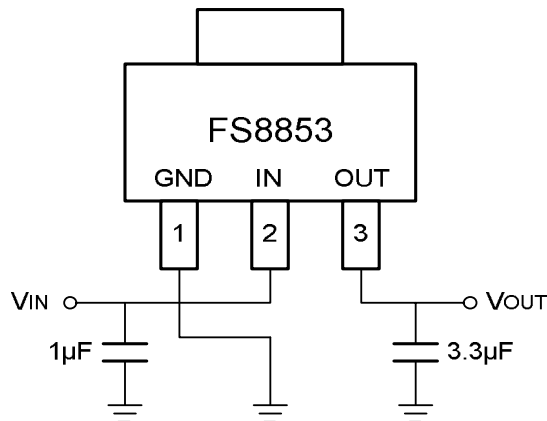

10. Absolute Maximum Ratings

Input voltage VIN to GND	-----	10V
Output current limit, I(LIMIT)	-----	0.6A
Continuous power dissipation, PD ($\Delta T = T_J - T_A = 100^\circ\text{C}$)		
SOT-23	-----	0.30W
SOT-89	-----	0.55W
TO-92	-----	0.55W

* The power dissipation values are based on the condition that junction temperature T_J and ambient temperature T_A difference is 100°C .

Junction Temperature, T_J	-----	$+155^\circ\text{C}$
Storage temperature range, TSTG	-----	-55°C to $+150^\circ\text{C}$
Operating junction temperature range	-----	-40°C to $+125^\circ\text{C}$
Lead temperature (soldering, 10sec)	-----	260°C

Stresses beyond those listed under “absolute maximum ratings” may cause permanent damage to the device. These are stress ratings only, and function operation of the device at these or any other conditions beyond those indicated under “recommended operating conditions” is not implied. Exposure to absolute-maximum-rated conditions for extended periods may affect device reliability.

11. Electrical Characteristics

($T_A=25^{\circ}\text{C}$, unless otherwise noted.)

Symbol	Parameter	Test Conditions	Min	Typ	Max	Unit
VIN	Input Voltage		2.5		9.0	V
VOUT	Output Voltage	VIN=VOUT+0.48V, IOU=1mA, VIN \leq 7V	VOUT-0.035	VOUT	VOUT+0.035	V
		VIN=VOUT+0.48V, IOU=1mA, 7V<VIN \leq 9V	VOUT-0.042	VOUT	VOUT+0.042	V
Δ VOUT	Output Voltage Accuracy	VIN>VOUT+0.48V, VIN \leq 7V	-35		+35	mV
		VIN>VOUT+0.48V, 7V<VIN \leq 9V	-42		+42	mV
IMAX	Maximum Load Current		300			mA
ILIMIT	Current Limit				0.6	A
ISC	Short-Circuit Current	VOUT=0V, VIN=5.0V		300	350	mA
IQ	Ground Pin Current	IOU=0mA to 300mA, VIN=5.0V		30	50	μ A
VDROP	Dropout Voltage	IOU=1mA		1.1	1.3	mV
		IOU=100mA		120	145	mV
		IOU=300mA		400	480	mV
Δ VLINE	Line Regulation	VOUT+0.48V<VIN<9V, IOU=1mA		0.2	0.3	%/V
Δ VLOAD	Load Regulation	IOU=0mA to 300mA		0.01	0.02	%/mA
eN	Output Noise	F=1Hz to 10KHz, COU=3.3 μ F, IOU=0mA		70		μ VRMS
PSRR	Ripple Rejection	F=1KHz, COU=3.3 μ F		70		dB
TSD	Thermal Shutdown Temperature			155		$^{\circ}$ C
THYS	Thermal Shutdown Hysteresis			10		$^{\circ}$ C
θ JA	Thermal Resistance	SOT-23			320	$^{\circ}$ C/W
		SOT-89			180	$^{\circ}$ C/W
		TO-92			180	$^{\circ}$ C/W

12. Typical Operating Characteristics

(VIN=5.0V, CIN=1μF, COUT=3.3μF, TA=+25°C, FS8853-33PL tested, unless otherwise noted.)

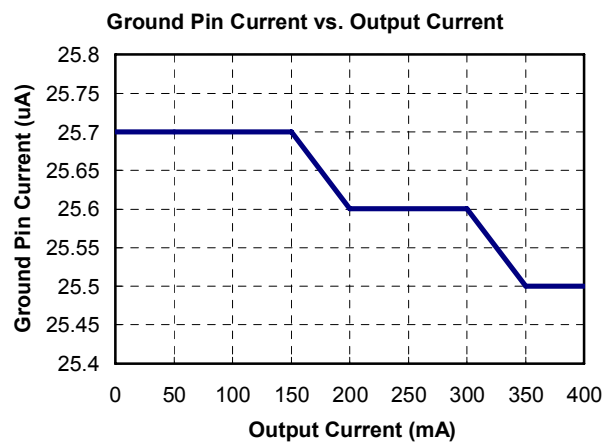
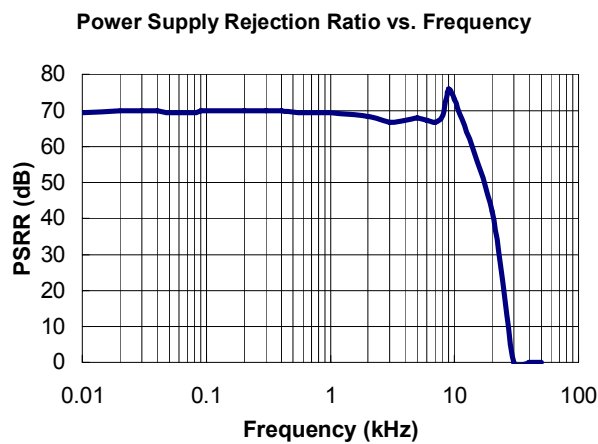
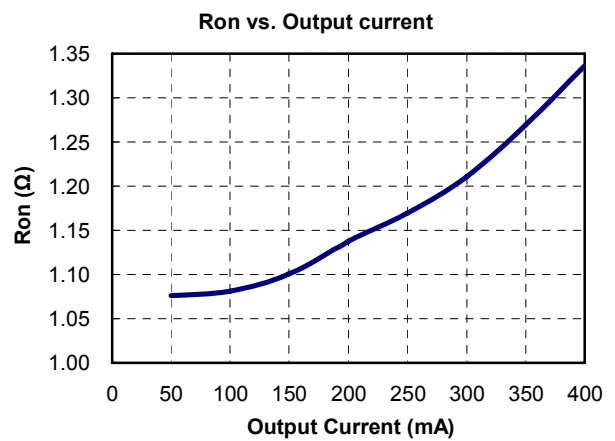
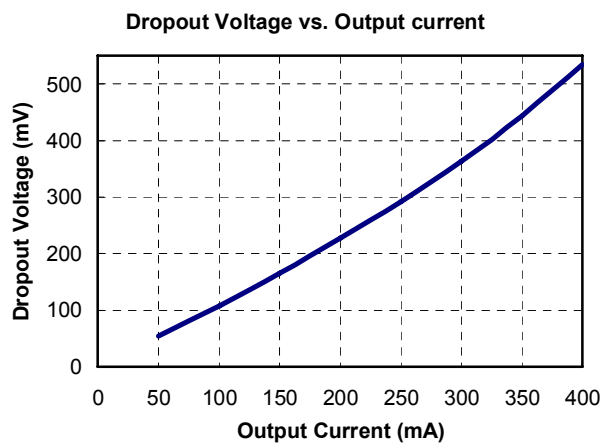
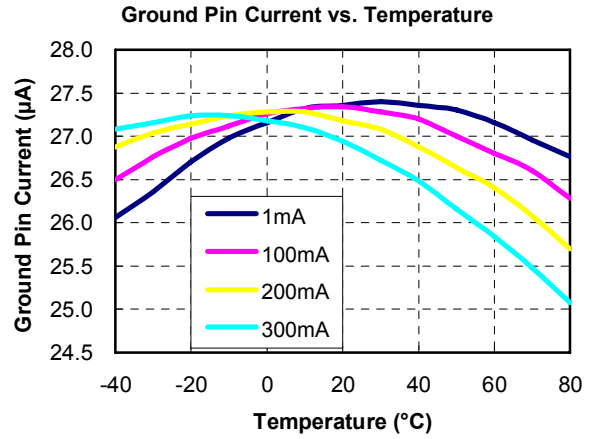
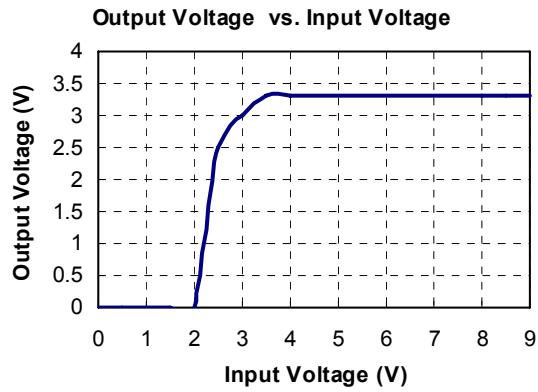

Output Voltage vs. Temperature

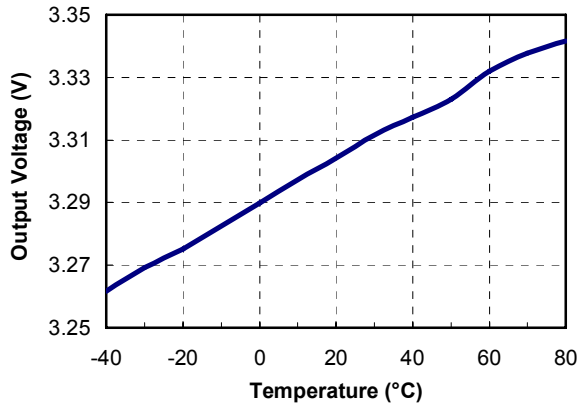

Ground Pin Current vs. Input Voltage

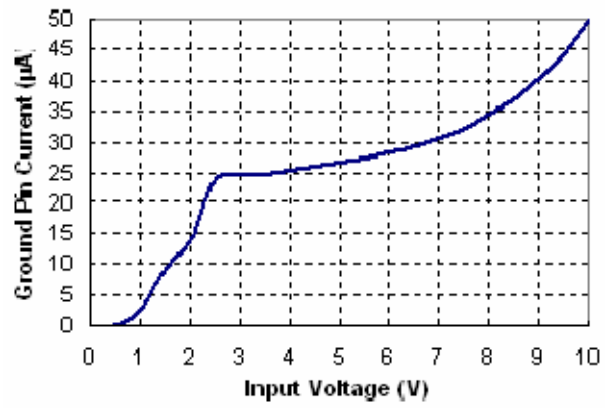

Output Noise DC to 1MHz (60.9µVRMS), I_{OUT}=0mA

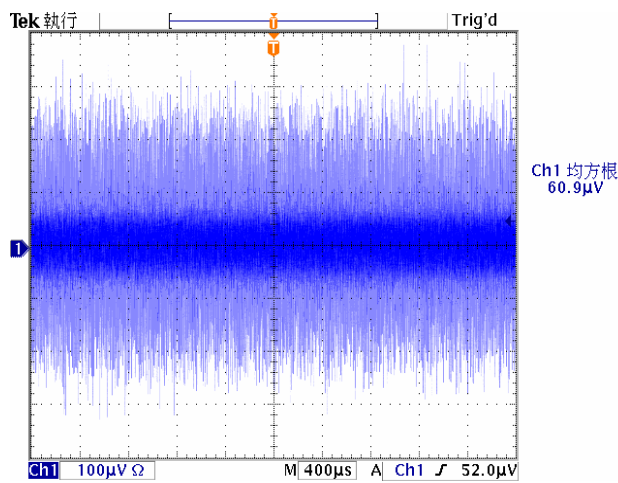

Output Noise DC to 1MHz (371µVRMS), I_{OUT}=300mA

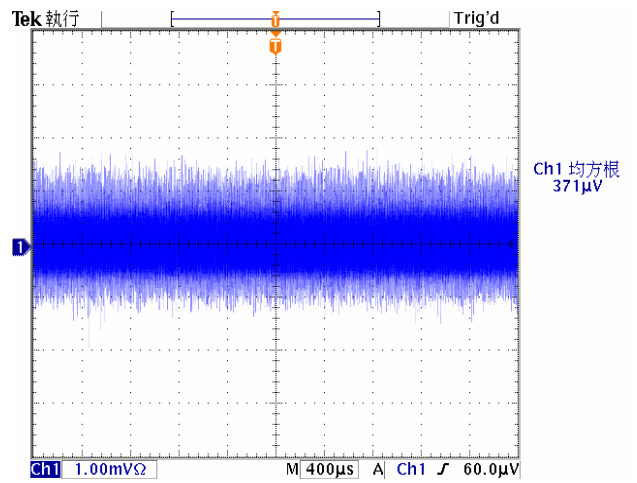

Line Transient (I_{OUT}=1mA, V_{IN}=4V-5V)

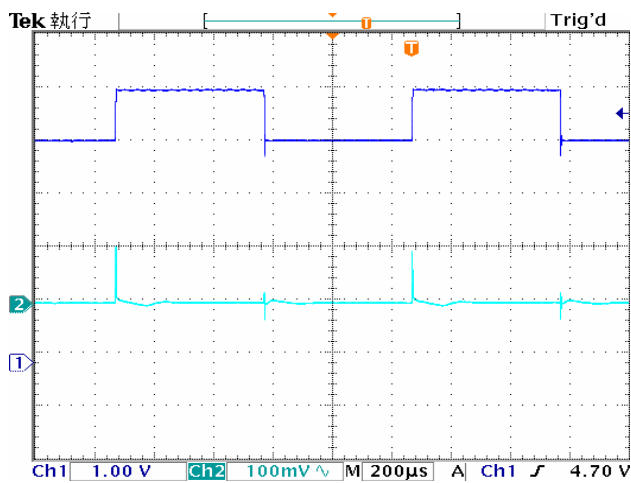

Line Transient (I_{OUT}=10mA, V_{IN}=4V-5V)

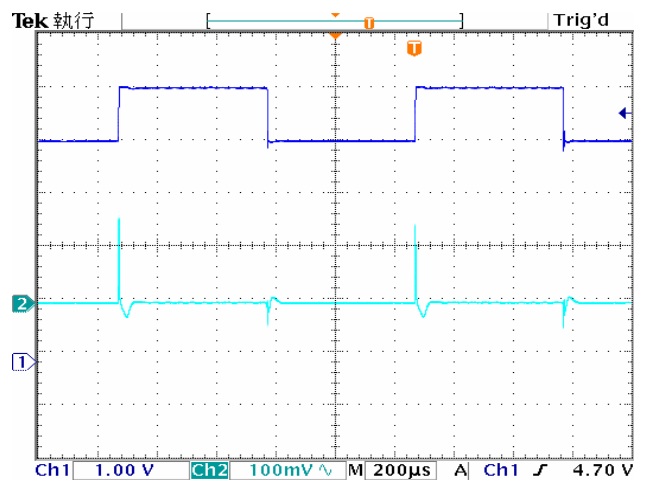

Line Transient (I_{OUT}=100mA, V_{IN}=4V-5V)

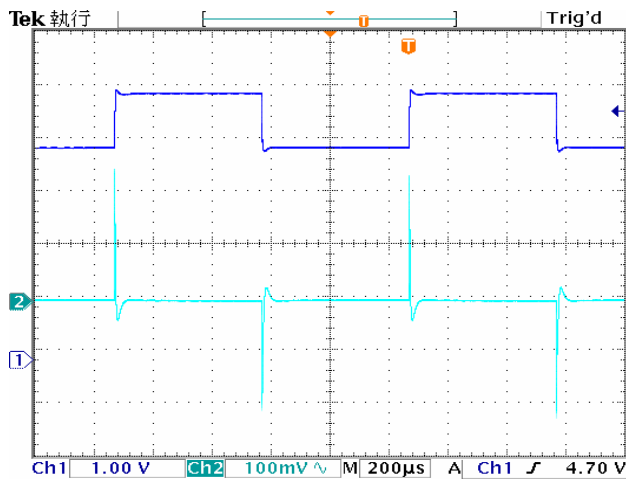

Line Transient (I_{OUT}=200mA, V_{IN}=4V-5V)

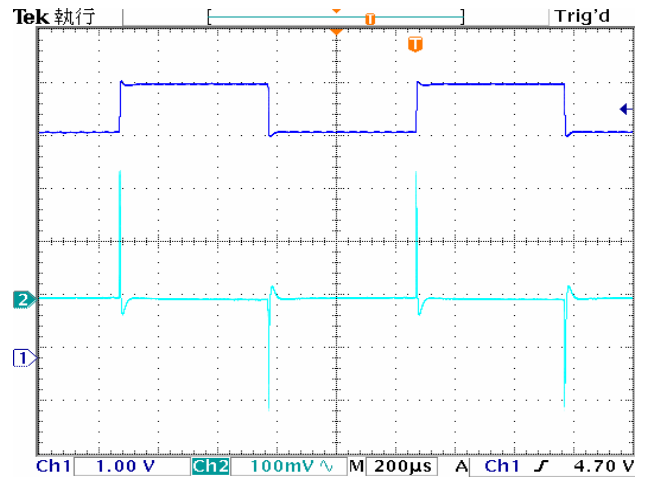

Load Transient (I_{OUT}=1mA-100mA)

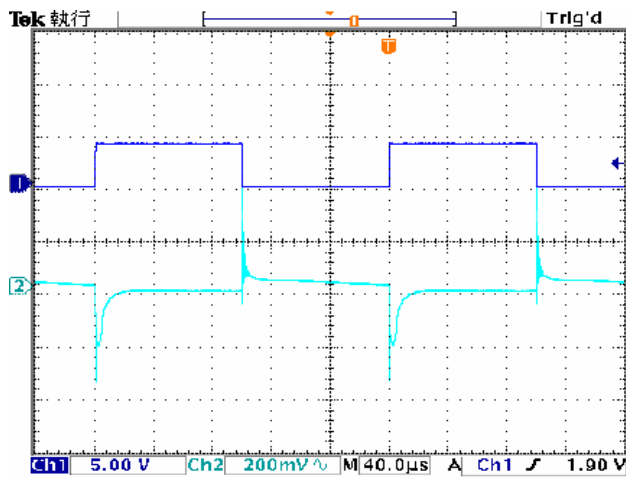

Load Transient (I_{OUT}=100mA-200mA)

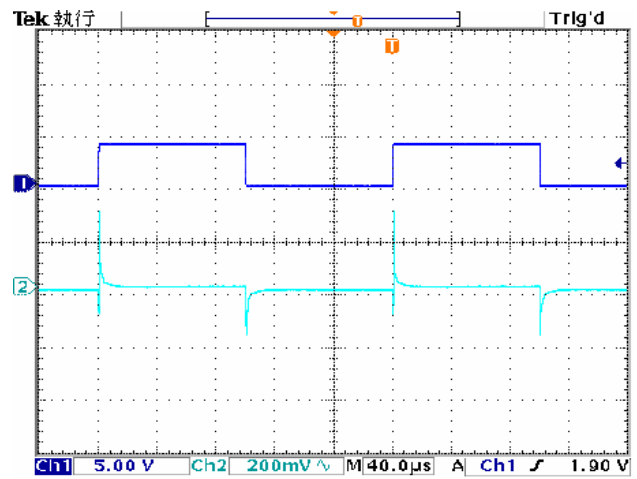

Load Transient (I_{OUT}=200mA-300mA)

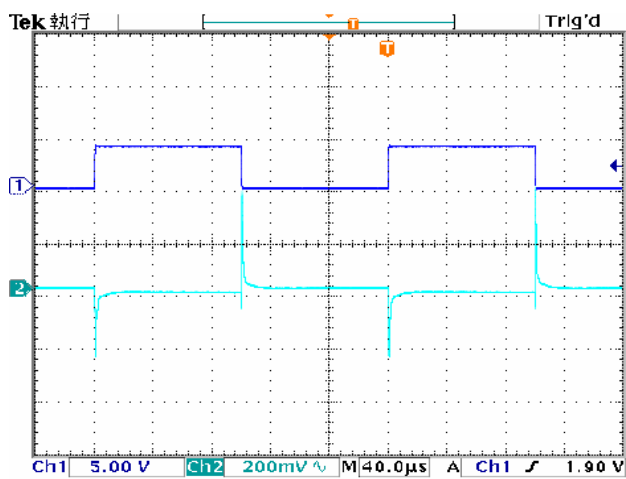

Load Transient (I_{OUT}=1mA-300mA)

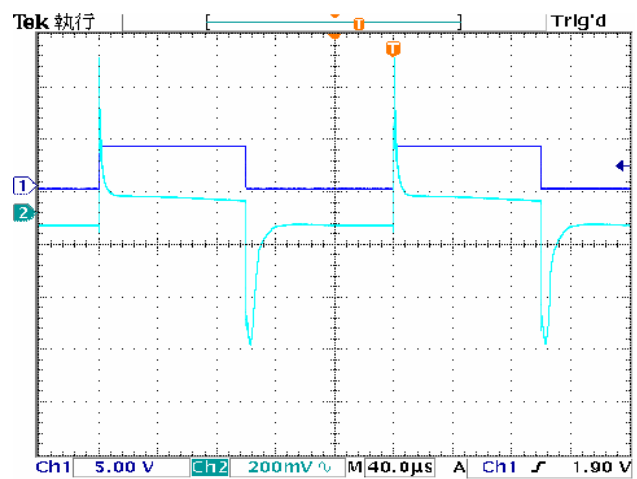

13. Detail Description

The FS8853 is a low-dropout linear regulator. The device provides preset 2.5V and 3.3V output voltages for output current up to 300mA. Other mask options for special output voltages from 1.5V to 5.0V with 100mV increment are also available. As illustrated in function block diagram, it consists of a 1.25V reference, error amplifier, P-channel pass transistor and an internal feedback voltage divider.

The 1.25V bandgap reference is connected to the error amplifier, which compares this reference with the feedback voltage and amplifies the voltage difference. If the feedback voltage is lower than the reference voltage, the pass-transistor gate is pulled lower, which allows more current to pass to the output pin and increases the output voltage. If the feedback voltage is too high, the pass-transistor gate is pulled up to decrease the output voltage.

The output voltage is feedback through an internal resistive divider connected to OUT pin. Additional blocks include an output current limiter, thermal sensor, and shutdown logic.

13.1 Internal P-channel Pass Transistor

The FS8853 features a P-channel MOSFET pass transistor. Unlike similar designs using PNP pass transistors, P-channel MOSFETs require no base drive, which reduces ground pin current. PNP-based regulators also waste considerable current in dropout when the pass transistor saturates, and use high base-drive currents under large loads. The FS8853 does not suffer from these problems and consumes only 30µA (Typ.) of ground pin current under heavy loads as well as in dropout conditions.

13.2 Output Voltage Selection

The FS8853 output voltage is preset at an internally trimmed voltage 2.5V, 3.3V or can be mask-optioned from 1.5V to 5.0V with 100mV increment. The first two digits of part number suffix identify the output voltage (see Ordering Information). For example, the FS8853-33CL has a preset 3.3V output voltage.

13.3 Current Limit

The FS8853 also include a fold back current limiter. It monitors and controls the pass transistor’s gate voltage, estimates the output current, and limits the output current within 0.6A.

13.4 Thermal Overload Protection

Thermal overload protection limits total power dissipation in the FS8853. When the junction temperature exceeds TJ = +155°C, a thermal sensor turns off the pass transistor, allowing the IC to cool down. The thermal sensor turns the pass transistor on again after the junction temperature cools down by 20°C, resulting in a pulsed output during continuous thermal overload conditions.

Thermal overload protection is designed to protect the FS8853 in the event of fault conditions. For continuous operation, the maximum operating junction temperature rating of TJ = +125°C should not be exceeded.

13.5 Operating Region and Power Dissipation

Maximum power dissipation of the FS8853 depends on the thermal resistance of the case and circuit board, the temperature difference between the die junction and ambient air, and the rate of airflow. The power dissipation across the devices is P = IOUT x (VIN-VOUT). The resulting maximum power dissipation is:

$$P_{MAX} = \frac{(T_J - T_A)}{\theta_{JC} + \theta_{CA}} = \frac{(T_J - T_A)}{\theta_{JA}}$$

Where (TJ-TA) is the temperature difference between the FS8853 die junction and the surrounding air, θJC is the thermal resistance of the package chosen, and θCA is the thermal resistance through the printed circuit board, copper traces and other materials to the surrounding air. For better heat-sinking, the copper area should be equally shared between the IN, OUT, and GND pins.

If the FS8853 uses a SOT-89 package and this package is mounted on a double sided printed circuit board with two square inches of copper allocated for “heat spreading”, the resulting θ_{JA} is 180 °C/W.

Based on a maximum operating junction temperature 125 °C with an ambient of 25°C, the maximum power dissipation will be:

$$P_{MAX} = \frac{(T_J - T_A)}{\theta_{JC} + \theta_{CA}} = \frac{(125 - 25)}{180} = 0.555W$$

Thermal characteristics were measured using a double sided board with 1” x 2” square inches of copper area connected to the GND pin for “heat spreading”.

13.6 Input-Output Voltage

A regulator’s minimum input-output voltage differential, or dropout voltage, determines the lowest usable supply voltage. In battery-powered systems, this will determine the useful end-of-life battery voltage. The FS8853 uses a P-channel MOSFET pass transistor, its dropout voltage is a function of drain-to-source on-resistance (RDS(ON)) multiplied by the load current.

$$VDROPOUT = V_{IN} - V_{OUT} = R_{DS(ON)} \times I_{OUT}$$

14. Package Outline

14.1 SOT-23

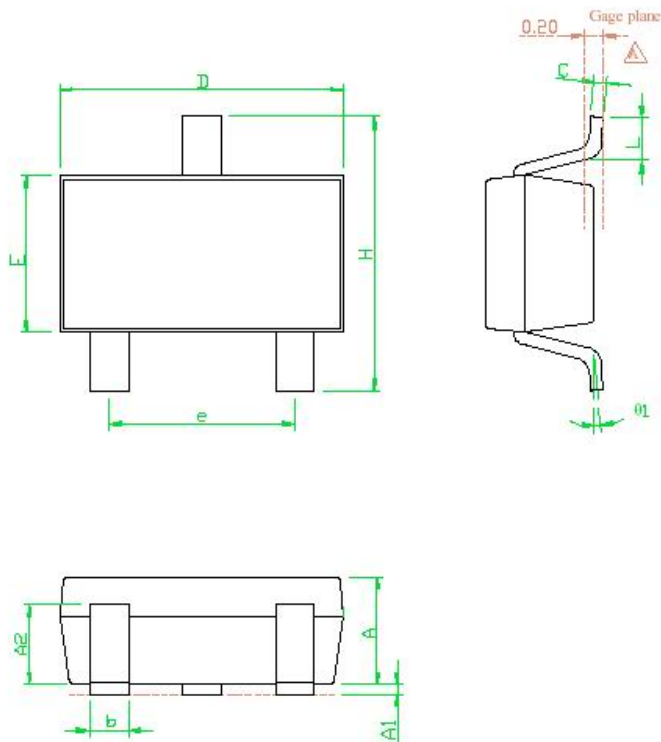

- NOTE
1. PACKAGE BODY SIZES EXCLUDE MOLD FLASH PROTRUSIONS OR GATE BURRS
 2. TOLERANCE ± 0.1000 mm (4 mil) UNLESS OTHERWISE SPECIFIED
 3. COPLANARITY : 0.1000 mm
 4. DIMENSION L IS MEASURED IN GAGE PLANE

SYMBOLS	DIMENSIONS IN MILLIMETERS		
	MIN	NOM	MAX
A	1.00	1.10	1.30
A1	0.00	---	0.10
A2	0.70	0.80	0.90
b	0.35	0.40	0.50
C	0.10	0.15	0.25
D	2.70	2.90	3.10
E	1.40	1.60	1.80
e	---	1.90(TYP)	---
H	2.60	2.80	3.00
L	0.37	---	---
θ1	1°	5°	9°

14.2 SOT-89

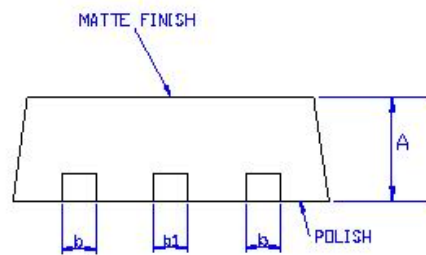
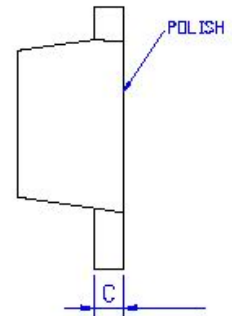
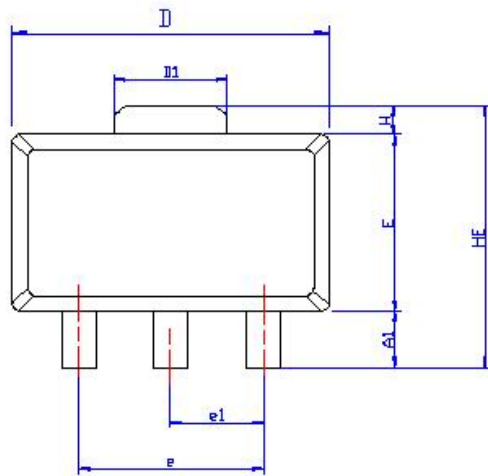

SYMBOLS	DIMENSIONS IN MILLIMETERS			DIMENSIONS IN INCHES		
	MIN	NOM	MAX	MIN	NOM	MAX
A	1.40	1.50	1.60	0.055	0.059	0.063
A1	0.90	1.04	—	0.031	0.041	—
b	0.36	0.42	0.48	0.014	0.016	0.018
b1	0.41	0.47	0.53	0.016	0.018	0.020
C	0.38	0.40	0.43	0.014	0.015	0.017
D	4.40	4.50	4.60	0.173	0.177	0.181
D1	1.40	1.60	1.75	0.055	0.062	0.069
HE	—	—	4.25	—	—	0.167
E	2.40	2.50	2.60	0.094	0.098	0.102
e	2.90	3.00	3.10	0.114	0.118	0.122
H	0.35	0.40	0.45	0.014	0.016	0.018
s	0.65	0.75	0.85	0.026	0.030	0.034
e1	1.40	1.50	1.60	0.054	0.059	0.063

14.3 TO-92

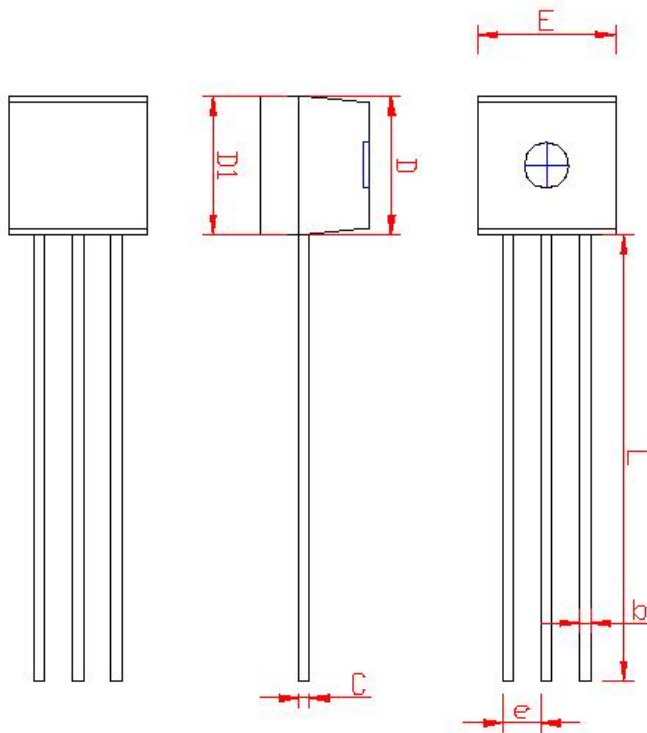

SYMBOL	MILLIMETERS		INCHES	
	MIN.	MAX.	MIN.	MAX.
	A	3.35	3.86	0.132
A1	1.0414	1.55	0.041	0.061
b	0.254	0.508	0.010	0.020
E	4.34	4.85	0.171	0.191
C	0.254	0.508	0.010	0.020
L	14.53	15.04	0.572	0.592
e	1.143	1.397	0.045	0.055
G	3.683	4.191	0.145	0.165
D	4.28	4.80	0.169	0.189
D1	4.34	4.85	0.171	0.191

