

DATA SHEET

74LVT16374A

**3.3V LVT 16-bit edge-triggered D-type
flip-flop (3-State)**

Product data
Supersedes data of 1999 Oct 18

2002 Nov 01

3.3V 16-bit edge-triggered D-type flip-flop (3-State)

74LVT16374A

FEATURES

- 16-bit edge-triggered flip-flop
- 3-State buffers
- Output capability: +64 mA/−32 mA
- TTL input and output switching levels
- Input and output interface capability to systems at 5 V supply
- Bus-hold data inputs eliminate the need for external pull-up resistors to hold unused inputs
- Live insertion/extraction permitted
- Power-up reset
- Power-up 3-State
- No bus current loading when output is tied to 5 V bus
- Latch-up protection exceeds 500 mA per JEDEC Std 17
- ESD protection exceeds 2000V per MIL STD 883 Method 3015 and 200V per Machine Model

DESCRIPTION

The 74LVT16374A is a high-performance BiCMOS product designed for V_{CC} operation at 3.3 V.

This device is a 16-bit edge-triggered D-type flip-flop featuring non-inverting 3-State outputs. The device can be used as two 8-bit flip-flops or one 16-bit flip-flop. On the positive transition of the clock (CP), the Q outputs of the flip-flop take on the logic levels set up at the D inputs.

QUICK REFERENCE DATA

SYMBOL	PARAMETER	CONDITIONS $T_{amb} = 25\text{ }^{\circ}\text{C}$	TYPICAL	UNIT
t_{PLH} t_{PHL}	Propagation delay nCP to nQx	$C_L = 50\text{ pF}$; $V_{CC} = 3.3\text{ V}$	2.9	ns
C_{IN}	Input capacitance	$V_I = 0\text{ V}$ or 3.0 V	3	pF
C_{OUT}	Output pin capacitance	Outputs disabled; $V_O = 0\text{ V}$ or 3.0 V	9	pF
I_{CCZ}	Total supply current	Outputs disabled; $V_{CC} = 3.6\text{ V}$	70	μA

ORDERING INFORMATION

Type number	Package			Temperature Range ($^{\circ}\text{C}$)	Version
	Name	Description			
74LVT16374A DL	SSOP48	plastic shrink small outline package; 48 leads; body width 7.5 mm		−40 to +85	SOT370-1
74LVT16374A DGG	TSSOP48	plastic thin shrink small outline package; 48 leads; body width 6.1 mm		−40 to +85	SOT362-1
74LVT16374AEV	VFPGA56	plastic very thin fine-pitch ball grid array package; 56 balls; body 4.5 x 7 x 0.65 mm		−40 to +85	SOT702-1

3.3V 16-bit edge-triggered D-type flip-flop (3-State)

74LVT16374A

LOGIC SYMBOL (SSOP AND TSSOP PACKAGES)

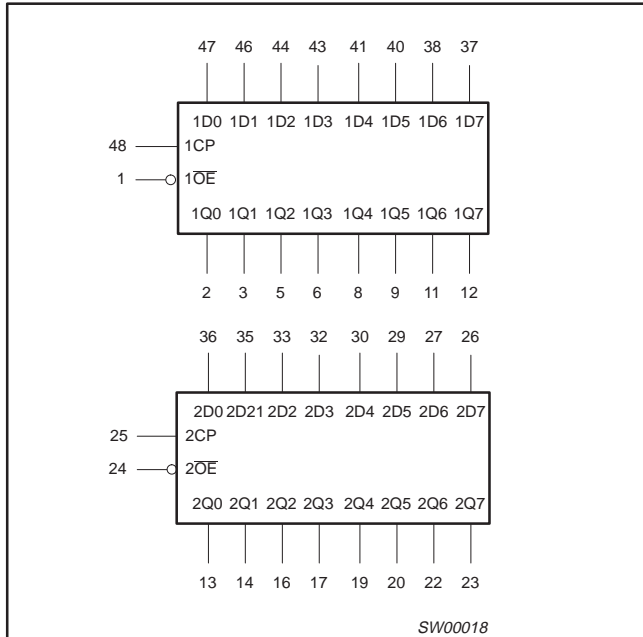

PIN CONFIGURATION (SSOP AND TSSOP PACKAGE OPTIONS)

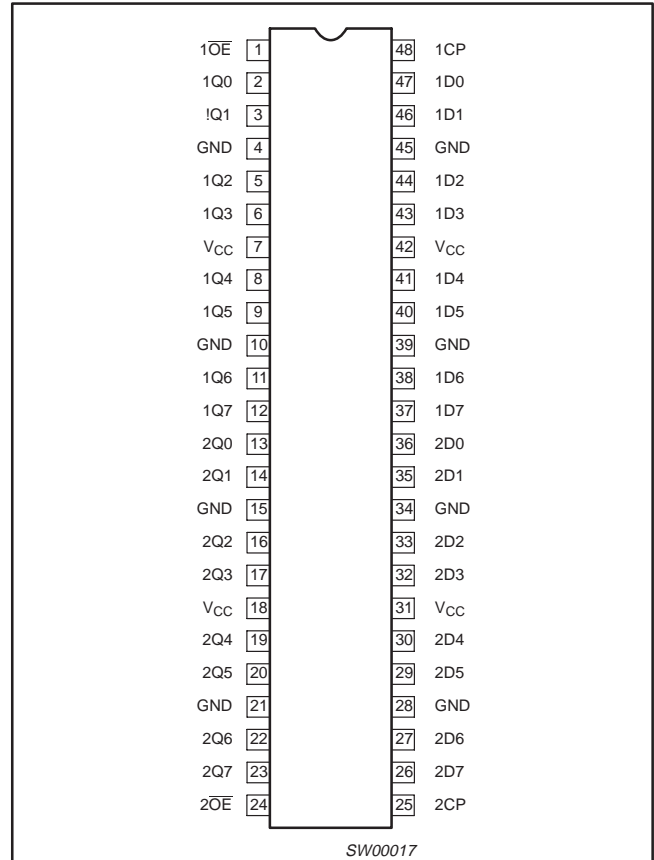

LOGIC SYMBOL (IEEE/IEC)

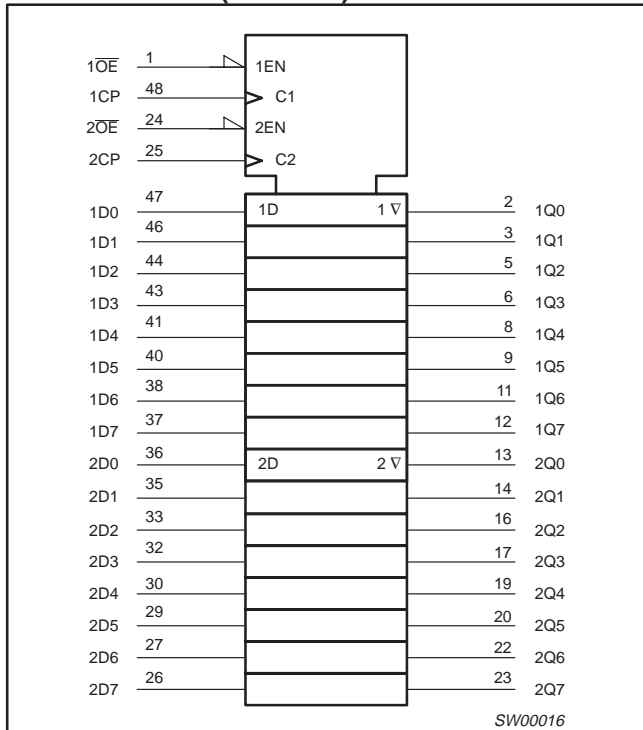

3.3V 16-bit edge-triggered D-type flip-flop (3-State)

74LVT16374A

PIN DESCRIPTION (SSOP AND TSSOP PACKAGE OPTIONS)

PIN NUMBER	SYMBOL	FUNCTION
47, 46, 44, 43, 41, 40, 38, 37, 36, 35, 33, 32, 30, 29, 27, 26	1D0 - 1D7 2D0 - 2D7	Data inputs
2, 3, 5, 6, 8, 9, 11, 12, 13, 14, 16, 17, 19, 20, 22, 23	1Q0 - 1Q7 2Q0 - 2Q7	Data outputs
1, 24	1OE, 2OE	Output enable inputs (active-Low)
48, 25	1CP, 2CP	Clock pulse inputs (active rising edge)
4, 10, 15, 21, 28, 34, 39, 45	GND	Ground (0 V)
7, 18, 31, 42	V _{CC}	Positive supply voltage

EV PACKAGE TERMINAL PLACEMENT, TOP VIEW

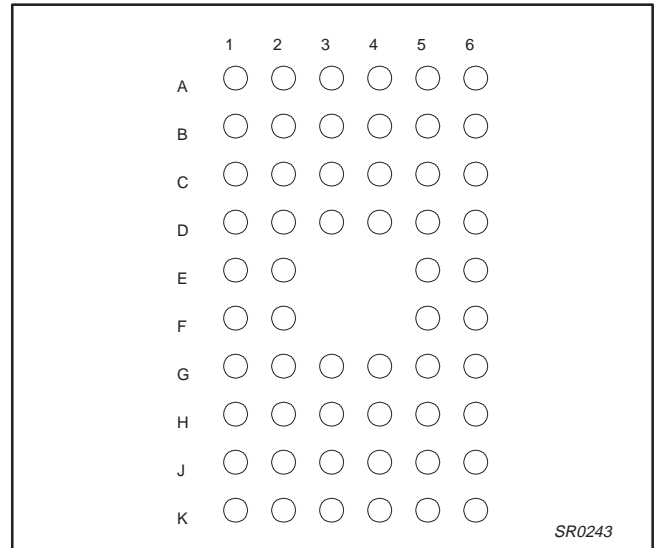

TERMINAL ASSIGNMENTS FOR 74LVT16374A IN VFBGA

	1	2	3	4	5	6
A	1 OEn	NC	NC	NC	NC	1CP
B	1Q1	1Q0	GND	GND	1D0	1D1
C	1Q3	1Q2	V _{CC}	V _{CC}	1D2	1D3
D	1Q5	1Q4	GND	GND	1D4	1D5
E	1Q7	1Q6			1D6	1D7
F	2Q0	2Q1			2D1	2D0
G	2Q2	2Q3	GND	GND	2D3	2D2
H	2Q4	2Q5	V _{CC}	V _{CC}	2D5	2D4
J	2Q6	2Q7	GND	GND	2D7	2D6
K	2OEn	NC	NC	NC	NC	2CP

NOTE:

1. "n" is used to indicate active low in these tables but use standard method in the data sheets

FUNCTION TABLE

INPUTS			INTERNAL REGISTER	OUTPUTS	OPERATING MODE
nOE	nCP	nDx		nQ0 - nQ7	
L L	↑ ↑	l h	L H	L H	Load and read register
L	↑	X	NC	NC	Hold
H H	↑ ↑	X nDx	NC nDx	Z Z	Disable outputs

- H = High voltage level
- h = High voltage level one set-up time prior to the High-to-Low E transition
- L = Low voltage level
- l = Low voltage level one set-up time prior to the High-to-Low E transition
- NC = No change
- X = Don't care
- Z = High impedance "off" state
- ↑ = Low-to-High clock transition
- ↑ = Not a Low-to-High clock transition

3.3V 16-bit edge-triggered D-type flip-flop (3-State)

74LVT16374A

LOGIC DIAGRAM

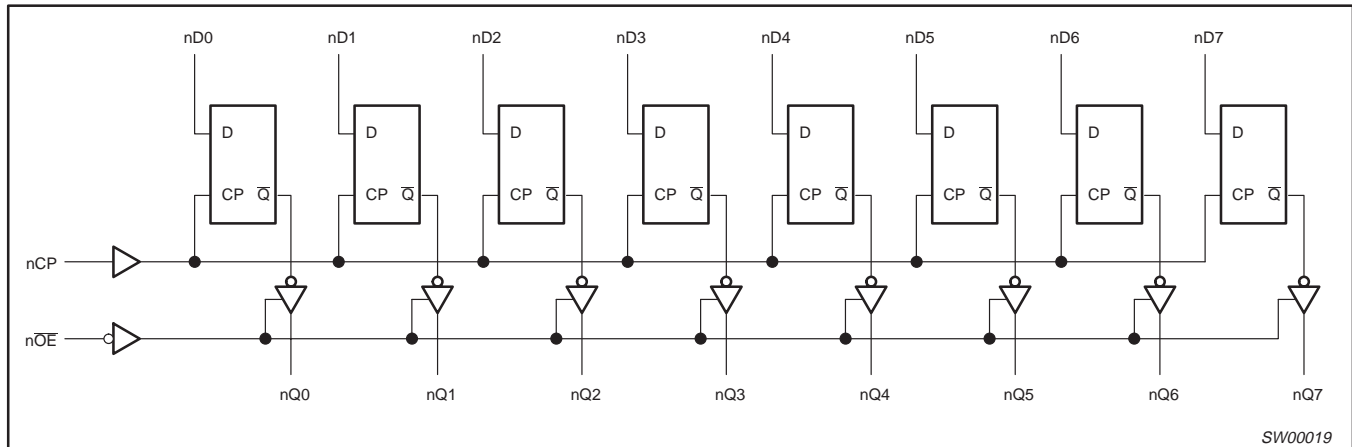

ABSOLUTE MAXIMUM RATINGS^{1, 2}

SYMBOL	PARAMETER	CONDITIONS	RATING	UNIT
V _{CC}	DC supply voltage		-0.5 to +4.6	V
I _{IK}	DC input diode current	V _I < 0	-50	mA
V _I	DC input voltage ³		-0.5 to +7.0	V
I _{OK}	DC output diode current	V _O < 0	-50	mA
V _{OUT}	DC output voltage ³	Output in Off or High state	-0.5 to +7.0	V
I _{OUT}	DC output current	Output in Low state	128	mA
		Output in High state	-64	
T _{stg}	Storage temperature range		-65 to +150	°C

NOTES:

- Stresses beyond those listed may cause permanent damage to the device. These are stress ratings only and functional operation of the device at these or any other conditions beyond those indicated under "recommended operating conditions" is not implied. Exposure to absolute-maximum-rated conditions for extended periods may affect device reliability.
- The performance capability of a high-performance integrated circuit in conjunction with its thermal environment can create junction temperatures which are detrimental to reliability. The maximum junction temperature of this integrated circuit should not exceed 150 °C.
- The input and output negative voltage ratings may be exceeded if the input and output clamp current ratings are observed.

RECOMMENDED OPERATING CONDITIONS

SYMBOL	PARAMETER	LIMITS		UNIT
		MIN	MAX	
V _{CC}	DC supply voltage	2.7	3.6	V
V _I	Input voltage	0	5.5	V
V _{IH}	High-level input voltage	2.0		V
V _{IL}	Input voltage		0.8	V
I _{OH}	High-level output current		-32	mA
I _{OL}	Low-level output current		32	mA
	Low-level output current; current duty cycle ≤ 50%; f ≥ 1kHz		64	
Δt/Δv	Input transition rise or fall rate; Outputs enabled		10	ns/V
T _{amb}	Operating free-air temperature range	-40	+85	°C

3.3V 16-bit edge-triggered D-type flip-flop (3-State)

74LVT16374A

DC ELECTRICAL CHARACTERISTICS

SYMBOL	PARAMETER	TEST CONDITIONS	LIMITS			UNIT	
			Temp = -40 °C to +85 °C				
			MIN	TYP ¹	MAX		
V _{IK}	Input clamp voltage	V _{CC} = 2.7 V; I _{IK} = -18 mA		-0.85	-1.2	V	
V _{OH}	High-level output voltage	V _{CC} = 2.7 to 3.6 V; I _{OH} = -100 μA	V _{CC} -0.2	V _{CC}		V	
		V _{CC} = 2.7 V; I _{OH} = -8 mA	2.4	2.5			
		V _{CC} = 3.0 V; I _{OH} = -32 mA	2.0	2.3			
V _{OL}	Low-level output voltage	V _{CC} = 2.7 V; I _{OL} = 100 μA		0.07	0.2	V	
		V _{CC} = 2.7 V; I _{OL} = 24 mA		0.3	0.5		
		V _{CC} = 3.0 V; I _{OL} = 16 mA		0.25	0.4		
		V _{CC} = 3.0 V; I _{OL} = 32 mA		0.3	0.5		
		V _{CC} = 3.0 V; I _{OL} = 64 mA		0.4	0.55		
V _{RST}	Power-up output Low voltage ⁵	V _{CC} = 3.6 V; I _O = 1 mA; V _I = GND or V _{CC}		0.1	0.55	V	
I _I	Input leakage current	V _{CC} = 3.6 V; V _I = V _{CC} or GND	Control pins		0.1	±1	μA
		V _{CC} = 0 or 3.6 V; V _I = 5.5 V			0.4	10	
		V _{CC} = 3.6 V; V _I = V _{CC}	Data pins ⁴		0.1	1	
		V _{CC} = 3.6 V; V _I = 0			-0.4	-5	
I _{OFF}	Output off current	V _{CC} = 0 V; V _I or V _O = 0 to 4.5 V		0.1	±100	μA	
I _{HOLD}	Bus Hold current D inputs ⁷	V _{CC} = 3 V; V _I = 0.8 V	75	135		μA	
		V _{CC} = 3 V; V _I = 2.0 V	-75	-135			
		V _{CC} = 0 V to 3.6 V; V _{CC} = 3.6 V	±500				
I _{EX}	Current into an output in the High state when V _O > V _{CC}	V _O = 5.5 V; V _{CC} = 3.0 V		50	125	μA	
I _{PU/PD}	Power up/down 3-State output current ³	V _{CC} ≤ 1.2 V; V _O = 0.5 V to V _{CC} ; V _I = GND or V _{CC} ; OE/OE = Don't care		1	±100	μA	
I _{OZH}	3-State output High current	V _{CC} = 3.6 V; V _O = 3.0 V; V _I = V _{IH} or V _{IL}		0.5	5	μA	
I _{OZL}	3-State output Low current	V _{CC} = 3.6 V; V _O = 0.5 V; V _I = V _{IH} or V _{IL}		0.5	-5		
I _{CCH}	Quiescent supply current	V _{CC} = 3.6 V; Outputs High, V _I = GND or V _{CC} , I _O = 0		0.07	0.12	mA	
I _{CCL}		V _{CC} = 3.6 V; Outputs Low, V _I = GND or V _{CC} , I _O = 0		4	6		
I _{CCZ}		V _{CC} = 3.6 V; Outputs Disabled; V _I = GND or V _{CC} , I _O = 0 ⁶		0.07	0.12		
ΔI _{CC}	Additional supply current per input pin ²	V _{CC} = 3 V to 3.6 V; One input at V _{CC} -0.6 V, Other inputs at V _{CC} or GND		0.1	0.2	mA	

NOTES:

- All typical values are at V_{CC} = 3.3 V and T_{amb} = 25 °C.
- This is the increase in supply current for each input at the specified voltage level other than V_{CC} or GND
- This parameter is valid for any V_{CC} between 0 V and 1.2 V with a transition time of up to 10msec. From V_{CC} = 1.2 V to V_{CC} = 3.3 V ± 0.3 V a transition time of 100μsec is permitted. This parameter is valid for T_{amb} = 25 °C only.
- Unused pins at V_{CC} or GND.
- For valid test results, data must not be loaded into the flip-flops (or latches) after applying power.
- I_{CCZ} is measured with outputs pulled to V_{CC} or GND.
- This is the bus hold overdrive current required to force the input to the opposite logic state.

3.3V 16-bit edge-triggered D-type flip-flop (3-State)

74LVT16374A

AC CHARACTERISTICS

GND = 0 V; $t_R = t_F = 2.5$ ns; $C_L = 50$ pF; $R_L = 500$ Ω ; $T_{amb} = -40$ °C to $+85$ °C.

SYMBOL	PARAMETER	WAVEFORM	LIMITS				UNIT
			$V_{CC} = 3.3$ V ± 0.3 V		$V_{CC} = 2.7$ V		
			MIN	TYP ¹	MAX	MAX	
f_{max}	Maximum clock frequency	1	150				MHz
t_{PLH} t_{PHL}	Propagation delay nCP to nQx	1	1.5	2.9	5.0	5.6	ns
t_{PZH} t_{PZL}	Output enable time to High and Low level	3 4	1.5	3.2	4.8	6.0	ns
t_{PHZ} t_{PLZ}	Output disable time from High and Low Level	3 4	1.5	3.9	5.4	6.0	ns
			1.5	3.4	4.6	5.0	

NOTE:

1. All typical values are at $V_{CC} = 3.3$ V and $T_{amb} = 25$ °C.

AC SETUP REQUIREMENTS

GND = 0 V; $t_R = t_F = 2.5$ ns; $C_L = 50$ pF; $R_L = 500$ Ω ; $T_{amb} = -40$ °C to $+85$ °C.

SYMBOL	PARAMETER	WAVEFORM	LIMITS			UNIT
			$V_{CC} = 3.3$ V ± 0.3 V		$V_{CC} = 2.7$ V	
			MIN	TYP	MIN	
$t_{S(H)}$ $t_{S(L)}$	Setup time nDx to nCP	2	2.5	0.7	2.5	ns
$t_{H(H)}$ $t_{H(L)}$	Hold time nDx to nCP	2	0.5	0	0	ns
$t_{W(H)}$ $t_{W(L)}$	nCP pulse width High or Low	1	1.5	0.6	1.5	ns
			3.0	1.6	3.0	

AC WAVEFORMS

$V_M = 1.5$ V, $V_{IN} =$ GND to 3.0 V

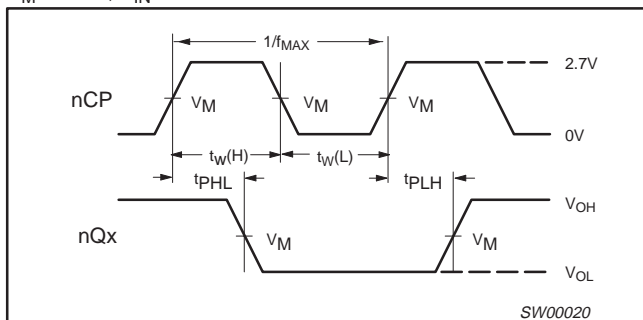

Waveform 1. Propagation Delay, Clock Input to Output, Clock Pulse Width, and Maximum Clock Frequency

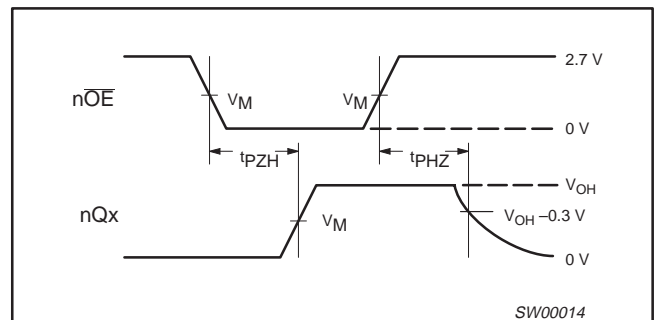

Waveform 3. 3-State Output Enable Time to High Level and Output Disable Time from High Level

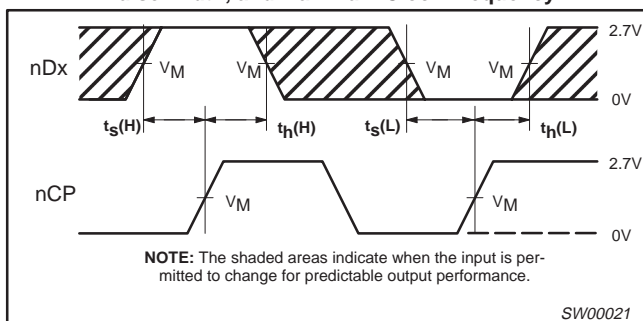

Waveform 2. Data Setup and Hold Times

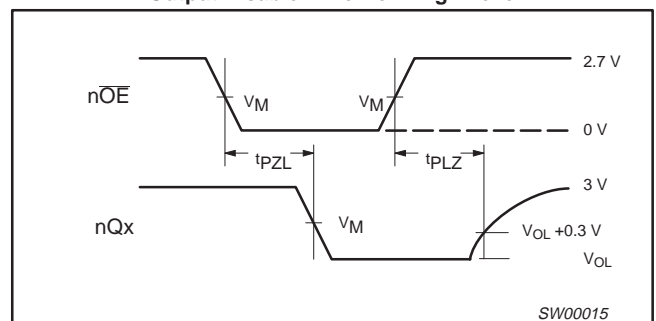

Waveform 4. 3-State Output Enable Time to Low Level and Output Disable Time from Low Level

3.3V 16-bit edge-triggered D-type flip-flop (3-State)

74LVT16374A

TEST CIRCUIT AND WAVEFORMS

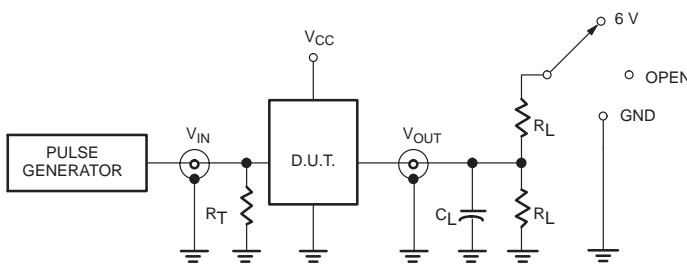

Test Circuit for 3-State Outputs

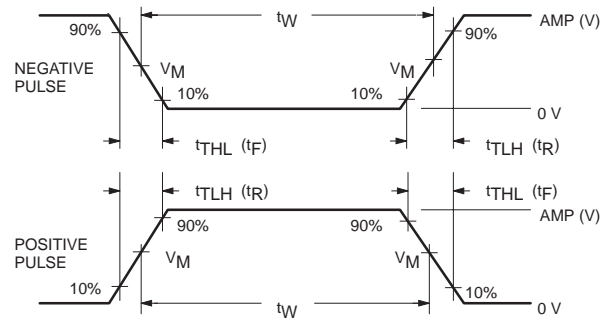

$V_M = 1.5 V$
Input Pulse Definition

SWITCH POSITION

TEST	SWITCH
t_{PHZ}/t_{PZH}	GND
t_{PLZ}/t_{PZL}	6 V
t_{PLH}/t_{PHL}	open

DEFINITIONS

R_L = Load resistor; see AC CHARACTERISTICS for value.

C_L = Load capacitance includes jig and probe capacitance; see AC CHARACTERISTICS for value.

R_T = Termination resistance should be equal to Z_{OUT} of pulse generators.

FAMILY	INPUT PULSE REQUIREMENTS				
	Amplitude	Rep. Rate	t_W	t_R	t_F
74LVT16	2.7 V	≤ 10 MHz	500 ns	≤ 2.5 ns	≤ 2.5 ns

SW00003

3.3V 16-bit edge-triggered D-type flip-flop (3-State)

74LVT16374A

SSOP48: plastic shrink small outline package; 48 leads; body width 7.5 mm

SOT370-1

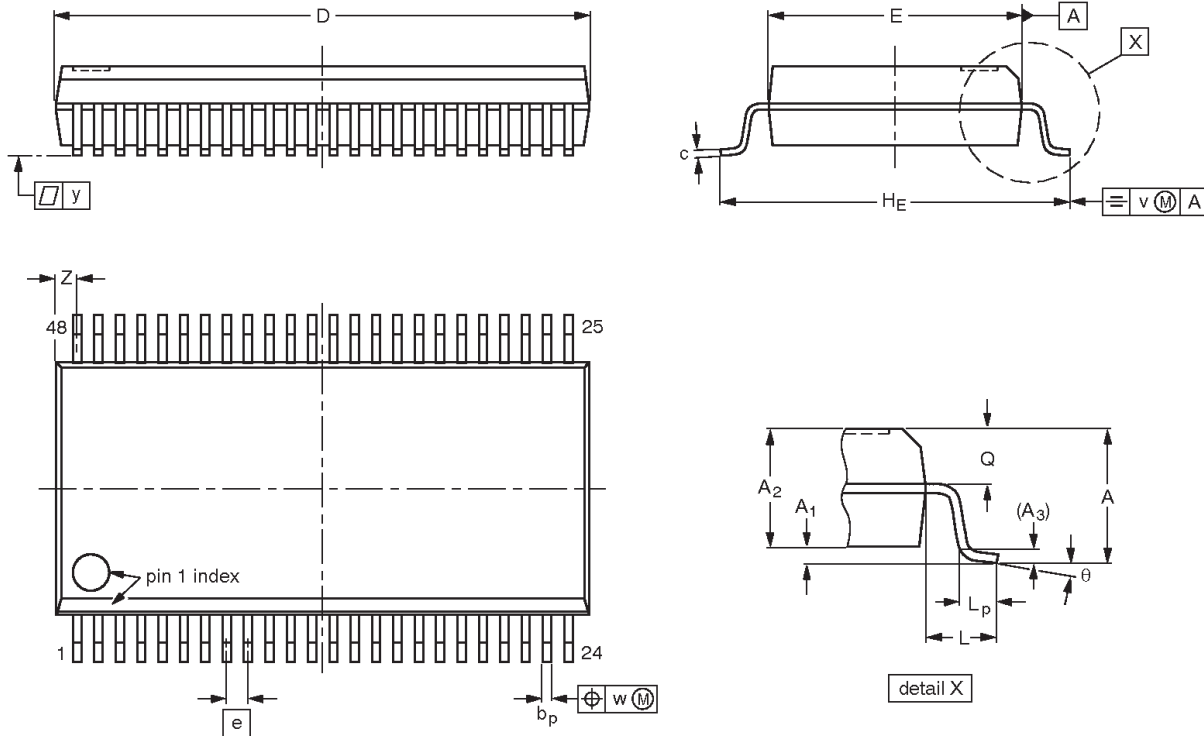

DIMENSIONS (mm are the original dimensions)

UNIT	A max.	A ₁	A ₂	A ₃	b _p	c	D ⁽¹⁾	E ⁽¹⁾	e	H _E	L	L _p	Q	v	w	y	Z ⁽¹⁾	θ
mm	2.8	0.4 0.2	2.35 2.20	0.25	0.3 0.2	0.22 0.13	16.00 15.75	7.6 7.4	0.635	10.4 10.1	1.4	1.0 0.6	1.2 1.0	0.25	0.18	0.1	0.85 0.40	8° 0°

Note

1. Plastic or metal protrusions of 0.25 mm maximum per side are not included.

OUTLINE VERSION	REFERENCES				EUROPEAN PROJECTION	ISSUE DATE
	IEC	JEDEC	EIAJ			
SOT370-1		MO-118				95-02-04 99-12-27

3.3V 16-bit edge-triggered D-type flip-flop (3-State)

74LVT16374A

TSSOP48: plastic thin shrink small outline package; 48 leads; body width 6.1 mm

SOT362-1

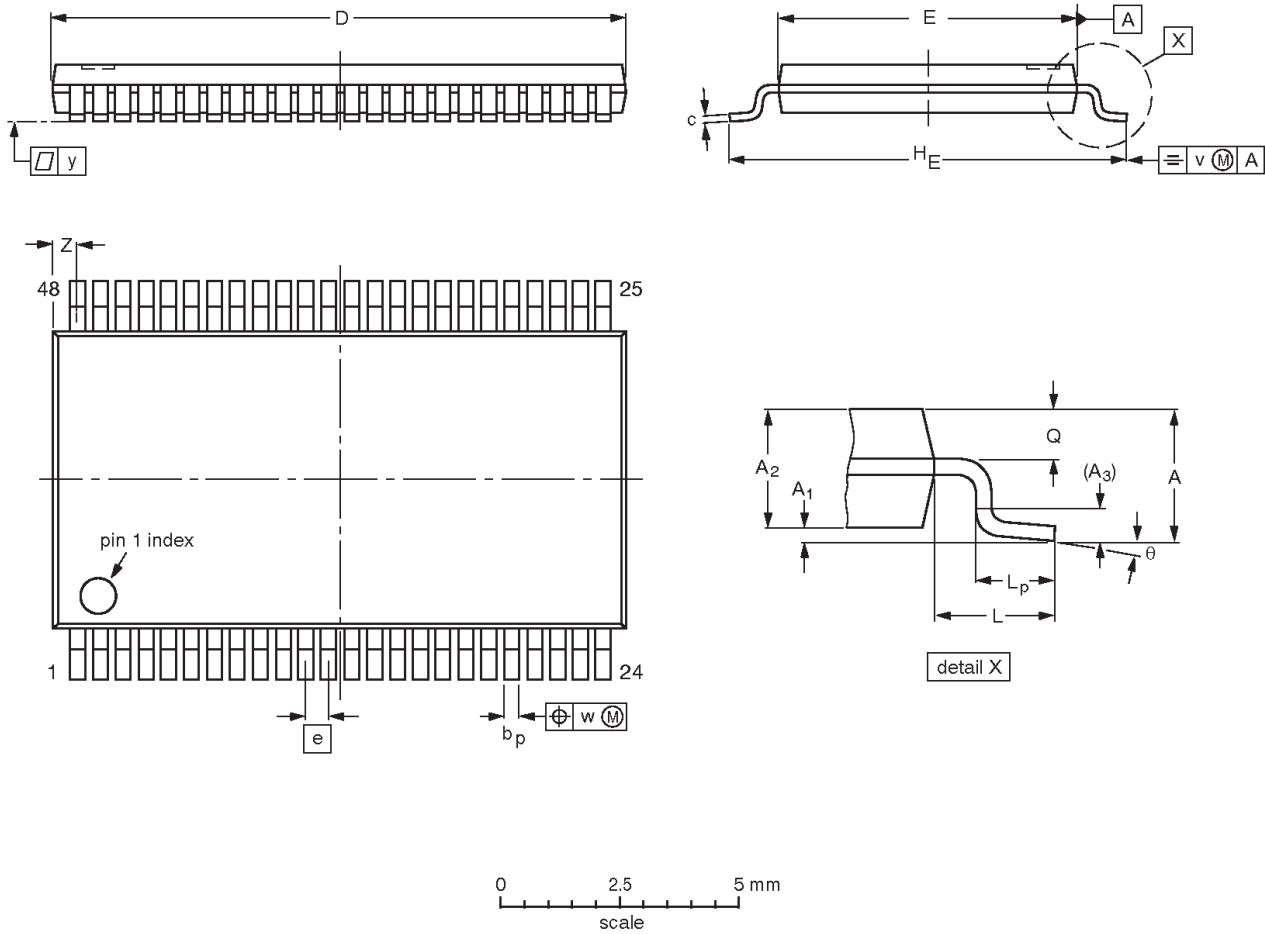

DIMENSIONS (mm are the original dimensions).

UNIT	A max.	A ₁	A ₂	A ₃	b _p	c	D ⁽¹⁾	E ⁽²⁾	e	H _E	L	L _p	Q	v	w	y	Z	θ
mm	1.2	0.15 0.05	1.05 0.85	0.25	0.28 0.17	0.2 0.1	12.6 12.4	6.2 6.0	0.5	8.3 7.9	1	0.8 0.4	0.50 0.35	0.25	0.08	0.1	0.8 0.4	8° 0°

Notes

1. Plastic or metal protrusions of 0.15 mm maximum per side are not included.
2. Plastic interlead protrusions of 0.25 mm maximum per side are not included.

OUTLINE VERSION	REFERENCES				EUROPEAN PROJECTION	ISSUE DATE
	IEC	JEDEC	EIAJ			
SOT362-1		MO-153				-95-02-10 99-12-27

3.3V 16-bit edge-triggered D-type flip-flop (3-State)

74LVT16374A

VFBA56: plastic very thin fine-pitch ball grid array package; 56 balls;
body 4.5 x 7 x 0.65 mm

SOT702-1

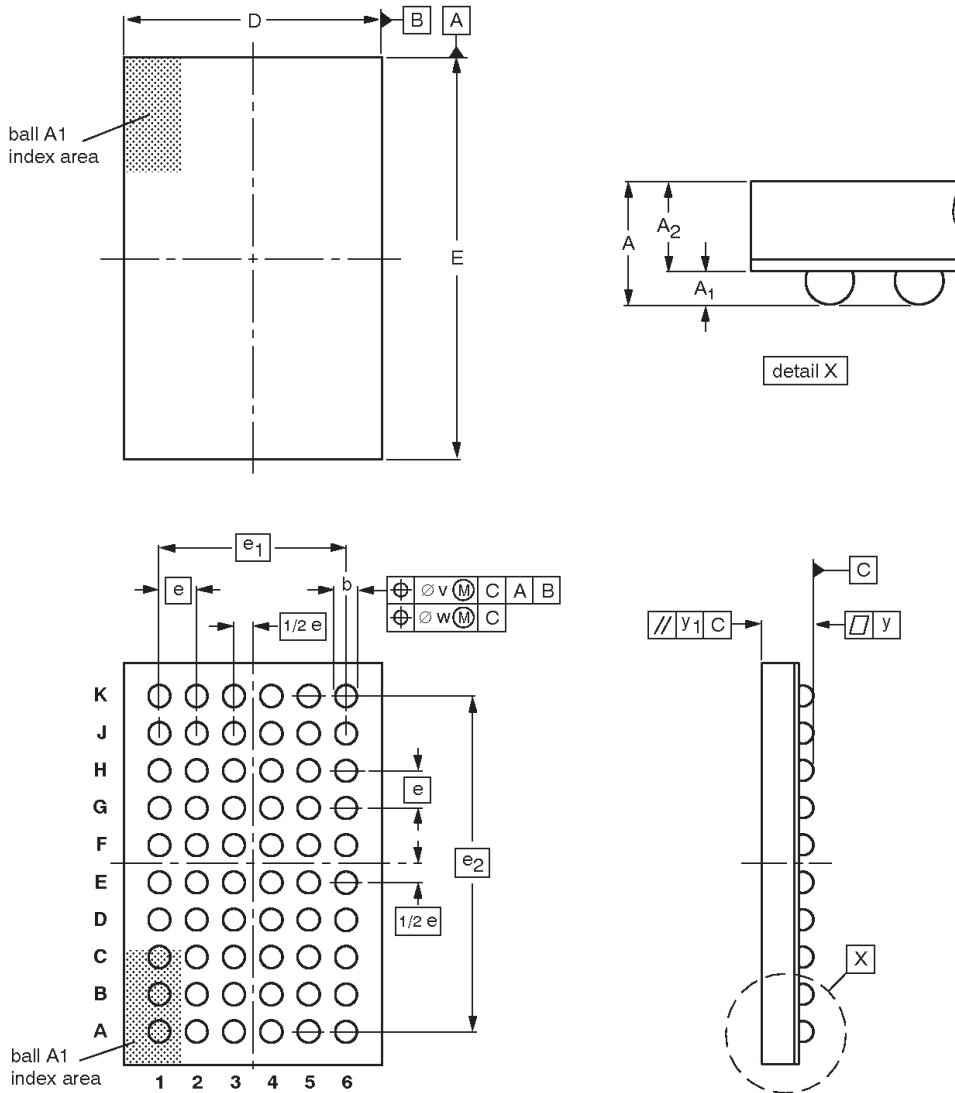

DIMENSIONS (mm are the original dimensions)

UNIT	A _{max.}	A ₁	A ₂	b	D	E	e	e ₁	e ₂	v	w	y	y ₁
mm	1	0.3 0.2	0.7 0.6	0.45 0.35	4.6 4.4	7.1 6.9	0.65	3.25	5.85	0.15	0.08	0.08	0.1

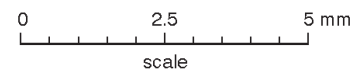

OUTLINE VERSION	REFERENCES				EUROPEAN PROJECTION	ISSUE DATE
	IEC	JEDEC	JEITA			
SOT702-1		MO-225				-01-06-25- 02-08-08

**3.3V 16-bit edge-triggered D-type flip-flop
(3-State)**

74LVT16374A

REVISION HISTORY

Rev	Date	Description
_4	20021101	Product data (9397 750 10649); supersedes Product specification 74LVT16374A_3 of 1999 Oct 18 (9397 750 06514) Engineering Change Notice 853-1781 29140 (date: 20021101) Modifications: <ul style="list-style-type: none">• Added VFBGA package option

3.3V 16-bit edge-triggered D-type flip-flop (3-State)

74LVT16374A

Data sheet status

Level	Data sheet status ^[1]	Product status ^{[2] [3]}	Definitions
I	Objective data	Development	This data sheet contains data from the objective specification for product development. Philips Semiconductors reserves the right to change the specification in any manner without notice.
II	Preliminary data	Qualification	This data sheet contains data from the preliminary specification. Supplementary data will be published at a later date. Philips Semiconductors reserves the right to change the specification without notice, in order to improve the design and supply the best possible product.
III	Product data	Production	This data sheet contains data from the product specification. Philips Semiconductors reserves the right to make changes at any time in order to improve the design, manufacturing and supply. Relevant changes will be communicated via a Customer Product/Process Change Notification (CPCN).

[1] Please consult the most recently issued data sheet before initiating or completing a design.

[2] The product status of the device(s) described in this data sheet may have changed since this data sheet was published. The latest information is available on the Internet at URL <http://www.semiconductors.philips.com>.

[3] For data sheets describing multiple type numbers, the highest-level product status determines the data sheet status.

Definitions

Short-form specification — The data in a short-form specification is extracted from a full data sheet with the same type number and title. For detailed information see the relevant data sheet or data handbook.

Limiting values definition — Limiting values given are in accordance with the Absolute Maximum Rating System (IEC 60134). Stress above one or more of the limiting values may cause permanent damage to the device. These are stress ratings only and operation of the device at these or at any other conditions above those given in the Characteristics sections of the specification is not implied. Exposure to limiting values for extended periods may affect device reliability.

Application information — Applications that are described herein for any of these products are for illustrative purposes only. Philips Semiconductors make no representation or warranty that such applications will be suitable for the specified use without further testing or modification.

Disclaimers

Life support — These products are not designed for use in life support appliances, devices, or systems where malfunction of these products can reasonably be expected to result in personal injury. Philips Semiconductors customers using or selling these products for use in such applications do so at their own risk and agree to fully indemnify Philips Semiconductors for any damages resulting from such application.

Right to make changes — Philips Semiconductors reserves the right to make changes in the products—including circuits, standard cells, and/or software—described or contained herein in order to improve design and/or performance. When the product is in full production (status 'Production'), relevant changes will be communicated via a Customer Product/Process Change Notification (CPCN). Philips Semiconductors assumes no responsibility or liability for the use of any of these products, conveys no license or title under any patent, copyright, or mask work right to these products, and makes no representations or warranties that these products are free from patent, copyright, or mask work right infringement, unless otherwise specified.

Contact information

For additional information please visit
<http://www.semiconductors.philips.com>. Fax: +31 40 27 24825

© Koninklijke Philips Electronics N.V. 2002
All rights reserved. Printed in U.S.A.

Date of release: 11-02

For sales offices addresses send e-mail to:
sales.addresses@www.semiconductors.philips.com

Document order number:

9397 750 10649

Let's make things better.