

HNC Series

2.5mm Pitch Connector for Discrete Wire Connection



Positive-Lock



Low Profile



P=2.5mm

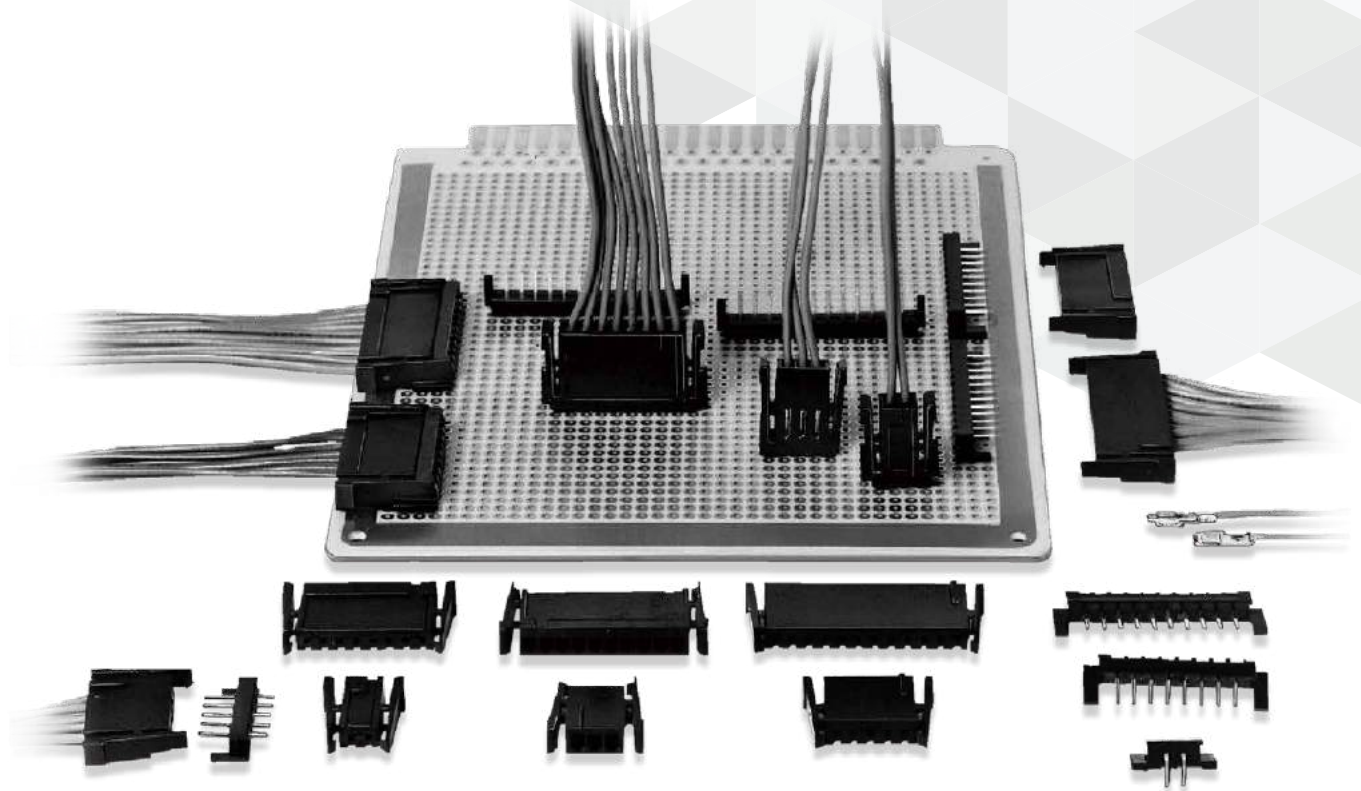

Features

1. Positive Lock

Positive lock design does not unlock without releasing the lock on both sides for effective prevention against cable disconnection when the cable gets caught, etc.

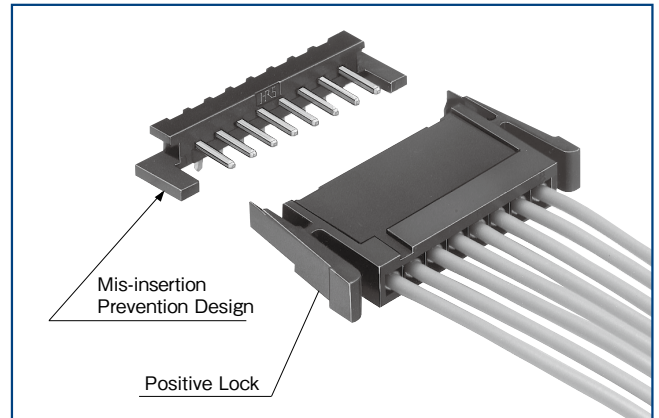

2. Low Profile

Mounted height when the connector is used at a right angle : 4.8mm

3. Mechanism to Prevent Mis-insertion

This thin type connector is equipped with a mis-insertion prevention design.

4. Tin and Gold Plating Variations Available

Two plating types, tin and gold, are available and can be chosen based on your application needs. Additionally, the tin plating type has a light operating feel.

Applications

Various business equipment, financial terminals

Product Specifications

Rated Current (Note 1)	22 AWG	24AWG	26 AWG	28 AWG	30 AWG	Operating Temperature (Note 2)	-55 to +85°C
	3A/pin	3A/pin	2A/pin	1A/pin	0.5A/pin	Storage Temperature Range	-10 to +60°C
Rated Voltage	250V AC/DC					Operating Humidity Range (Note 3)	20 to 80%
						Storage Humidity Range	40 to 70%

Item	Specification	Condition
Insulation Resistance	1000M Ω Min.	500V DC
Withstanding Voltage	No flashover or insulation breakdown.	1000V AC for 1 min.
Contact Resistance	10m Ω Max.	Measured at a maximum of 20mV, 1mA (DC or 1000Hz)
Insertion/Extraction Force	Insertion force : 4.4N Max. Extraction force : 0.4N Min.	Measure at the square steel pin of 0.635 \pm 0.002mm
Vibration	No electrical discontinuity of 10 μ s or more	10 cycles in each of three axis at frequency 10-55Hz, half amplitude 0.75mm
Humidity (Steady State)	Contact resistance : 10m Ω Max. Insulation resistance : 1000M Ω Min.	96 hours at temperature of 40 \pm 2°C and humidity of 90% to 95%
Temperature Cycle	Contact resistance : 10m Ω Max. Insulation resistance : 1000M Ω Min.	(-55°C : 30 minutes \rightarrow 5 to 35°C : 2 to 3 minutes -85°C : 30 minutes \rightarrow 5 to 35°C : 2 to 3 minutes) 5 cycles
Mating Durability	Tin plating : Contact resistance : 30m Ω Max. Gold plating : Contact resistance : 20m Ω Max.	Tin plating : 30 cycles Gold plating : 50 cycles
Resistance to Soldering Heat	No deformation of components affecting performance.	Flow : 250°C for 5 seconds
		Manual soldering : 300°C for 2 seconds

Note 1 : The rated current varies based on the cable size for use. The rated current of the header only is 3A.

Note 2 : Includes temperature rise caused by current flow.

Note 3 : The connector should be completely dry (no condensation present).

Note 4 : Information contained in this catalog represents general requirements for this Series. Contact us for the drawings and specifications for a specific part number shown.

Materials / Finish

Product	Part	Material	Finish	Remarks	RoHS
Crimp Socket	Insulator	Polyamide	Black	UL94V-2	○
Socket Crimp Contact	Contact	Phosphor Bronze	Tin Plated or Gold Plated	-	
Pin Header	Insulator	Polyamide	Black	UL94V-2	
	Contact	Brass	Tin Plated or Gold Plated	-	

Product Number Structure

Refer to the chart below when determining the product specifications from the product number.
Please select from the product numbers listed in this catalog when placing orders.

■ Connector

HNC2 - 2.5 P - # DSL

① ② ③ ④ ⑤

① Series Name	HNC2, 1	④ Number of Contacts	2 to 5, 7, 8, 10, 12, 15
② Contact Pitch	2.5mm	⑤ Contact Type	None : Crimp Socket DS : Straight DSL : Right Angle
③ Connector Type	S : Socket P : Pin Header		

■ Contact

HNC - 2.5S - C - A

① ② ③

① Type	2.5mm Pitch Socket	③ Applicable Cable Size	A : 22-26 AWG B : 26-30 AWG
② Packaging Type	C : Reel D : Bag		

Crimp Socket

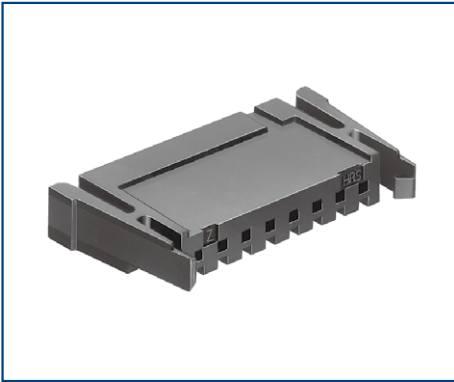

[Fig.1]

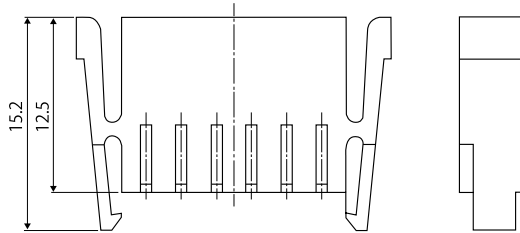
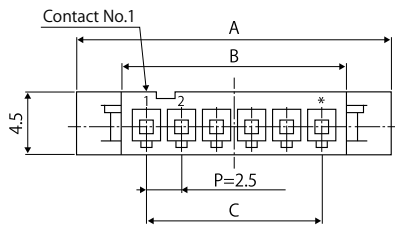

[Fig.2]

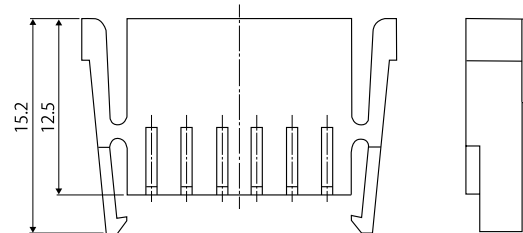
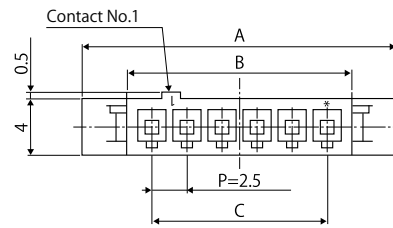

Unit : mm

Part No.	HRS No.	No. of Pos.	A	B	C	Dimensions	Purchase Unit
HNC2-2.5S-2	CL0218-0011-1-00	2	12.4	6.0	2.5	Fig.1	100pcs per bag
HNC2-2.5S-3	CL0218-0022-8-00	3	14.9	8.5	5.0		
HNC2-2.5S-4	CL0218-0039-0-00	4	17.4	11.0	7.5		
HNC2-2.5S-5	CL0218-0027-1-00	5	19.9	13.5	10.0		
HNC2-2.5S-7	CL0218-0030-6-00	7	24.9	18.5	15.0		
HNC2-2.5S-8	CL0218-0014-0-00	8	27.4	21.0	17.5		
HNC2-2.5S-10	CL0218-0017-8-00	10	32.4	26.0	22.5	Fig.2	
HNC1-2.5S-12	CL0218-0008-7-00	12	37.0	31.0	27.5		
HNC2-2.5S-15	CL0218-0045-3-00	15	44.9	38.5	35.0	Fig.1	

Note : The series name for the 12 position connector is HNC1 and varies slightly in design.

Straight Pin Header

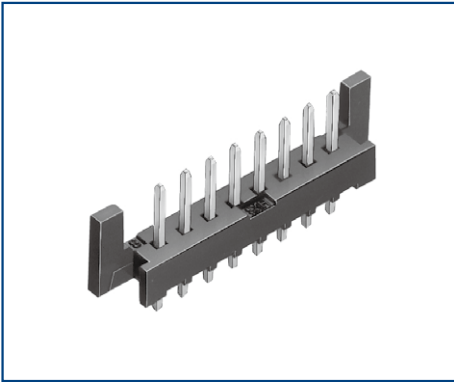

[Fig.3]

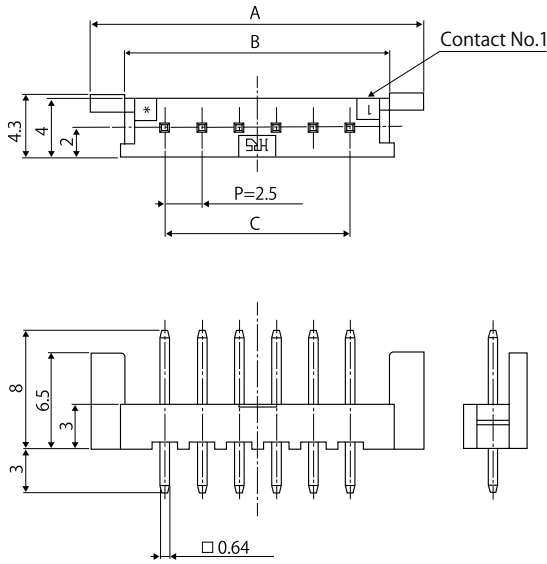

[Fig.4]

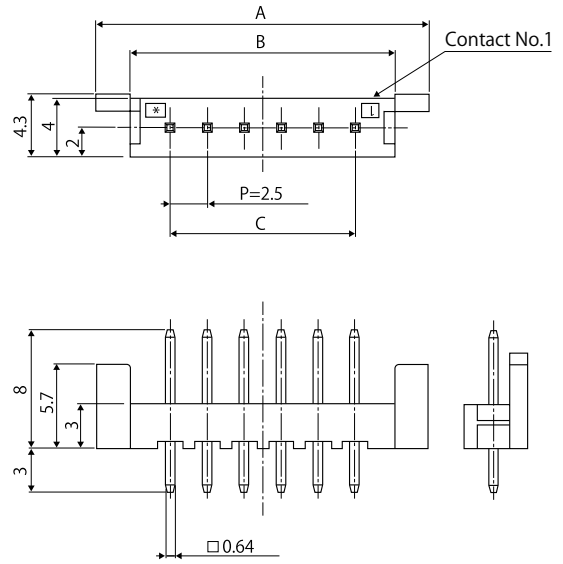

Note : Board Through-hole Diameter : $\phi 1.1 \pm 0.1$

Unit : mm

Part No.	HRS No.	No. of Pos.	A	B	C	Specific No.		Dimensions	Purchase Unit
						Tin Plating	Gold Plating		
HNC2-2.5P-2DS(##)	CL0218-0012-4-##	2	12.5	7.8	2.5	55	02	Fig.3	100pcs per bag
HNC2-2.5P-3DS(##)	CL0218-0023-0-##	3	15.0	10.4	5.0	55	02		
HNC2-2.5P-4DS(##)	CL0218-0040-0-##	4	17.5	12.9	7.5	55	01		
HNC2-2.5P-5DS(##)	CL0218-0028-4-##	5	20.0	15.4	10.0	55	02		
HNC2-2.5P-7DS(##)	CL0218-0031-9-##	7	25.0	20.4	15.0	55	02		
HNC2-2.5P-8DS(##)	CL0218-0015-2-##	8	27.5	22.8	17.5	55	02		
HNC2-2.5P-10DS(##)	CL0218-0018-0-##	10	32.5	27.8	22.5	55	02	Fig.4	
HNC1-2.5P-12DS(##)	CL0218-0009-0-##	12	35.5	32.8	27.5	55	02	Fig.3	
HNC2-2.5P-15DS(##)	CL0218-0046-6-##	15	45.0	40.4	35.0	55	01	Fig.3	

Note : The series name for the 12 position connector is HNC1 and varies slightly in design.

Right Angle Pin Header

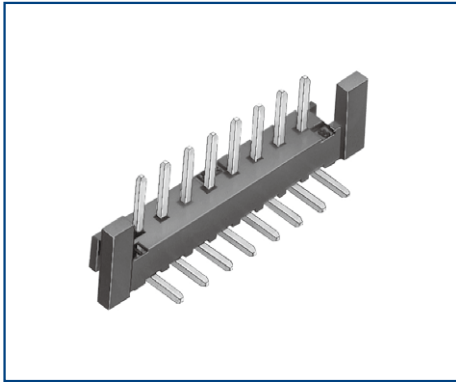

[Fig.5]

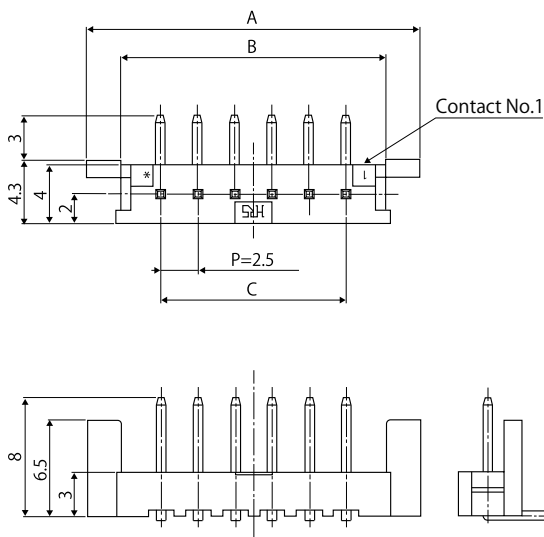

[Fig.6]

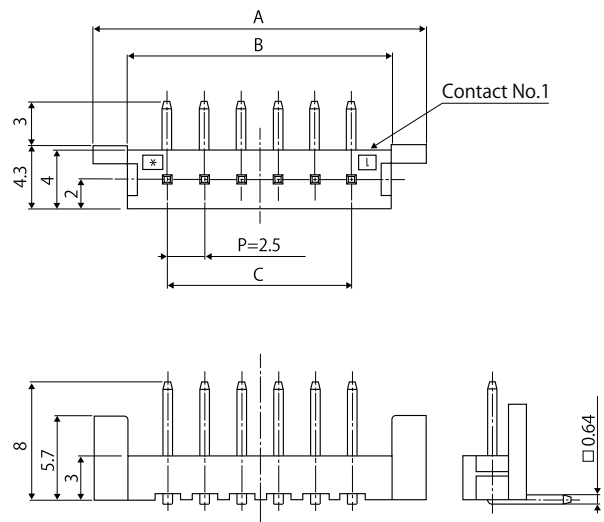

Note : Board Through-hole Diameter : $\phi 1.1^{+0.1}$

Unit : mm

Part No.	HRS No.	No. of Pos.	A	B	C	Specific No.		Dimensions	Purchase Unit
						Tin Plating	Gold Plating		
HNC2-2.5P-2DSL(##)	CL0218-0013-7-##	2	12.5	7.8	2.5	55	02	Fig.5	100pcs per bag
HNC2-2.5P-3DSL(##)	CL0218-0024-3-##	3	15.0	10.4	5.0	55	02		
HNC2-2.5P-4DSL(##)	CL0218-0041-2-##	4	17.5	12.9	7.5	55	01		
HNC2-2.5P-5DSL(##)	CL0218-0029-7-##	5	20.0	15.4	10.0	55	02		
HNC2-2.5P-7DSL(##)	CL0218-0032-1-##	7	25.0	20.4	15.0	55	02		
HNC2-2.5P-8DSL(##)	CL0218-0016-5-##	8	27.5	22.8	17.5	55	02		
HNC2-2.5P-10DSL(##)	CL0218-0019-3-##	10	32.5	27.8	22.5	55	02		
HNC1-2.5P-12DSL(##)	CL0218-0010-9-##	12	35.5	32.8	27.5	55	02	Fig.6	
HNC2-2.5P-15DSL(##)	CL0218-0047-9-##	15	45.0	40.4	35.0	55	01	Fig.5	

Note : The series name for the 12 position connector is HNC1 and varies slightly in design.

Socket Crimp Contact

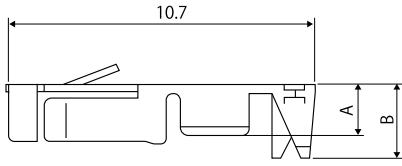

Unit : mm

Part No.	A	B
HNC-2.5S-C-A(15)	1.8	2.6
HNC-2.5S-C-A(02)		
HNC-2.5S-D-A(15)		
HNC-2.5S-D-A(02)		
HNC-2.5S-C-B(15)	1.5	1.7
HNC-2.5S-C-B(02)		
HNC-2.5S-D-B(15)		
HNC-2.5S-D-B(02)		

● Reel Contact (Applicable Tool : Applicator)

Part No.	HRS No.	Finish	Applicable Wire (Tin Plated Annealing Copper Wire) (Note 2)					Purchase Unit
			UL	AWG	Wire Construction	Sectional Area	Jacket Diameter	
HNC-2.5S-C-A(15) HNC-2.5S-C-A(02)	CL0218-0021-5-15 CL0218-0021-5-02	Tin Plated Gold Plated	1007	22	17/0.16mm	0.342mm ²	1.35 to 1.7mm	10,000pcs per reel
				24	11/0.16mm	0.221mm ²		
				26	7/0.16mm	0.141mm ²		
HNC-2.5S-C-B(15) HNC-2.5S-C-B(02)	CL0218-0020-2-15 CL0218-0020-2-02	Tin Plated Gold Plated	1061,1007	26	7/0.16mm	0.141mm ²	1.0 to 1.35mm	
				28	7/0.127mm	0.089mm ²		
				30	7/0.1mm	0.055mm ²		

● Loose Contact (Applicable Tool : Manual Crimping Tool)

Part No.	HRS No.	Finish	Applicable Wire (Tin Plated Annealing Copper Wire) (Note 2)					Purchase Unit
			UL	AWG	Wire Construction	Sectional Area	Jacket Diameter	
HNC-2.5S-D-A(15) HNC-2.5S-D-A(02)	CL0218-0037-5-15 CL0218-0037-5-02	Tin Plated Gold Plated	1007	22	17/0.16mm	0.342mm ²	1.6mm	100pcs per bag
				24	11/0.16mm	0.221mm ²	1.5mm	
				26	7/0.16mm	0.141mm ²	1.3mm	
HNC-2.5S-D-B(15) HNC-2.5S-D-B(02)	CL0218-0038-8-15 CL0218-0038-8-02	Tin Plated Gold Plated	1007	26	7/0.16mm	0.141mm ²	1.3mm	
				28	7/0.127mm	0.089mm ²	1.2mm	
				30	7/0.1mm	0.055mm ²	1.1mm	

Note : Please consult with a Hirose representative when using wires other than those specified.

Mated Diagram

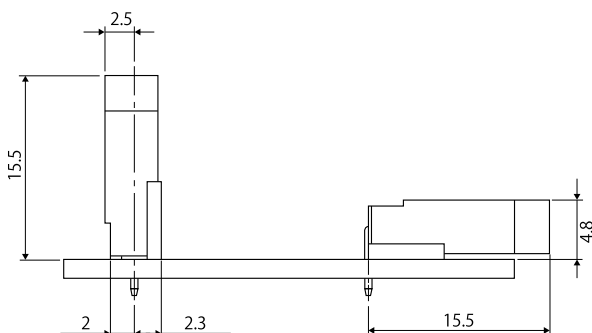

Applicable Crimping Tool

Type	Part No.	HRS No.	Applicable Contact
Applicator	AP105-HNC	CL0901-4502-0-00	HNC-2.5S-C-A(15)、HNC-2.5S-C-A(02) HNC-2.5S-C-B(15)、HNC-2.5S-C-B(02)
Press Main Unit	CM-105C	CL0901-0001-0-00	—
Manual Crimping Tool	TC-HNC-B	CL0250-0005-7-00	HNC-2.5S-D-B(15)、HNC-2.5S-D-B(02)
	TC-HNC-A	CL0250-0006-0-00	HNC-2.5S-D-A(15)、HNC-2.5S-D-A(02)
Extraction Tool	Flat-blade screwdriver (thickness < 0.75mm)		

Note 1 : Please conduct crimping work according to the "Crimping Quality Standard" (ETAD-H0980-00)" and "Crimping Condition Table".

Note 2 : Issues with non-Hirose specified tools are outside the scope of warranty.

Note 3 : When non-authorized tools are used, please consult with Hirose sales representative about provision of the drawing of the crimping tool.

Crimping

■ Items Required Prior to Starting

The work-related documents listed below are required before starting harness assembly.

The ● mark indicates a required document.

When the documents shown below are not available, ask a Hirose sales personnel to provide them.

Document Title	Description	Automatic Crimping Machine	Hand Crimping Tool	Remarks
1. Crimping Machine Main Unit Instruction Manual	Explanation of main press machine unit	●	-	Bundled with purchase of main press machine unit.
2. Applicator Instruction Manual	Crimp Method	●	-	Bundled with purchase of applicator.
3. Applicator Spare Parts List	Explanation for Applicator Installation	●	-	
4. Crimp Conditions	Standard crimp height and tensile strength values	●	-	
5. Crimp Quality Standards	Various standards for crimping conditions	●	-	
6. Operating Instructions for Hand Tool	Crimping method, standard crimp height and tensile strength values	-	●	Bundled with purchase of hand tool.
7. Cable Assembly Procedure	Cable Assembly Procedure	●	●	Ask a Hirose sales personnel to provide them.

■ Tools

The tools specified by Hirose should be used for crimping work.

Crimping work by tools other than those specified must not be done because it may result in contact failure, disconnection of cable, etc.

*The operating instructions manual is available for the crimping machine and the applicator.

Be sure to carefully read the operating instructions manual before implementing the work.

■ Applicable Electric Wires

Check that the electric wire to be used is within the applicable range.

If you intend to use an electric wire other than those recommended, ask a HRS sales personnel.

[Precautions]

- Electric wires that are suitable for crimping connectors are tin-plated stranded softcopper wire.
- Avoid crimping solid wires, wires with polyester threads or tin-coated wires.
- Avoid crimping two electric wires together.
- The crimp height setting value (Note) may vary between tin-plated and gold-plated contacts even if the same electric wires are used.
- The crimp height setting value (Note) may vary depending on the difference in the core wire configuration even if the computed cross-sectional area is the same.

Note : The crimp height is an important item that determines crimping quality. We execute crimping tests for each electric wire to ensure the optimal value for the crimp height with high precision, thereby ensuring optimal setup values.

Handling Precautions

1. Cleaning Conditions

Please refer to the "Wire-to-Board Connector Guide".

2. Handling Instructions

Please refer to the following documents.

- Crimp Quality Standard (ETAD-H0980-00)
- Wire-to-Board Connector Guide

While Taking into Consideration

Specifications mentioned in this catalog are reference values.

When considering to order or use this product, please confirm the Drawing and Product Specifications sheets.

Use an appropriate cable when using the connector in combination with cables.

If considering usage of a non-specified cable, please contact your sales representative.

If assembly process is done by jigs & tools which are not identified by Hirose, assurance will not be given.

If considering usage for below mentioned applications, please contact your sales representative.

In cases where the application will demand a high level of reliability, such as automotive, medical instruments, public infrastructure, aerospace/ defense etc. Hirose must review before assurance of reliability can be given.

