



POSITIVE VOLTAGE REGULATORS

- OUTPUT CURRENT TO 0.5A
- OUTPUT VOLTAGES OF 5; 6; 8; 9; 10; 12; 15; 18; 20; 24V
- THERMAL OVERLOAD PROTECTION
- SHORT CIRCUIT PROTECTION
- OUTPUT TRANSISTOR SOA PROTECTION

DESCRIPTION

The L78M00 series of three-terminal positive regulators is available in TO-220, ISOWATT220, SOT-82, SOT-194 and DPAK packages and with several fixed output voltages, making it useful in a wide range of applications. These regulators can provide local on-card regulation, eliminating the distribution problems associated with single point regulation. Each type employs internal current limiting, thermal shut-down and safe area protection, making it essentially indestructible. If adequate heat sinking is provided, they can deliver over 0.5A output current. Although designed primarily as fixed voltage regulators, these devices can be used with external components to obtain adjustable voltages and currents.

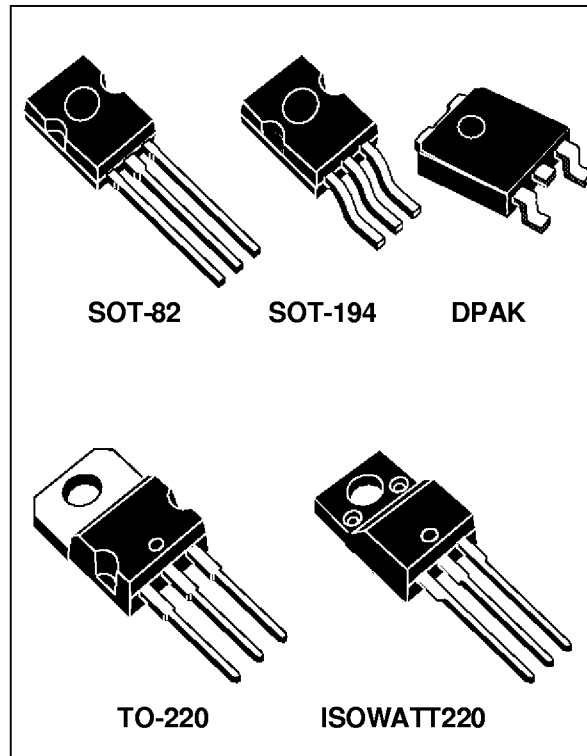

BLOCK DIAGRAM

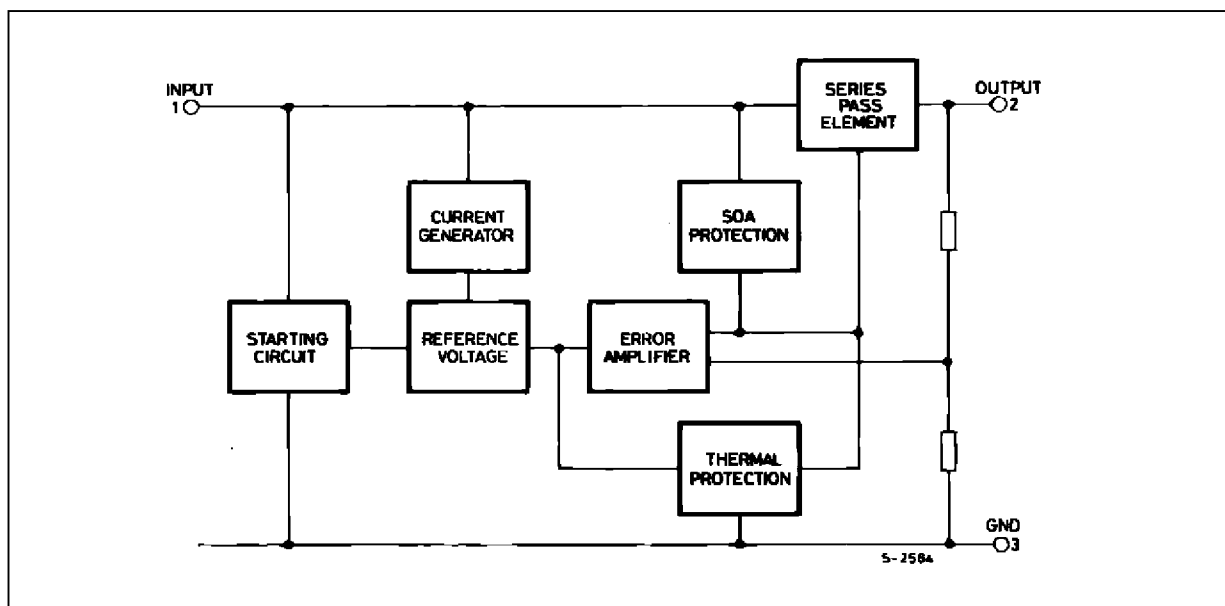

L78M00

ABSOLUTE MAXIMUM RATINGS

Symbol	Parameter	Value	Unit
V _i	DC Input Voltage (for V _O = 5 to 18V) (for V _O = 20, 24V)	35	V
		40	V
I _o	Output Current	Internally limited	
P _{tot}	Power Dissipation	Internally limited	
T _{op}	Operating Junction Temperature Range	0 to 150	°C
T _{stg}	Storage Temperature Range	- 65 to 150	°C

THERMAL DATA

Symbol	Parameter		SOT-82 SOT-194 DPAK	TO-220	ISOWATT220	Unit
R _{thj-case}	Thermal Resistance Junction-case	Max	8	3	4	°C/W
R _{thj-amb}	Thermal Resistance Junction-ambient	Max	100	50	60	°C/W

CONNECTION DIAGRAM AND ORDERING NUMBERS (top view)

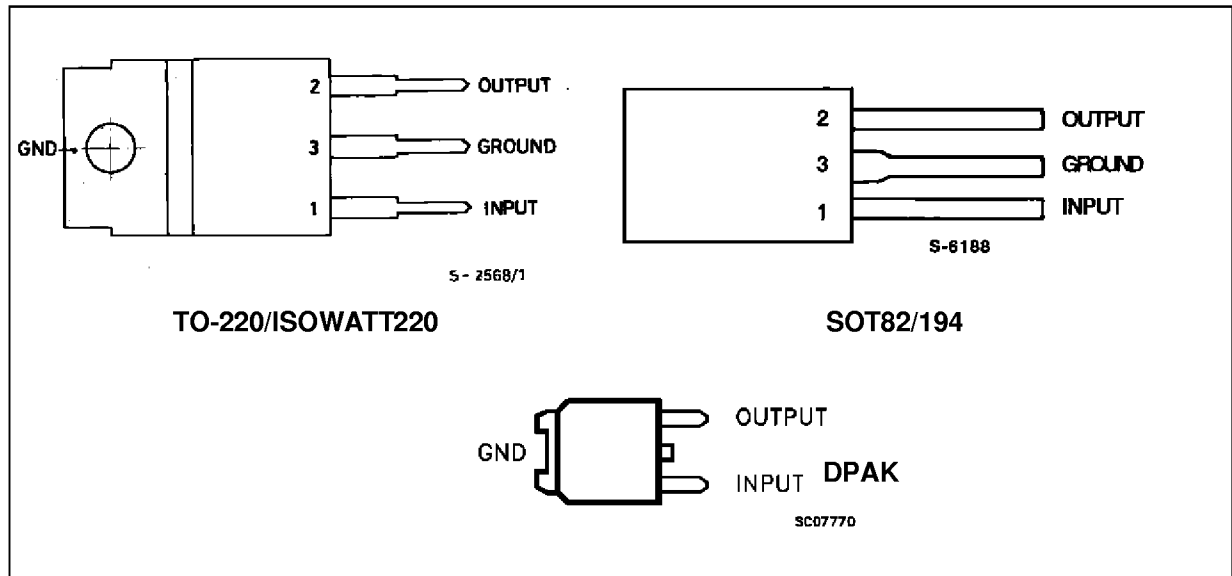

Order Code					Output Voltage
TO-220	ISOWATT220	SOT-82	SOT-194	DPAK	
L78M05CV	L78M05CP	L78M05CX	L78M05CS	L78M05CDT	5V
L78M06CV	L78M06CP	L78M06CX	L78M06CS	L78M06CDT	6V
L78M08CV	L78M08CP	L78M08CX	L78M08CS	L78M08CDT	8V
L78M09CV	L78M09CP	L78M09CX	L78M09CS	L78M09CDT	9V
L78M10CV	L78M10CP	L78M10CX	L78M10CS	L78M10CDT	10V
L78M12CV	L78M12CP	L78M12CX	L78M12CS	L78M12CDT	12V
L78M15CV	L78M15CP	L78M15CX	L78M15CS	L78M15CDT	15V
L78M18CV	L78M18CP	L78M18CX	L78M18CS	L78M18CDT	18V
L78M20CV	L78M20CP	L78M20CX	L78M20CS	L78M20CDT	20V
L78M24CV	L78M24CP	L78M24CX	L78M24CS	L78M24CDT	24V

APPLICATION CIRCUIT

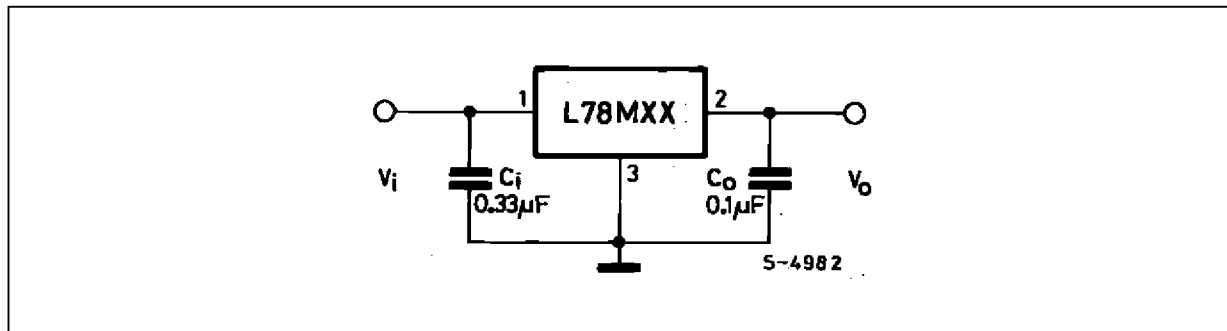

SCHEMATIC DIAGRAM

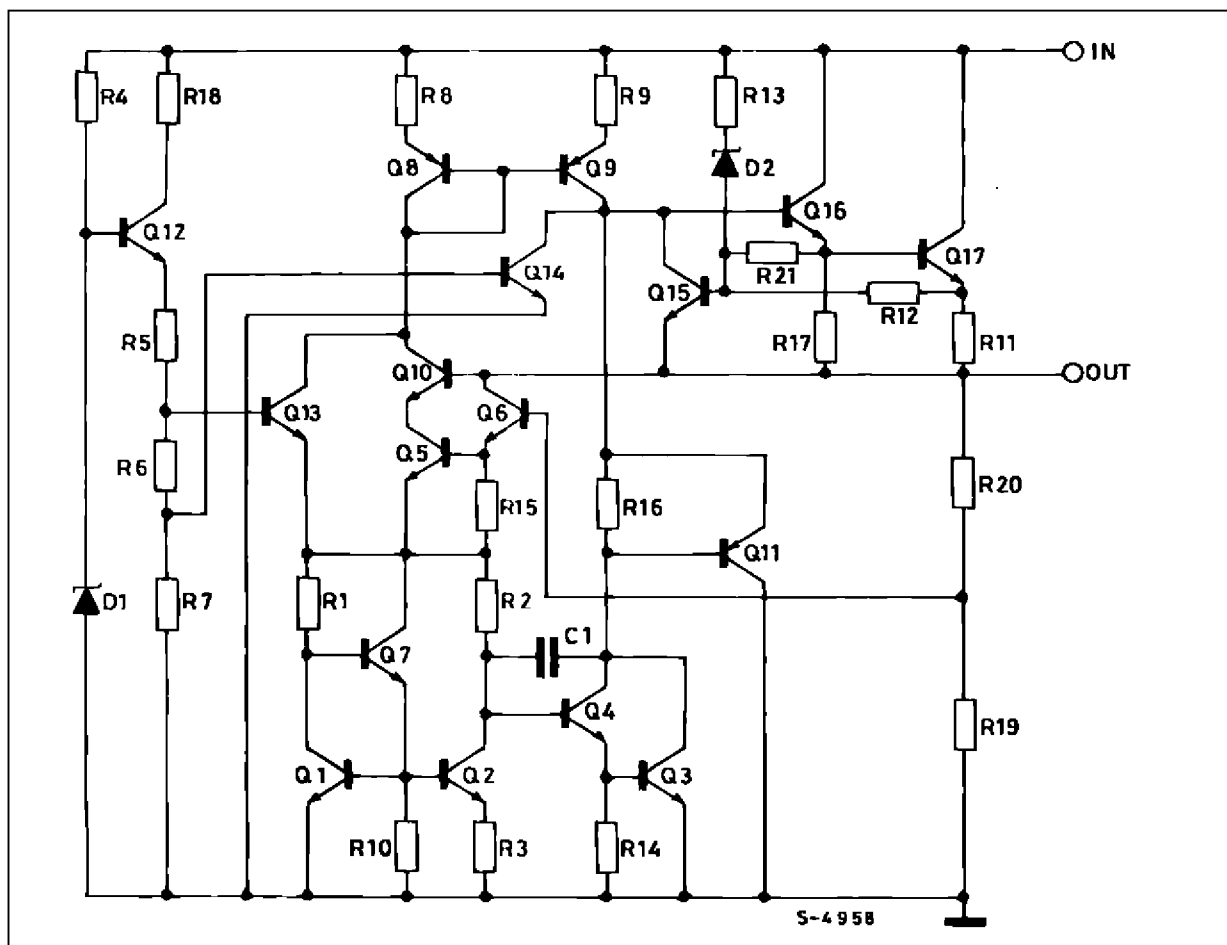

TEST CIRCUITS

Figure 1 : DC Parameters.

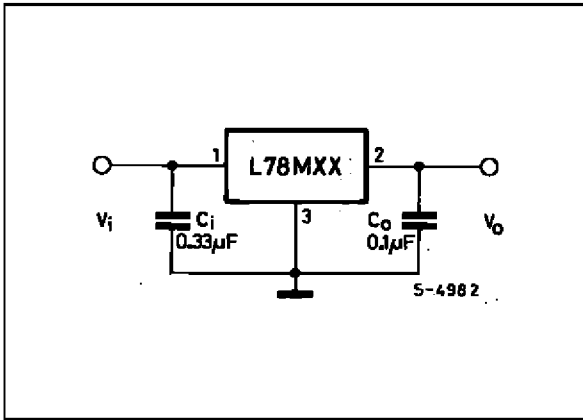

Figure 2 : Load Regulation.

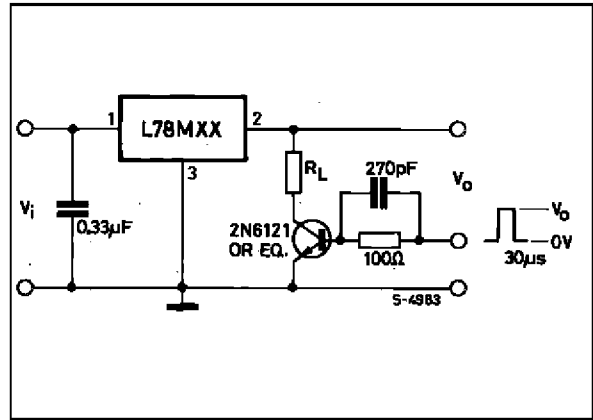
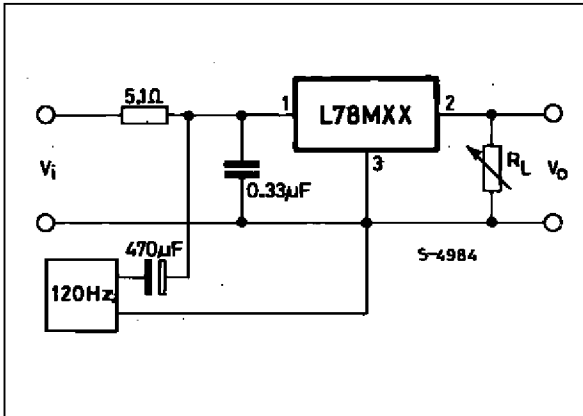

Figure 3 : Ripple Rejection.



ELECTRICAL CHARACTERISTICS FOR L78M05C (refer to the test circuits, $T_j = 25\text{ }^\circ\text{C}$,
 $V_i = 10\text{V}$, $I_o = 350\text{ mA}$, $C_i = 0.33\text{ }\mu\text{F}$, $C_o = 0.1\text{ }\mu\text{F}$ unless otherwise specified)

Symbol	Parameter	Test Conditions	Min.	Typ.	Max.	Unit
V_o	Output Voltage		4.8	5	5.2	V
V_o	Output Voltage	$I_o = 5\text{ mA to }350\text{ mA}$ $V_i = 7\text{ to }20\text{ V}$	4.75	5	5.25	V
ΔV_o	Line Regulation	$I_o = 200\text{ mA}$ $V_i = 7\text{ to }25\text{ V}$ $I_o = 200\text{ mA}$ $V_i = 8\text{ to }25\text{ V}$			100 50	mV mV
ΔV_o	Load Regulation	$I_o = 5\text{ to }500\text{ mA}$ $T_j = 25\text{ }^\circ\text{C}$ $I_o = 5\text{ to }200\text{ mA}$ $T_j = 25\text{ }^\circ\text{C}$			100 50	mV mV
I_d	Quiescent Current				6	mA
ΔI_d	Quiescent Current Change	$I_o = 5\text{ to }350\text{ mA}$			0.5	mA
ΔI_d	Quiescent Current Change	$I_o = 200\text{ mA}$ $V_i = 8\text{ to }25\text{ V}$			0.8	mA
$\frac{\Delta V_o}{\Delta T}$	Output Voltage Drift	$I_o = 5\text{ mA}$ $T_j = 0\text{ to }125\text{ }^\circ\text{C}$		-0.5		mV/ $^\circ\text{C}$
e_N	Output Noise Voltage	$B = 10\text{Hz to }100\text{KHz}$		40		μV
SVR	Supply Voltage Rejection	$I_o = 300\text{ mA}$ $f = 120\text{ Hz}$ $V_i = 8\text{ to }18\text{ V}$	62			dB
V_d	Dropout Voltage			2		V
I_{sc}	Short Circuit Current	$V_i = 35\text{ V}$		300		mA

ELECTRICAL CHARACTERISTICS FOR L78M06C (refer to the test circuits, $T_j = 25\text{ }^\circ\text{C}$,
 $V_i = 11\text{V}$, $I_o = 350\text{ mA}$, $C_i = 0.33\text{ }\mu\text{F}$, $C_o = 0.1\text{ }\mu\text{F}$ unless otherwise specified)

Symbol	Parameter	Test Conditions	Min.	Typ.	Max.	Unit
V_o	Output Voltage		5.75	6	6.25	V
V_o	Output Voltage	$I_o = 5\text{ mA to }350\text{ mA}$ $V_i = 8\text{ to }21\text{ V}$	5.7	6	6.3	V
ΔV_o	Line Regulation	$I_o = 200\text{ mA}$ $V_i = 8\text{ to }25\text{ V}$ $I_o = 200\text{ mA}$ $V_i = 9\text{ to }25\text{ V}$			100 50	mV mV
ΔV_o	Load Regulation	$I_o = 5\text{ to }500\text{ mA}$ $T_j = 25\text{ }^\circ\text{C}$ $I_o = 5\text{ to }200\text{ mA}$ $T_j = 25\text{ }^\circ\text{C}$			120 60	mV mV
I_d	Quiescent Current				6	mA
ΔI_d	Quiescent Current Change	$I_o = 5\text{ to }350\text{ mA}$			0.5	mA
ΔI_d	Quiescent Current Change	$I_o = 200\text{ mA}$ $V_i = 9\text{ to }25\text{ V}$			0.8	mA
$\frac{\Delta V_o}{\Delta T}$	Output Voltage Drift	$I_o = 5\text{ mA}$ $T_j = 0\text{ to }125\text{ }^\circ\text{C}$		-0.5		mV/ $^\circ\text{C}$
e_N	Output Noise Voltage	$B = 10\text{Hz to }100\text{KHz}$		45		μV
SVR	Supply Voltage Rejection	$I_o = 300\text{ mA}$ $f = 120\text{ Hz}$ $V_i = 9\text{ to }19\text{ V}$	59			dB
V_d	Dropout Voltage			2		V
I_{sc}	Short Circuit Current	$V_i = 35\text{ V}$		270		mA

L78M00

ELECTRICAL CHARACTERISTICS FOR L78M08C (refer to the test circuits, $T_j = 25\text{ }^\circ\text{C}$, $V_i = 14\text{V}$, $I_o = 350\text{ mA}$, $C_i = 0.33\text{ }\mu\text{F}$, $C_o = 0.1\text{ }\mu\text{F}$ unless otherwise specified)

Symbol	Parameter	Test Conditions	Min.	Typ.	Max.	Unit
V_o	Output Voltage		7.7	8	8.3	V
V_o	Output Voltage	$I_o = 5\text{ mA to }350\text{ mA}$ $V_i = 10.5\text{ to }23\text{ V}$	7.6	8	8.4	V
ΔV_o	Line Regulation	$I_o = 200\text{ mA}$ $V_i = 10.5\text{ to }25\text{ V}$ $I_o = 200\text{ mA}$ $V_i = 11\text{ to }25\text{ V}$			100 50	mV mV
ΔV_o	Load Regulation	$I_o = 5\text{ to }500\text{ mA}$ $T_j = 25\text{ }^\circ\text{C}$ $I_o = 5\text{ to }200\text{ mA}$ $T_j = 25\text{ }^\circ\text{C}$			160 80	mV mV
I_d	Quiescent Current				6	mA
ΔI_d	Quiescent Current Change	$I_o = 5\text{ to }350\text{ mA}$			0.5	mA
ΔI_d	Quiescent Current Change	$I_o = 200\text{ mA}$ $V_i = 10.5\text{ to }25\text{ V}$			0.8	mA
$\frac{\Delta V_o}{\Delta T}$	Output Voltage Drift	$I_o = 5\text{ mA}$ $T_j = 0\text{ to }125\text{ }^\circ\text{C}$		-0.5		mV/ $^\circ\text{C}$
e_N	Output Noise Voltage	$B = 10\text{Hz to }100\text{KHz}$		52		μV
SVR	Supply Voltage Rejection	$I_o = 300\text{ mA}$ $f = 120\text{ Hz}$ $V_i = 11.5\text{ to }21.5\text{ V}$	56			dB
V_d	Dropout Voltage			2		V
I_{sc}	Short Circuit Current	$V_i = 35\text{ V}$		250		mA

ELECTRICAL CHARACTERISTICS FOR L78M09C (refer to the test circuits, $T_j = 25\text{ }^\circ\text{C}$, $V_i = 15\text{V}$, $I_o = 350\text{ mA}$, $C_i = 0.33\text{ }\mu\text{F}$, $C_o = 0.1\text{ }\mu\text{F}$ unless otherwise specified)

Symbol	Parameter	Test Conditions	Min.	Typ.	Max.	Unit
V_o	Output Voltage		8.65	9	9.35	V
V_o	Output Voltage	$I_o = 5\text{ mA to }350\text{ mA}$ $V_i = 11.5\text{ to }24\text{ V}$	8.55	9	9.45	V
ΔV_o	Line Regulation	$I_o = 200\text{ mA}$ $V_i = 11.5\text{ to }25\text{ V}$ $I_o = 200\text{ mA}$ $V_i = 12\text{ to }25\text{ V}$			100 50	mV mV
ΔV_o	Load Regulation	$I_o = 5\text{ to }500\text{ mA}$ $T_j = 25\text{ }^\circ\text{C}$ $I_o = 5\text{ to }200\text{ mA}$ $T_j = 25\text{ }^\circ\text{C}$			180 90	mV mV
I_d	Quiescent Current				6	mA
ΔI_d	Quiescent Current Change	$I_o = 5\text{ to }350\text{ mA}$			0.5	mA
ΔI_d	Quiescent Current Change	$I_o = 200\text{ mA}$ $V_i = 11.5\text{ to }25\text{ V}$			0.8	mA
$\frac{\Delta V_o}{\Delta T}$	Output Voltage Drift	$I_o = 5\text{ mA}$ $T_j = 0\text{ to }125\text{ }^\circ\text{C}$		-0.5		mV/ $^\circ\text{C}$
e_N	Output Noise Voltage	$B = 10\text{Hz to }100\text{KHz}$		58		μV
SVR	Supply Voltage Rejection	$I_o = 300\text{ mA}$ $f = 120\text{ Hz}$ $V_i = 12.5\text{ to }23\text{ V}$	56			dB
V_d	Dropout Voltage			2		V
I_{sc}	Short Circuit Current	$V_i = 35\text{ V}$		250		mA

ELECTRICAL CHARACTERISTICS FOR L78M10C (refer to the test circuits, $T_j = 25\text{ }^\circ\text{C}$,
 $V_i = 16\text{V}$, $I_o = 350\text{ mA}$, $C_i = 0.33\text{ }\mu\text{F}$, $C_o = 0.1\text{ }\mu\text{F}$ unless otherwise specified)

Symbol	Parameter	Test Conditions	Min.	Typ.	Max.	Unit
V_o	Output Voltage		9.6	10	10.4	V
V_o	Output Voltage	$I_o = 5\text{ mA to }350\text{ mA}$ $V_i = 12.5\text{ to }25\text{ V}$	9.5	10	10.5	V
ΔV_o	Line Regulation	$I_o = 200\text{ mA}$ $V_i = 12.5\text{ to }30\text{ V}$ $I_o = 200\text{ mA}$ $V_i = 13\text{ to }30\text{ V}$			100 50	mV mV
ΔV_o	Load Regulation	$I_o = 5\text{ to }500\text{ mA}$ $T_j = 25\text{ }^\circ\text{C}$ $I_o = 5\text{ to }200\text{ mA}$ $T_j = 25\text{ }^\circ\text{C}$			200 100	mV mV
I_d	Quiescent Current				6	mA
ΔI_d	Quiescent Current Change	$I_o = 5\text{ to }350\text{ mA}$			0.5	mA
ΔI_d	Quiescent Current Change	$I_o = 200\text{ mA}$ $V_i = 12.5\text{ to }30\text{ V}$			0.8	mA
$\frac{\Delta V_o}{\Delta T}$	Output Voltage Drift	$I_o = 5\text{ mA}$ $T_j = 0\text{ to }125\text{ }^\circ\text{C}$		-0.5		mV/ $^\circ\text{C}$
e_N	Output Noise Voltage	$B = 10\text{Hz to }100\text{KHz}$		64		μV
SVR	Supply Voltage Rejection	$I_o = 300\text{ mA}$ $f = 120\text{ Hz}$ $V_i = 13.5\text{ to }24\text{ V}$	56			dB
V_d	Dropout Voltage			2		V
I_{sc}	Short Circuit Current	$V_i = 35\text{ V}$		245		mA

ELECTRICAL CHARACTERISTICS FOR L78M12C (refer to the test circuits, $T_j = 25\text{ }^\circ\text{C}$,
 $V_i = 19\text{V}$, $I_o = 350\text{ mA}$, $C_i = 0.33\text{ }\mu\text{F}$, $C_o = 0.1\text{ }\mu\text{F}$ unless otherwise specified)

Symbol	Parameter	Test Conditions	Min.	Typ.	Max.	Unit
V_o	Output Voltage		11.5	12	12.5	V
V_o	Output Voltage	$I_o = 5\text{ mA to }350\text{ mA}$ $V_i = 14.5\text{ to }27\text{ V}$	11.4	12	12.6	V
ΔV_o	Line Regulation	$I_o = 200\text{ mA}$ $V_i = 14.5\text{ to }30\text{ V}$ $I_o = 200\text{ mA}$ $V_i = 16\text{ to }30\text{ V}$			100 50	mV mV
ΔV_o	Load Regulation	$I_o = 5\text{ to }500\text{ mA}$ $T_j = 25\text{ }^\circ\text{C}$ $I_o = 5\text{ to }200\text{ mA}$ $T_j = 25\text{ }^\circ\text{C}$			240 120	mV mV
I_d	Quiescent Current				6	mA
ΔI_d	Quiescent Current Change	$I_o = 5\text{ to }350\text{ mA}$			0.5	mA
ΔI_d	Quiescent Current Change	$I_o = 200\text{ mA}$ $V_i = 14.5\text{ to }30\text{ V}$			0.8	mA
$\frac{\Delta V_o}{\Delta T}$	Output Voltage Drift	$I_o = 5\text{ mA}$ $T_j = 0\text{ to }125\text{ }^\circ\text{C}$		-1		mV/ $^\circ\text{C}$
e_N	Output Noise Voltage	$B = 10\text{Hz to }100\text{KHz}$		75		μV
SVR	Supply Voltage Rejection	$I_o = 300\text{ mA}$ $f = 120\text{ Hz}$ $V_i = 15\text{ to }25\text{ V}$	55			dB
V_d	Dropout Voltage			2		V
I_{sc}	Short Circuit Current	$V_i = 35\text{ V}$		240		mA

L78M00

ELECTRICAL CHARACTERISTICS FOR L78M15C (refer to the test circuits, $T_j = 25\text{ }^\circ\text{C}$, $V_i = 23\text{V}$, $I_o = 350\text{ mA}$, $C_i = 0.33\text{ }\mu\text{F}$, $C_o = 0.1\text{ }\mu\text{F}$ unless otherwise specified)

Symbol	Parameter	Test Conditions	Min.	Typ.	Max.	Unit
V_o	Output Voltage		14.4	15	15.6	V
V_o	Output Voltage	$I_o = 5\text{ mA to }350\text{ mA}$ $V_i = 17.5\text{ to }30\text{ V}$	14.25	15	15.75	V
ΔV_o	Line Regulation	$I_o = 200\text{ mA}$ $V_i = 17.5\text{ to }30\text{ V}$ $I_o = 200\text{ mA}$ $V_i = 20\text{ to }30\text{ V}$			100 50	mV mV
ΔV_o	Load Regulation	$I_o = 5\text{ to }500\text{ mA}$ $T_j = 25\text{ }^\circ\text{C}$ $I_o = 5\text{ to }200\text{ mA}$ $T_j = 25\text{ }^\circ\text{C}$			300 150	mV mV
I_d	Quiescent Current				6	mA
ΔI_d	Quiescent Current Change	$I_o = 5\text{ to }350\text{ mA}$			0.5	mA
ΔI_d	Quiescent Current Change	$I_o = 200\text{ mA}$ $V_i = 17.5\text{ to }30\text{ V}$			0.8	mA
$\frac{\Delta V_o}{\Delta T}$	Output Voltage Drift	$I_o = 5\text{ mA}$ $T_j = 0\text{ to }125\text{ }^\circ\text{C}$		-1		mV/ $^\circ\text{C}$
e_N	Output Noise Voltage	$B = 10\text{Hz to }100\text{KHz}$		90		μV
SVR	Supply Voltage Rejection	$I_o = 300\text{ mA}$ $f = 120\text{ Hz}$ $V_i = 18.5\text{ to }28.5\text{ V}$	54			dB
V_d	Dropout Voltage			2		V
I_{sc}	Short Circuit Current	$V_i = 35\text{ V}$		240		mA

ELECTRICAL CHARACTERISTICS FOR L78M18C (refer to the test circuits, $T_j = 25\text{ }^\circ\text{C}$, $V_i = 26\text{V}$, $I_o = 350\text{ mA}$, $C_i = 0.33\text{ }\mu\text{F}$, $C_o = 0.1\text{ }\mu\text{F}$ unless otherwise specified)

Symbol	Parameter	Test Conditions	Min.	Typ.	Max.	Unit
V_o	Output Voltage		17.3	18	18.7	V
V_o	Output Voltage	$I_o = 5\text{ mA to }350\text{ mA}$ $V_i = 20.5\text{ to }33\text{ V}$	17.1	18	18.9	V
ΔV_o	Line Regulation	$I_o = 200\text{ mA}$ $V_i = 21\text{ to }33\text{ V}$ $I_o = 200\text{ mA}$ $V_i = 24\text{ to }33\text{ V}$			100 50	mV mV
ΔV_o	Load Regulation	$I_o = 5\text{ to }500\text{ mA}$ $T_j = 25\text{ }^\circ\text{C}$ $I_o = 5\text{ to }200\text{ mA}$ $T_j = 25\text{ }^\circ\text{C}$			360 180	mV mV
I_d	Quiescent Current				6	mA
ΔI_d	Quiescent Current Change	$I_o = 5\text{ to }350\text{ mA}$			0.5	mA
ΔI_d	Quiescent Current Change	$I_o = 200\text{ mA}$ $V_i = 21\text{ to }33\text{ V}$			0.8	mA
$\frac{\Delta V_o}{\Delta T}$	Output Voltage Drift	$I_o = 5\text{ mA}$ $T_j = 0\text{ to }125\text{ }^\circ\text{C}$		-1.1		mV/ $^\circ\text{C}$
e_N	Output Noise Voltage	$B = 10\text{Hz to }100\text{KHz}$		100		μV
SVR	Supply Voltage Rejection	$I_o = 300\text{ mA}$ $f = 120\text{ Hz}$ $V_i = 22\text{ to }32\text{ V}$	53			dB
V_d	Dropout Voltage			2		V
I_{sc}	Short Circuit Current	$V_i = 35\text{ V}$		240		mA

ELECTRICAL CHARACTERISTICS FOR L78M20C (refer to the test circuits, $T_j = 25\text{ }^\circ\text{C}$,
 $V_i = 29\text{V}$, $I_o = 350\text{ mA}$, $C_i = 0.33\text{ }\mu\text{F}$, $C_o = 0.1\text{ }\mu\text{F}$ unless otherwise specified)

Symbol	Parameter	Test Conditions	Min.	Typ.	Max.	Unit
V_o	Output Voltage		19.2	20	20.8	V
V_o	Output Voltage	$I_o = 5\text{ mA to }350\text{ mA}$ $V_i = 23\text{ to }35\text{ V}$	19	20	21	V
ΔV_o	Line Regulation	$I_o = 200\text{ mA}$ $V_i = 23\text{ to }35\text{ V}$ $I_o = 200\text{ mA}$ $V_i = 24\text{ to }35\text{ V}$			100 50	mV mV
ΔV_o	Load Regulation	$I_o = 5\text{ to }500\text{ mA}$ $T_j = 25\text{ }^\circ\text{C}$ $I_o = 5\text{ to }200\text{ mA}$ $T_j = 25\text{ }^\circ\text{C}$			400 200	mV mV
I_d	Quiescent Current				6	mA
ΔI_d	Quiescent Current Change	$I_o = 5\text{ to }350\text{ mA}$			0.5	mA
ΔI_d	Quiescent Current Change	$I_o = 200\text{ mA}$ $V_i = 23\text{ to }35\text{ V}$			0.8	mA
$\frac{\Delta V_o}{\Delta T}$	Output Voltage Drift	$I_o = 5\text{ mA}$ $T_j = 0\text{ to }125\text{ }^\circ\text{C}$		-1.1		mV/ $^\circ\text{C}$
e_N	Output Noise Voltage	$B = 10\text{Hz to }100\text{KHz}$		110		μV
SVR	Supply Voltage Rejection	$I_o = 300\text{ mA}$ $f = 120\text{ Hz}$ $V_i = 24\text{ to }34\text{ V}$	53			dB
V_d	Dropout Voltage			2		V
I_{sc}	Short Circuit Current	$V_i = 35\text{ V}$		240		mA

ELECTRICAL CHARACTERISTICS FOR L78M24C (refer to the test circuits, $T_j = 25\text{ }^\circ\text{C}$,
 $V_i = 33\text{V}$, $I_o = 350\text{ mA}$, $C_i = 0.33\text{ }\mu\text{F}$, $C_o = 0.1\text{ }\mu\text{F}$ unless otherwise specified)

Symbol	Parameter	Test Conditions	Min.	Typ.	Max.	Unit
V_o	Output Voltage		23	24	25	V
V_o	Output Voltage	$I_o = 5\text{ mA to }350\text{ mA}$ $V_i = 27\text{ to }38\text{ V}$	22.8	24	25.2	V
ΔV_o	Line Regulation	$I_o = 200\text{ mA}$ $V_i = 27\text{ to }38\text{ V}$ $I_o = 200\text{ mA}$ $V_i = 28\text{ to }38\text{ V}$			100 50	mV mV
ΔV_o	Load Regulation	$I_o = 5\text{ to }500\text{ mA}$ $T_j = 25\text{ }^\circ\text{C}$ $I_o = 5\text{ to }200\text{ mA}$ $T_j = 25\text{ }^\circ\text{C}$			480 240	mV mV
I_d	Quiescent Current				6	mA
ΔI_d	Quiescent Current Change	$I_o = 5\text{ to }350\text{ mA}$			0.5	mA
ΔI_d	Quiescent Current Change	$I_o = 200\text{ mA}$ $V_i = 27\text{ to }38\text{ V}$			0.8	mA
$\frac{\Delta V_o}{\Delta T}$	Output Voltage Drift	$I_o = 5\text{ mA}$ $T_j = 0\text{ to }125\text{ }^\circ\text{C}$		-1.2		mV/ $^\circ\text{C}$
e_N	Output Noise Voltage	$B = 10\text{Hz to }100\text{KHz}$		170		μV
SVR	Supply Voltage Rejection	$I_o = 300\text{ mA}$ $f = 120\text{ Hz}$ $V_i = 28\text{ to }38\text{ V}$	50			dB
V_d	Dropout Voltage			2		V
I_{sc}	Short Circuit Current	$V_i = 35\text{ V}$		240		mA

Figure 4 : Dropout Voltage vs. Junction Temperature.

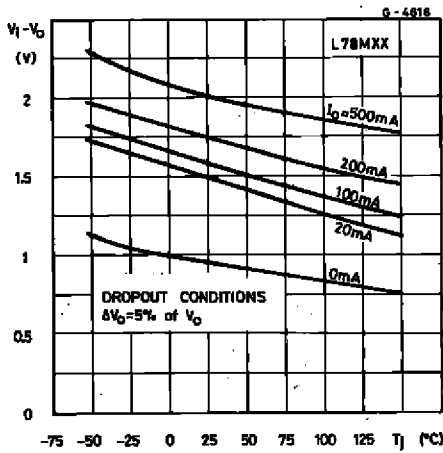

Figure 5 : Dropout Characteristics.

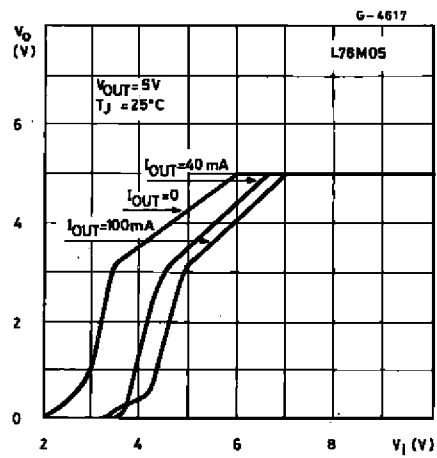

Figure 6 : Peak Output Current vs. Input-Output Differential Voltage.

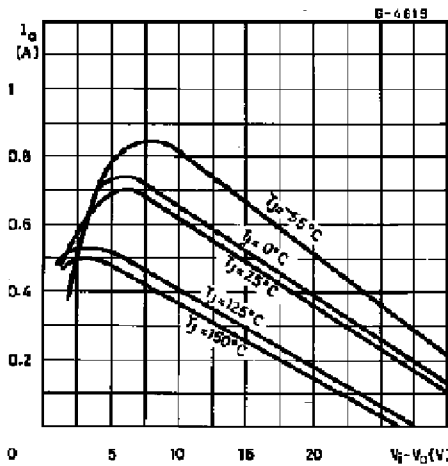

Figure 7 : Output Voltage vs. Junction Temperature.

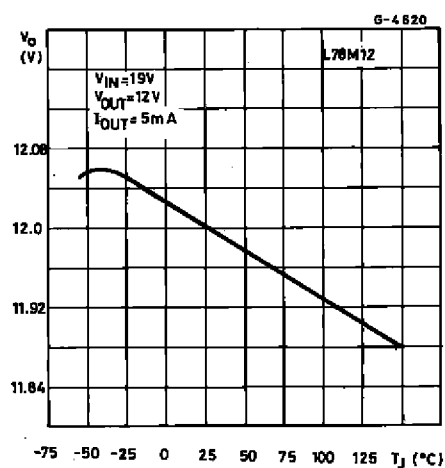

Figure 8 : Supply Voltage Rejection vs. Frequency.

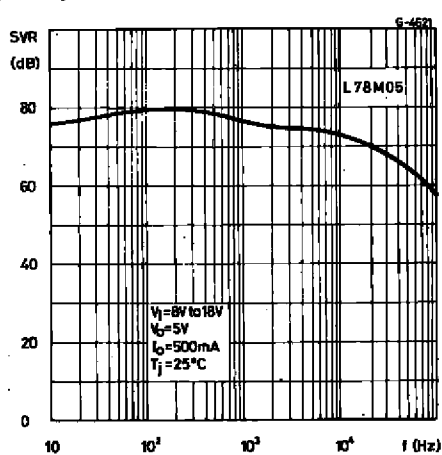

Figure 9 : Quiescent Current vs. Junction Temperature.

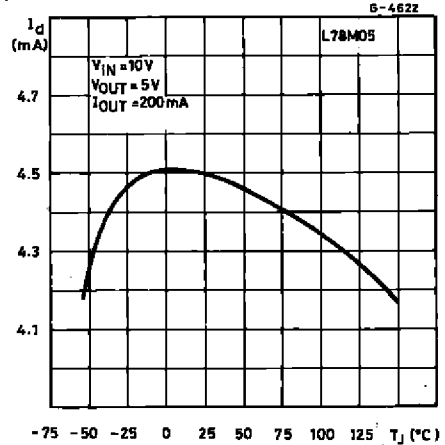

Figure 10 : Load Transient Response.

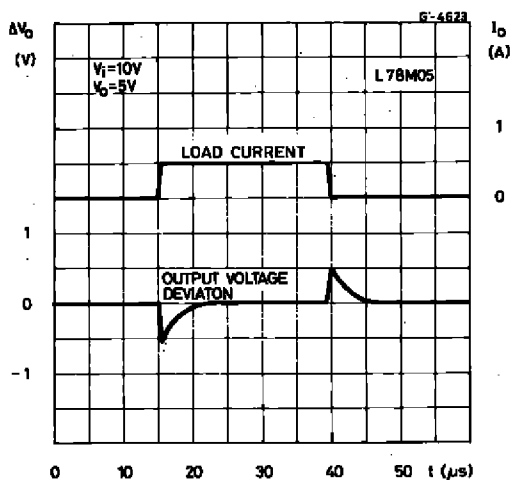

Figure 12 : Quiescent Current vs. Input Voltage.

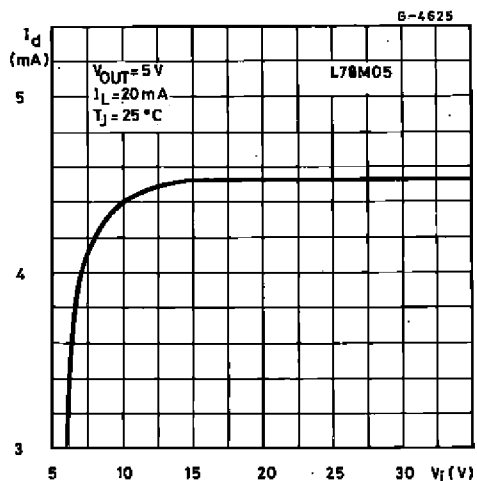

Figure 11 : Line Transient Response.

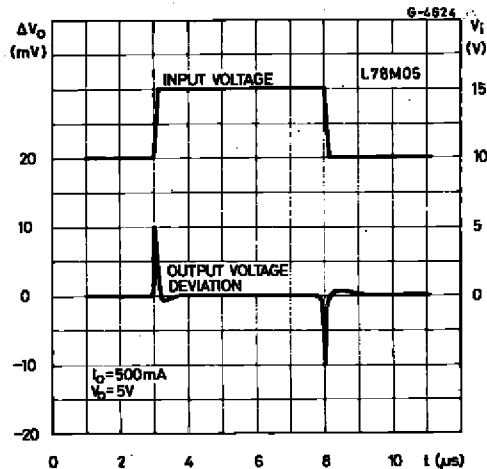
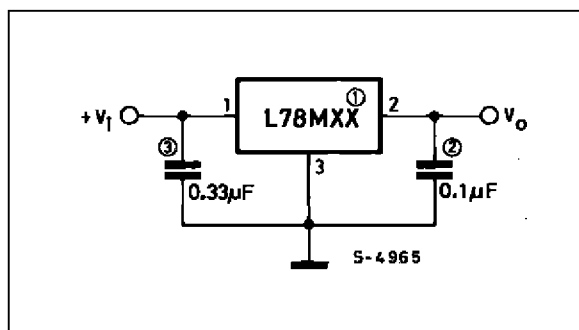
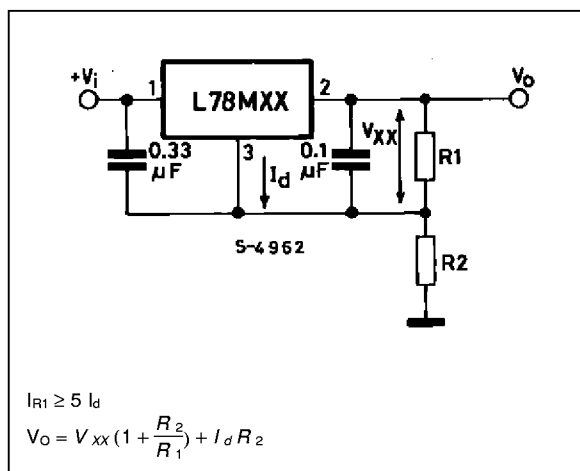
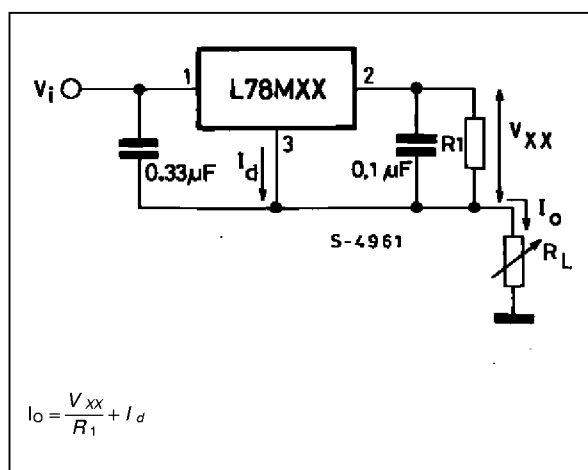

Figure 13 : Fixed Output Regulator.



NOTE:

1. To specify an output voltage, substitute voltage value for "XX".
2. Although no output capacitor is need for stability, it does improve transient response.
3. Required if regulator is locate an appreciable distance from power supply filter.



L78M00

Figure 16 : Adjustable Output Regulator (7 to 30V).

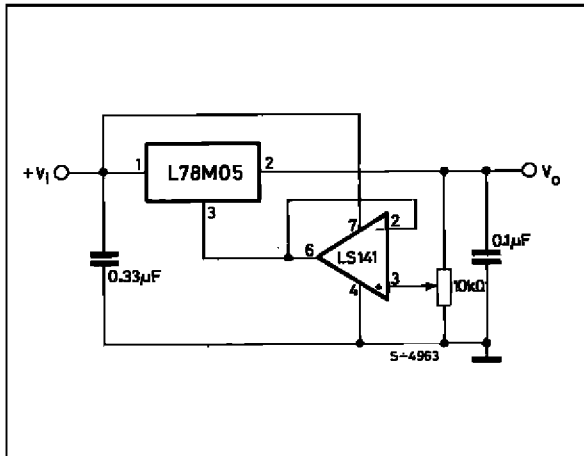

Figure 17 : 0.5 to 10V Regulator.

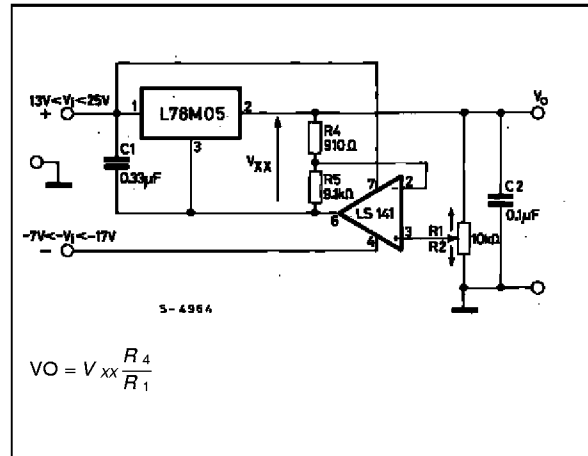

Figure 18 : High Current Voltage Regulator.

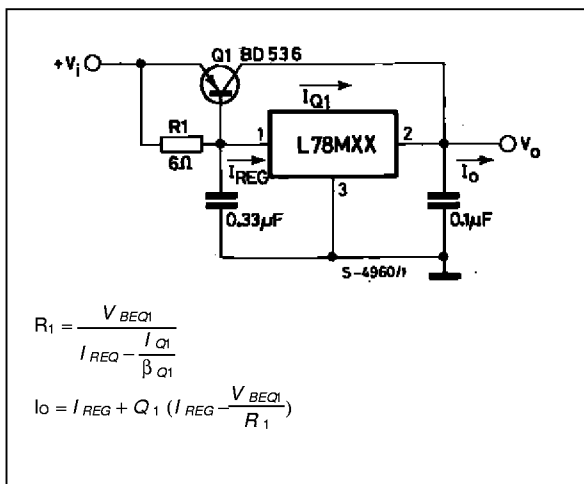

Figure 19 : High Output Current with Short Circuit

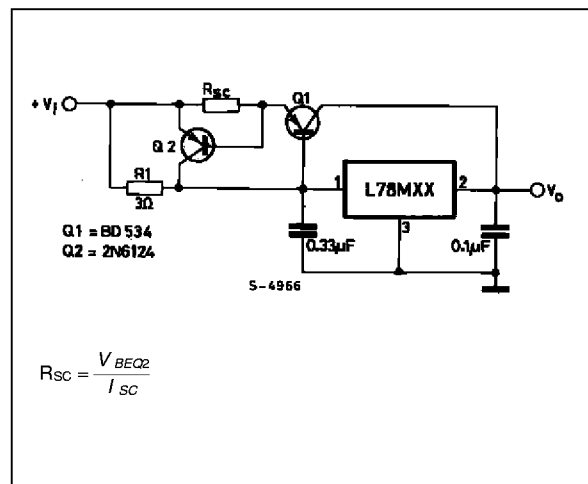

Figure 20 : Tracking Voltage Regulator.

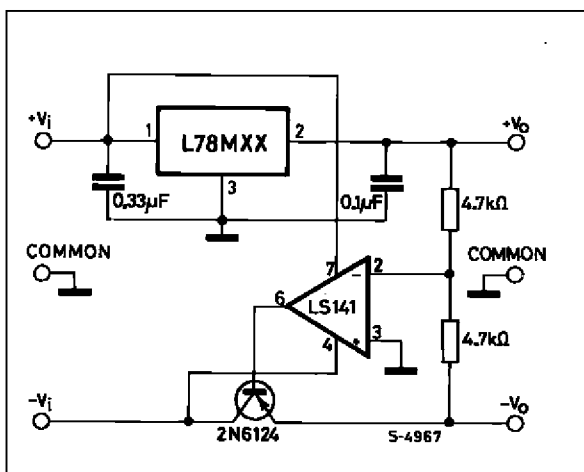

Figure 21 : High Input Voltage Circuit.

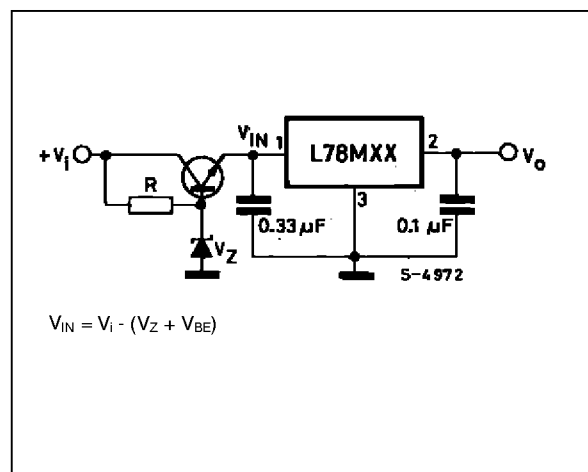

Figure 22 : Reducing Power Dissipation with Dropping Resistor.

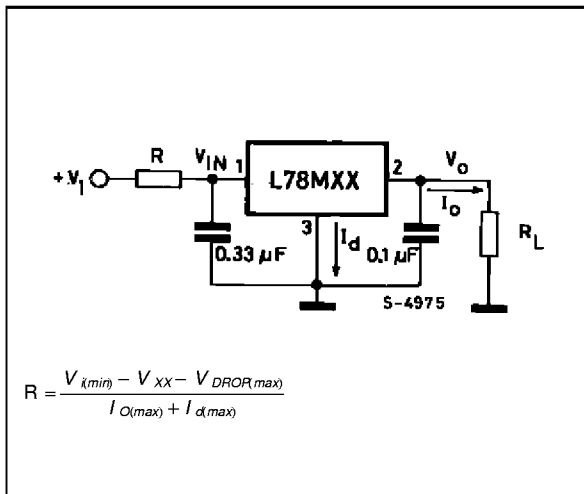
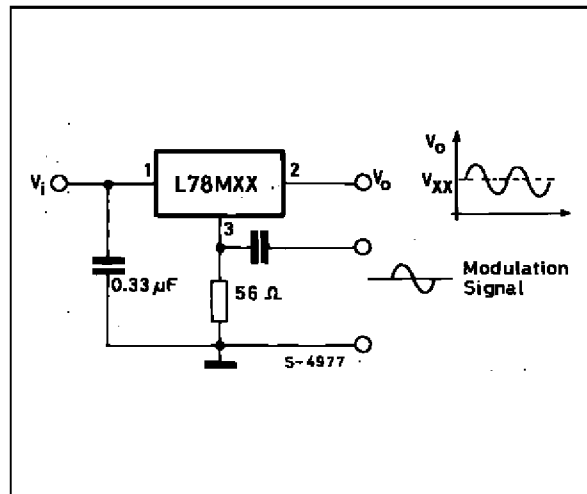
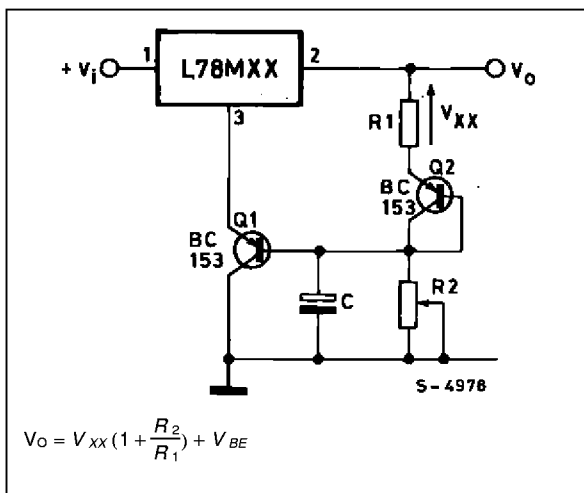

Figure 23 : Power AM Modulator (unity voltage gain, $I_o \leq 0.5$).



NOTE: The circuit performs well up to 100KHz

Figure 24 : Adjustable Output Voltage with Temperature Compensation.



NOTE: Q₂ is connected as a diode in order to compensate the variation of the Q₁ V_{BE} with the temperature. C allows a slow rise-time of the V_o

SOT-82 MECHANICAL DATA

DIM.	mm			inch		
	MIN.	TYP.	MAX.	MIN.	TYP.	MAX.
A	7.4		7.8	0.291		0.307
B	10.5		11.3	0.413		0.445
b	0.7		0.9	0.028		0.035
b1	0.49		0.75	0.019		0.030
C	2.4		2.7	0.04		0.106
c1		1.2			0.047	
D		15.7			0.618	
e		2.2			0.087	
e3		4.4			0.173	
F		3.8			0.150	
H			2.54		0.100	

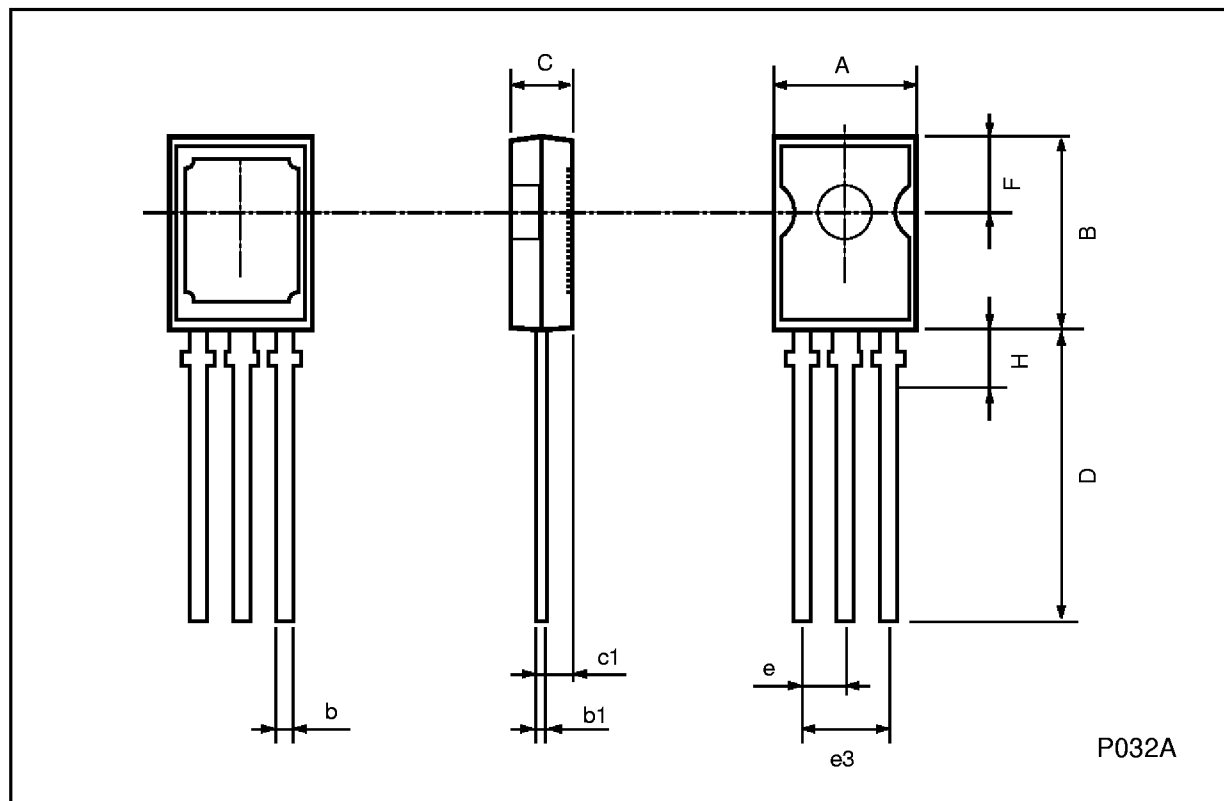

SOT-194 MECHANICAL DATA

DIM.	mm			inch		
	MIN.	TYP.	MAX.	MIN.	TYP.	MAX.
A	7.4		7.8	0.291		0.307
B	10.5		11.3	0.413		0.445
b	0.7		0.9	0.028		0.035
b1	0.49		0.75	0.019		0.030
C	2.4		2.7	0.094		0.106
c1		1.2			0.047	
c2		1.3			0.051	
D		6			0.236	
e		2.2			0.087	
e3		4.4			0.173	
F		3.8			0.150	
H			2.54			0.100
P	45 (typ.)					
S		4			0.157	
S1		2			0.079	
T		0.1			0.004	

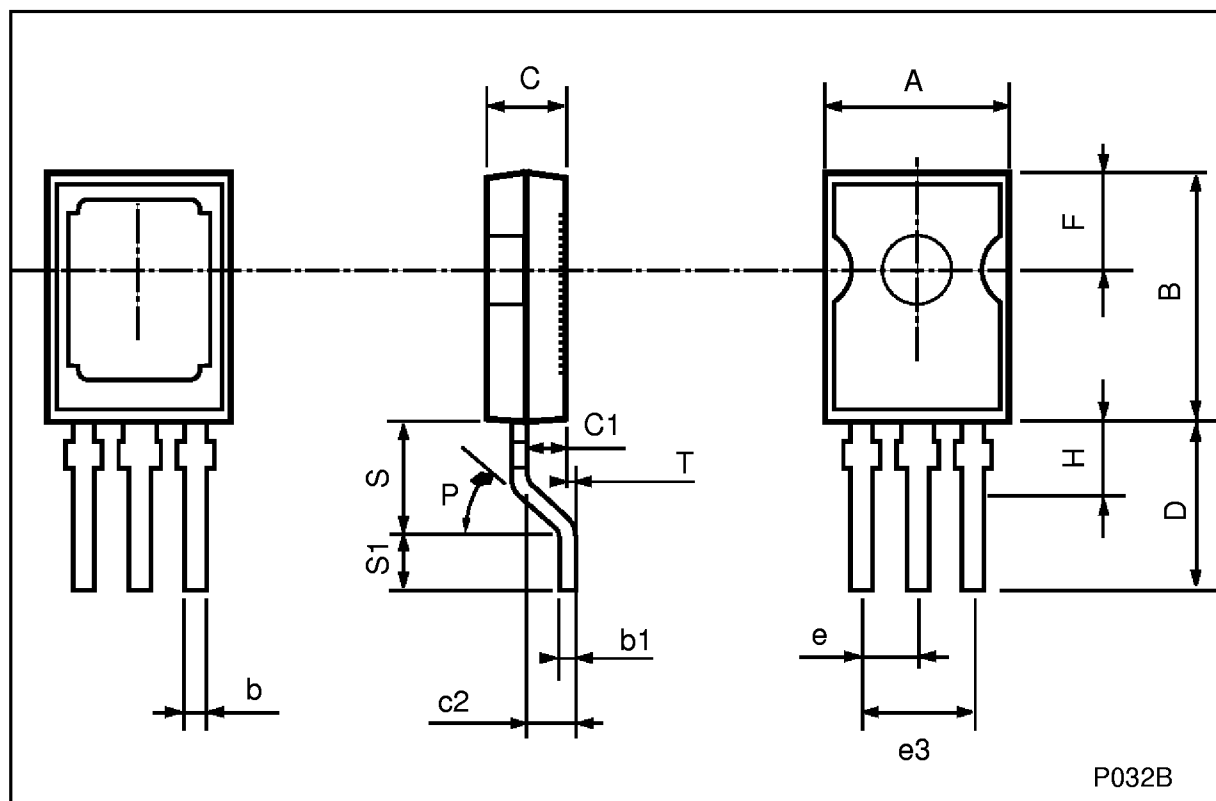

TO-252 (DPAK) MECHANICAL DATA

DIM.	mm			inch		
	MIN.	TYP.	MAX.	MIN.	TYP.	MAX.
A	2.2		2.4	0.086		0.094
A1	0.9		1.1	0.035		0.043
A2	0.03		0.23	0.001		0.009
B	0.64		0.9	0.025		0.035
B2	5.2		5.4	0.204		0.212
C	0.45		0.6	0.017		0.023
C2	0.48		0.6	0.019		0.023
D	6		6.2	0.236		0.244
E	6.4		6.6	0.252		0.260
G	4.4		4.6	0.173		0.181
H	9.35		10.1	0.368		0.397
L2		0.8			0.031	
L4	0.6		1	0.023		0.039

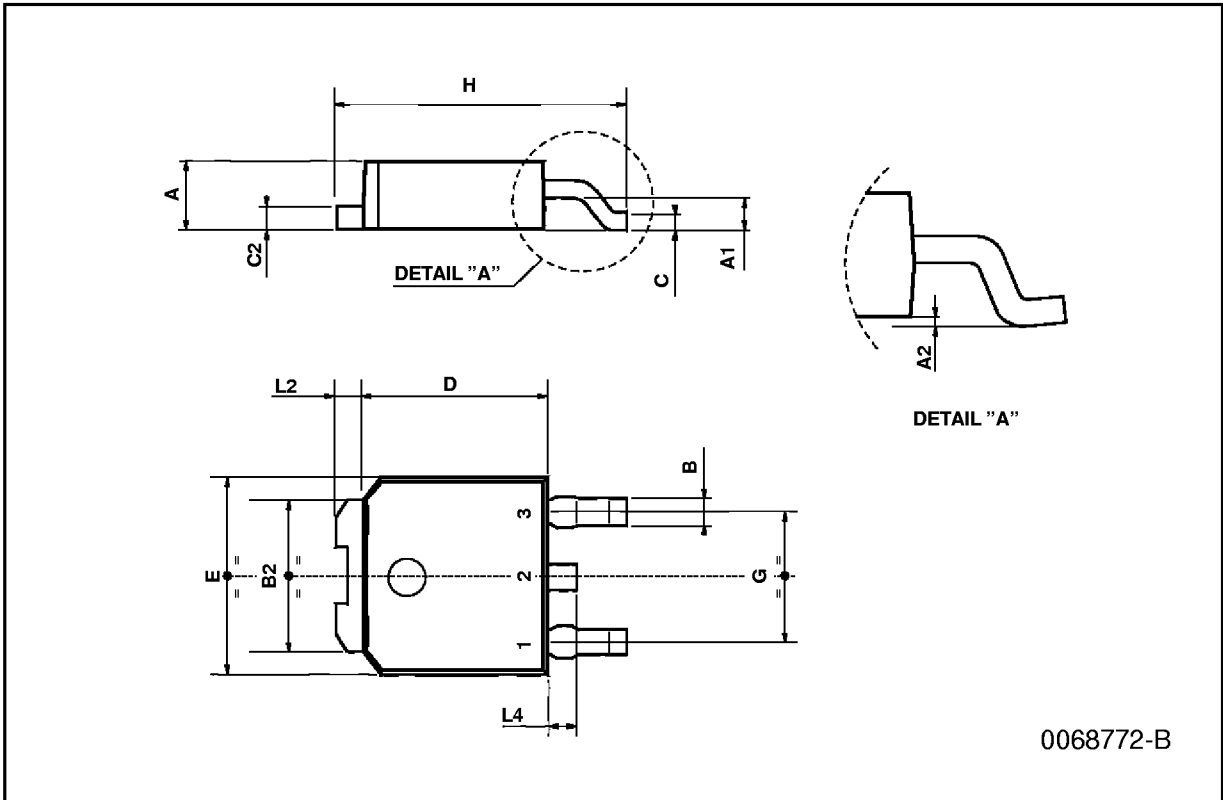

TO-220 MECHANICAL DATA

DIM.	mm			inch		
	MIN.	TYP.	MAX.	MIN.	TYP.	MAX.
A	4.40		4.60	0.173		0.181
C	1.23		1.32	0.048		0.051
D	2.40		2.72	0.094		0.107
D1		1.27			0.050	
E	0.49		0.70	0.019		0.027
F	0.61		0.88	0.024		0.034
F1	1.14		1.70	0.044		0.067
F2	1.14		1.70	0.044		0.067
G	4.95		5.15	0.194		0.203
G1	2.4		2.7	0.094		0.106
H2	10.0		10.40	0.393		0.409
L2		16.4			0.645	
L4	13.0		14.0	0.511		0.551
L5	2.65		2.95	0.104		0.116
L6	15.25		15.75	0.600		0.620
L7	6.2		6.6	0.244		0.260
L9	3.5		3.93	0.137		0.154
DIA.	3.75		3.85	0.147		0.151

