

T-43-21

8



# 54AC/74AC00 • 54ACT/74ACT00

## Quad 2-Input NAND Gate

### General Description

The 'AC/'ACT00 contains four 2-input NAND gates.

### Features

- $I_{CC}$  reduced by 50%
- Outputs source/sink 24 mA
- 'ACT00 has TTL-compatible inputs
- Standard Military Drawing (SMD)
  - 'AC00: 5962-87549
  - 'ACT00: 5962-87699

**Ordering Code:** See Section 8

### Logic Symbol

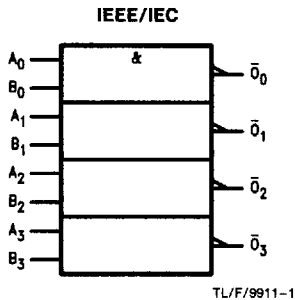

### Connection Diagrams

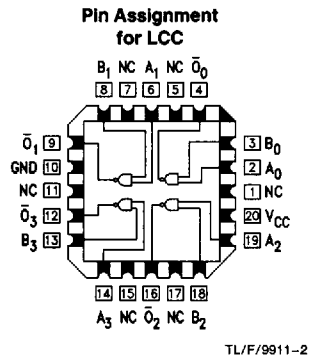
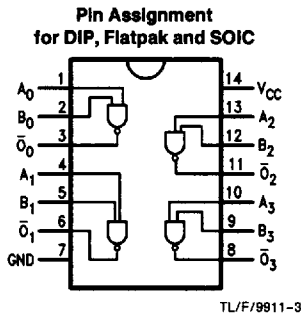

Pin Names	Description
$A_n, B_n$	Inputs
$\bar{O}_n$	Outputs

4

00

### Absolute Maximum Ratings (Note 1)

If Military/Aerospace specified devices are required, please contact the National Semiconductor Sales Office/Distributors for availability and specifications.

Supply Voltage ( $V_{CC}$ )	-0.5V to +7.0V
DC Input Diode Current ( $I_{IK}$ )	
$V_I = -0.5V$	-20 mA
$V_I = V_{CC} + 0.5V$	+20 mA
DC Input Voltage ( $V_I$ )	-0.5V to $V_{CC} + 0.5V$
DC Output Diode Current ( $I_{OK}$ )	
$V_O = -0.5V$	-20 mA
$V_O = V_{CC} + 0.5V$	+20 mA
DC Output Voltage ( $V_O$ )	-0.5V to $V_{CC} + 0.5V$
DC Output Source or Sink Current ( $I_O$ )	±50 mA
DC $V_{CC}$ or Ground Current per Output Pin ( $I_{CC}$ or $I_{GND}$ )	±50 mA
Storage Temperature ( $T_{STG}$ )	-65°C to +150°C
Junction Temperature ( $T_J$ )	
CDIP	175°C
PDIP	140°C

**Note 1:** Absolute maximum ratings are those values beyond which damage to the device may occur. The databook specifications should be met, without exception, to ensure that the system design is reliable over its power supply, temperature, and output/input loading variables. National does not recommend operation of FACT™ circuits outside databook specifications.

### Recommended Operating Conditions

Supply Voltage ( $V_{CC}$ )	
*AC	2.0V to 6.0V
*ACT	4.5V to 5.5V
Input Voltage ( $V_I$ )	0V to $V_{CC}$
Output Voltage ( $V_O$ )	0V to $V_{CC}$
Operating Temperature ( $T_A$ )	
74AC/ACT	-40°C to +85°C
54AC/ACT	-55°C to +125°C
Minimum Input Edge Rate ( $\Delta V/\Delta t$ )	
*AC Devices	
$V_{IN}$ from 30% to 70% of $V_{CC}$	
$V_{CC}$ @ 3.3V, 4.5V, 5.5V	125 mV/ns
Minimum Input Edge Rate ( $\Delta V/\Delta t$ )	
*ACT Devices	
$V_{IN}$ from 0.8V to 2.0V	
$V_{CC}$ @ 4.5V, 5.5V	125 mV/ns

### DC Characteristics for \*AC Family Devices

Symbol	Parameter	$V_{CC}$ (V)	74AC		54AC	74AC		Units	Conditions
			$T_A = +25^\circ C$		$T_A = -55^\circ C$ to $+125^\circ C$	$T_A = -40^\circ C$ to $+85^\circ C$			
			Typ		Guaranteed Limits				
$V_{IH}$	Minimum High Level Input Voltage	3.0	1.5	2.1	2.1	2.1	2.1	V	$V_{OUT} = 0.1V$ or $V_{CC} - 0.1V$
		4.5	2.25	3.15	3.15	3.15	3.15		
		5.5	2.75	3.85	3.85	3.85	3.85		
$V_{IL}$	Maximum Low Level Input Voltage	3.0	1.5	0.9	0.9	0.9	0.9	V	$V_{OUT} = 0.1V$ or $V_{CC} - 0.1V$
		4.5	2.25	1.35	1.35	1.35	1.35		
		5.5	2.75	1.65	1.65	1.65	1.65		
$V_{OH}$	Minimum High Level Output Voltage	3.0	2.99	2.9	2.9	2.9	2.9	V	$I_{OUT} = -50 \mu A$
		4.5	4.49	4.4	4.4	4.4	4.4		
		5.5	5.49	5.4	5.4	5.4	5.4		
		3.0		2.56	2.4	2.46	2.46	V	* $V_{IN} = V_{IL}$ or $V_{IH}$ 12 mA $I_{OH} = -24$ mA -24 mA
		4.5		3.86	3.7	3.76	3.76		
		5.5		4.86	4.7	4.76	4.76		
$V_{OL}$	Maximum Low Level Output Voltage	3.0	0.002	0.1	0.1	0.1	0.1	V	$I_{OUT} = 50 \mu A$
		4.5	0.001	0.1	0.1	0.1	0.1		
		5.5	0.001	0.1	0.1	0.1	0.1		
		3.0		0.36	0.5	0.44	0.44	V	* $V_{IN} = V_{IL}$ or $V_{IH}$ 12 mA $I_{OL} = 24$ mA 24 mA
		4.5		0.36	0.5	0.44	0.44		
		5.5		0.36	0.5	0.44	0.44		
$I_{IN}$	Maximum Input Leakage Current	5.5		±0.1	±1.0	±1.0	±1.0	μA	$V_I = V_{CC}$ , GND

\*All outputs loaded; thresholds on input associated with output under test.

**Note:**  $I_{IN}$  and  $I_{CC}$  @ 3.0V are guaranteed to be less than or equal to the respective limit @ 5.5V  $V_{CC}$ .

$I_{CC}$  for 54AC @ 25°C is identical to 74AC @ 25°C.

### DC Characteristics for 'AC Family Devices (Continued)

Symbol	Parameter	V <sub>CC</sub> (V)	74AC		54AC		74AC		Units	Conditions
			T <sub>A</sub> = +25°C		T <sub>A</sub> = -55°C to +125°C		T <sub>A</sub> = -40°C to +85°C			
			Typ	Guaranteed Limits						
I <sub>OLD</sub>	†Minimum Dynamic Output Current	5.5				50		75	mA	V <sub>OLD</sub> = 1.65V Max
I <sub>OHD</sub>		5.5				-50		-75	mA	V <sub>OHD</sub> = 3.85V Min
I <sub>CC</sub>	Maximum Quiescent Supply Current	5.5		2.0		40.0		20.0	μA	V <sub>IN</sub> = V <sub>CC</sub> or GND

†Maximum test duration 2.0 ms, one output loaded at a time.

Note: I<sub>IN</sub> and I<sub>CC</sub> @ 3.0V are guaranteed to be less than or equal to the respective limit @ 5.5V V<sub>CC</sub>.

I<sub>CC</sub> for 54AC @ 25°C is identical to 74AC @ 25°C.

### DC Characteristics for 'ACT Family Devices

Symbol	Parameter	V <sub>CC</sub> (V)	74ACT		54ACT		74ACT		Units	Conditions
			T <sub>A</sub> = +25°C		T <sub>A</sub> = -55°C to +125°C		T <sub>A</sub> = -40°C to +85°C			
			Typ	Guaranteed Limits						
V <sub>IH</sub>	Minimum High Level Input Voltage	4.5	1.5	2.0		2.0		2.0	V	V <sub>OUT</sub> = 0.1V or V <sub>CC</sub> - 0.1V
		5.5	1.5	2.0		2.0		2.0		
V <sub>IL</sub>	Maximum Low Level Input Voltage	4.5	1.5	0.8		0.8		0.8	V	V <sub>OUT</sub> = 0.1V or V <sub>CC</sub> - 0.1V
		5.5	1.5	0.8		0.8		0.8		
V <sub>OH</sub>	Minimum High Level Output Voltage	4.5	4.49	4.4		4.4		4.4	V	I <sub>OUT</sub> = -50 μA
		5.5	5.49	5.4		5.4		5.4		
		4.5		3.86		3.70		3.76		
V <sub>OL</sub>	Maximum Low Level Output Voltage	4.5	0.001	0.1		0.1		0.1	V	I <sub>OUT</sub> = 50 μA
		5.5	0.001	0.1		0.1		0.1		
		4.5		0.36		0.50		0.44		
I <sub>IN</sub>	Maximum Input Leakage Current	5.5		±0.1		±1.0		±1.0	μA	V <sub>I</sub> = V <sub>CC</sub> , GND
		5.5	0.6			1.6		1.5		
I <sub>OLD</sub>	†Minimum Dynamic Output Current	5.5				50		75	mA	V <sub>OLD</sub> = 1.65V Max
I <sub>OHD</sub>		5.5				-50		-75	mA	V <sub>OHD</sub> = 3.85V Min
I <sub>CC</sub>	Maximum Quiescent Supply Current	5.5		2.0		40.0		20.0	μA	V <sub>IN</sub> = V <sub>CC</sub> or GND

\*All outputs loaded; thresholds on input associated with output under test.

†Maximum test duration 2.0 ms, one output loaded at a time

Note: I<sub>CC</sub> for 54ACT @ 25°C is identical to 74ACT @ 25°C.

8

**AC Electrical Characteristics:** See Section 2 for waveforms

Symbol	Parameter	V <sub>CC</sub> * (V)	74AC			54AC		74AC		Units	Fig. No.
			T <sub>A</sub> = +25°C C <sub>L</sub> = 50 pF			T <sub>A</sub> = -55°C to +125°C C <sub>L</sub> = 50 pF		T <sub>A</sub> = -40°C to +85°C C <sub>L</sub> = 50 pF			
			Min	Typ	Max	Min	Max	Min	Max		
t <sub>PLH</sub>	Propagation Delay	3.3 5.0	2.0 1.5	7.0 6.0	9.5 8.0	1.0 1.5	11.0 8.5	2.0 1.5	10.0 8.5	ns	2-3,4
t <sub>PHL</sub>	Propagation Delay	3.3 5.0	1.5 1.5	5.5 4.5	8.0 6.5	1.0 1.5	9.0 7.0	1.0 1.0	8.5 7.0	ns	2-3,4

\*Voltage Range 3.3 is 3.3V ±0.3V  
Voltage Range 5.0 is 5.0V ±0.5V

**AC Electrical Characteristics:** See Section 2 for waveforms

Symbol	Parameter	V <sub>CC</sub> * (V)	74ACT			54ACT		74ACT		Units	Fig. No.
			T <sub>A</sub> = +25°C C <sub>L</sub> = 50 pF			T <sub>A</sub> = -55°C to +125°C C <sub>L</sub> = 50 pF		T <sub>A</sub> = -40°C to +85°C C <sub>L</sub> = 50 pF			
			Min	Typ	Max	Min	Max	Min	Max		
t <sub>PLH</sub>	Propagation Delay	5.0	1.5	5.5	9.0	1.5	9.5	1.0	9.5	ns	2-3,4
t <sub>PHL</sub>	Propagation Delay	5.0	1.5	4.0	7.0	1.5	8.0	1.0	8.0	ns	2-3,4

Voltage Range 5.0 is 5.0V ±0.5V

**Capacitance**

Symbol	Parameter	Typ	Units	Conditions
C <sub>IN</sub>	Input Capacitance	4.5	pF	V <sub>CC</sub> = Open
C <sub>PD</sub>	Power Dissipation Capacitance	30.0	pF	V <sub>CC</sub> = 5.0V