

Description

Q-Tech's surface-mount QTCC570 oscillators consist of an IC 5Vdc, 3.3Vdc, 2.5Vdc, and 1.8Vdc clock square wave generator and a miniature strip AT quartz crystal built in a low profile ceramic package with gold plated contact pads.

Features

- ECCN: EAR99
- Broad frequency range from 1.544MHz to 190.000MHz
- Small footprint
- HCMOS logic
- 5.0Vdc, 3.3Vdc, 2.5Vdc, and 1.8Vdc supply
- Operating temperature -55°C to +125°C available
- Tri-State Output Standard
- Hermetically sealed ceramic package
- Fundamental and 3rd Overtone designs
- Military screening tests per MIL-PRF-55310 available
- Tape and reel packaging
- Lead Free, RoHS Compliant



Applications

- Designed to meet today's requirements for low voltage applications
- Gun launched munitions and systems
- Smart munitions
- Instrumentation
- Navigation
- Avionics
- Ethernet/SynchE
- SONET
- Microprocessor clock

Stock List

See all Miniature Oscillator products [IN STOCK](#)

Ordering is NOT limited to the IN STOCK list. Please consult with our sales managers to order custom frequencies.

Ordering Information

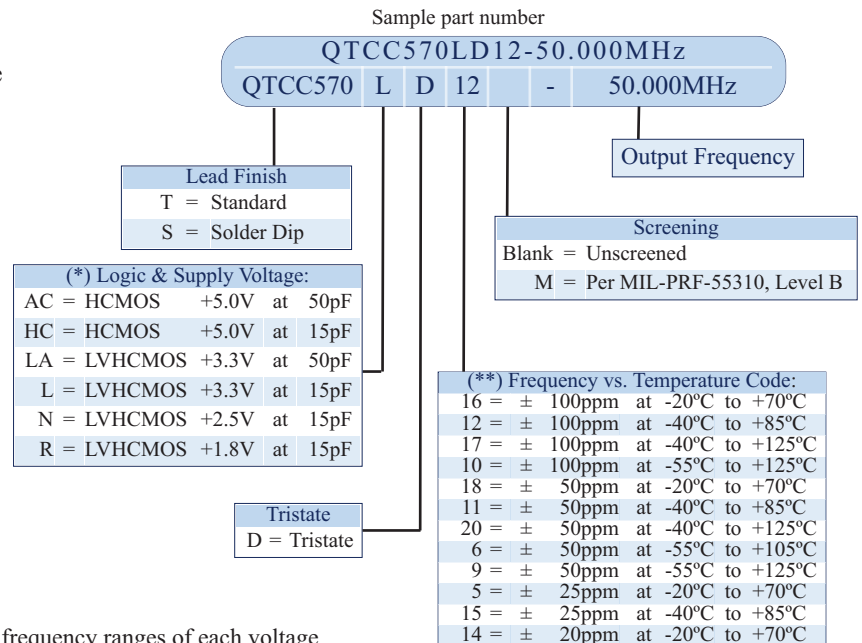

(*) See page 3 for frequency ranges of each voltage option.

(**) For codes 9 and 10, max frequency for 5V is 40MHz

Other Options Available For An Additional Charge

- Hot Solder Dip Sn60/Pb40 per MIL-PRF 55310

Specifications subject to change without prior notice.

Frequency stability vs. temperature codes may not be available in all frequencies.

For Non-Standard requirements, contact Q-Tech Corporation at Sales@Q-Tech.com

Package Outline and Pin Connections

Dimensions are in inches (mm)

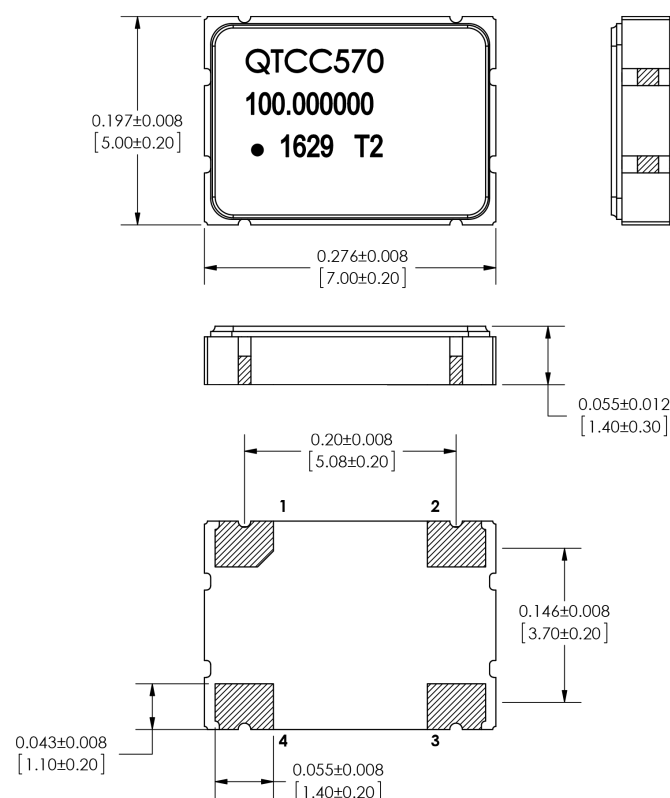

Pin No.	Function
1	TRISTATE
2	GND/CASE
3	OUTPUT
4	VDD

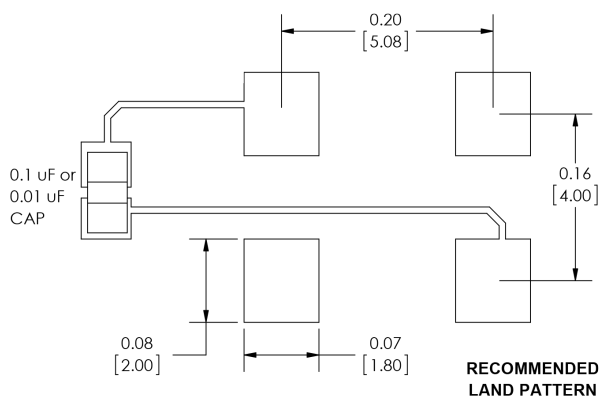

An external bypass capacitor 0.01μF is required between Vdd and GND

Marking

Line 1: QTCC570 (First 7 Characters of Description)
 Line 2: XXX.XXXXXX (9 or 10 Characters of Frequency in MHz including decimal)
 Line 3: Dot (Pin 1 Indicator) + Date code (YY/WW), Internal Traceability Code

Package Information

- Termination pads (4x), Electro nickel plating 1.27μm ~ 8.89μm typ., with gold 0.3μm ~ 1.0μm flash plate
- Weight: 0.15g typ., 2.0g max.

Electrical Characteristics

Parameters	QTCC570AC	QTCC570HC	QTCC570LA	QTCC570L	QTCC570N	QTCC570R
Output frequency range (Fo)	1.544MHz — 125.000MHz		1.544MHz — 190.000MHz			1.544MHz — 172.000MHz
Supply voltage (Vdd)	5.0Vdc ± 10%		3.3Vdc ± 10%		2.5Vdc ± 10%	
Maximum Applied Voltage (Vdd max.)	-0.7 to +7.0Vdc		-0.5 to +5.0Vdc			-0.5 to +3.6Vdc
Frequency stability (ΔF/ΔT)	See Part Number on Page 1					
Operating temperature (Topr)	See Part Number on Page 1					
Storage temperature (Tsto)	-62°C to + 125°C					
Operating supply current (No Load)	10 mA max. - ≤ 20MHz 30 mA max. - 20MHz ~ ≤ 50MHz 50 mA max. - 50MHz ~ ≤ 85MHz 60 mA max. - 85MHz ~ 125MHz		7 mA max. - ≤ 20MHz 20 mA max. - 20MHz ~ ≤ 50MHz 30 mA max. - 50MHz ~ ≤ 85MHz 50 mA max. - 85MHz ~ 190MHz		7 mA max. - ≤ 20MHz 15 mA max. - 20MHz ~ ≤ 50MHz 20 mA max. - 50MHz ~ ≤ 110MHz 30 mA max. - 110MHz ~ 190MHz	5 mA max. - ≤ 20MHz 15 mA max. - 20MHz ~ ≤ 70MHz 25 mA max. - 70MHz ~ ≤ 96MHz 30 mA max. - 96MHz ~ 172MHz
Symmetry (50% of output waveform)	45/55%					
Rise and Fall times	8 ns max. - ≤ 20MHz 5 ns max. - 20MHz ~ ≤ 50MHz 2 ns max. - 50MHz ~ 125MHz 7 ns max. - 50pF Load (20 ~ 40MHz)		6 ns max. - ≤ 20MHz 4 ns max. - 20MHz ~ ≤ 50MHz 3 ns max. - 50MHz ~ ≤ 90MHz 2 ns max. - 90MHz ~ 190MHz 7 ns max. - 50pF Load (<40MHz)		10 ns max. - ≤ 20MHz 6 ns max. - 20MHz ~ ≤ 50MHz 3 ns max. - 50MHz ~ ≤ 90MHz 2 ns max. - 90MHz ~ 190MHz	4 ns max. - ≤ 20MHz 4 ns max. - 20MHz ~ ≤ 50MHz 3 ns max. - 50MHz ~ ≤ 90MHz 2 ns max. - 90MHz ~ 172MHz
Output Load (Note 1)	50pF max.	15pF max.	50pF max.	15pF max.		
Start-up time (Tstup)	10ms max.					
Output voltage (Voh/Vol)	0.9Vdd min. / 0.1Vdd max.					
Output Current (Ioh/Iol)	± 16mA max.			± 8mA max.		
Enable/Disable function Pin 1	VIH ≥ 4.0V Active VIL ≤ 0.8V High Z		VIH ≥ 2.0V Active		VIH ≥ 1.75V Active VIL ≤ 0.5V High Z	
Phase noise typ. @ 44.736MHz	10Hz -83 dBc/Hz 100Hz -120 dBc/Hz 1kHz -150 dBc/Hz 10kHz -157 dBc/Hz 100kHz -162 dBc/Hz 1MHz -164 dBc/Hz 10MHz -165 dBc/Hz					
Aging	10 years aging included in Frequency Stability ±5ppm max. First Year ±2ppm max. Each Year Thereafter					

Note 1: 50pF Load is only available up to 50MHz

Output Waveform (Typical)

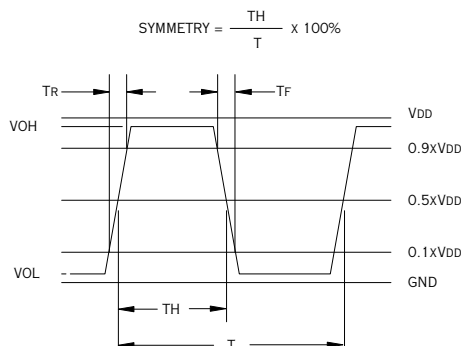

Reflow Profile

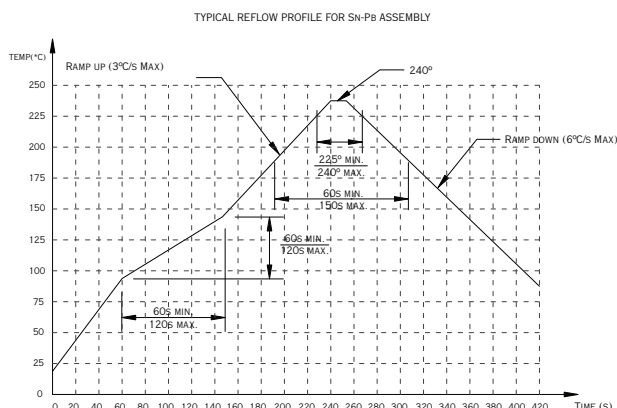

Test Circuit

TYPICAL TEST CIRCUIT FOR CMOS LOGIC

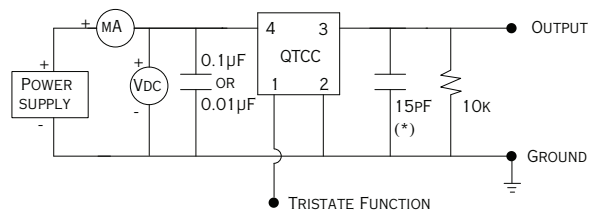

(* CL INCLUDES PROBE AND JIG CAPACITANCE)

The Tristate function on pin 1 has a built-in pull-up resistor so it can be left floating or tied to Vdd without deteriorating the electrical performance.

Embossed Tape and Reel Information

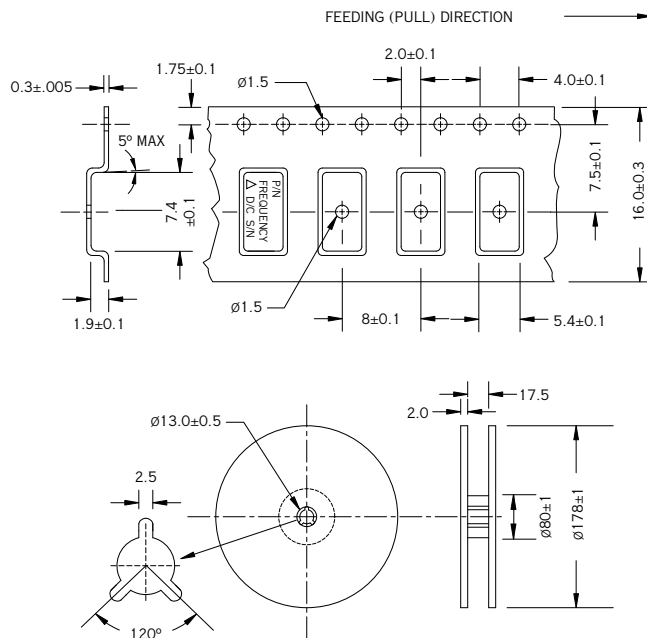

Dimensions are in mm. Tape is compliant to EIA-481-A.

Reel size (Diameter in mm)	Qty per reel (pcs)
178	1,000

Environmental and Mechanical Specifications

Environmental Test	Test Conditions
Temperature cycling	MIL-STD-883, Method 1010, Cond. B
Constant acceleration	MIL-STD-883, Method 2001, Cond. A, Y1
Seal: Fine and Gross Leak	MIL-STD-883, Method 1014, Cond. A and C
Vibration sinusoidal	MIL-STD-202, Method 204, Cond. D
Shock, non operating	MIL-STD-202, Method 213, Cond. I
Resistance to solder heat	MIL-STD-202, Method 210, Cond. B
Resistance to solvents	MIL-STD-202, Method 215
Solderability	MIL-STD-202, Method 208
ESD Classification	MIL-STD-883, Method 3015, Class 1
Moisture Sensitivity Level	J-STD-020, MSL=1



QTCC570 SERIES
LOW PROFILE 5 x 7mm MINIATURE SMD CRYSTAL OSCILLATORS
1.8, 2.5, 3.3 and 5.0Vdc - 1.544MHz to 190.000MHz

DCO	REV	REVISION SUMMARY	PAGE	DATE
6160	A	Add N and R logic options	1	3/6/17
		Add frequency vs temp code 14		
		Storage temp changed -55C to -62C	3	
		Period jitter changed from 40ps max. to the values now seen in table		
		Add N and R Electrical Characteristics	3	
6727	B	Revise Rise and Fall times for 50pF load	3	4/24/17
		Fix Tape/Reel dimensions	4	
		Revise Aging	3	
		Removed jitter information and add phase noise data	3	
9770	C	Revise frequency limits for 50pF load	3	04/24/2019
		Lower max frequency for 5.0V parts to 40.000MHz for temperatures of -55 to +125°C	1	