

# SN54ALS541, SN74ALS540, SN74ALS541 OCTAL BUFFERS AND LINE DRIVERS WITH 3-STATE OUTPUTS

SDAS025C – APRIL 1982 – REVISED JANUARY 1995

- 3-State Outputs Drive Bus Lines or Buffer Memory Address Registers
- pnp Inputs Reduce dc Loading
- Data Flow-Through Pinout (All Inputs on Opposite Side From Outputs)
- Package Options Include Plastic Small-Outline (DW) Packages, Ceramic Chip Carriers (FK), and Standard Plastic (N) and Ceramic (J) 300-mil DIPs

## description

These octal buffers and line drivers are designed to have the performance of the popular SN54ALS240A/SN74ALS240A series and, at the same time, offer a pinout with inputs and outputs on opposite sides of the package. This arrangement greatly facilitates printed-circuit-board layout.

The 3-state control gate is a 2-input NOR such that if either output-enable ( $\overline{OE1}$  or  $\overline{OE2}$ ) input is high, all eight outputs are in the high-impedance state.

The SN74ALS540 provides inverted data. The ALS541 provide true data at the outputs.

The -1 versions of SN74ALS540 and SN74ALS541 are identical to the standard versions, except that the recommended maximum  $I_{OL}$  is increased to 48 mA. There is no -1 version of the SN54ALS541.

The SN54ALS541 is characterized for operation over the full military temperature range of  $-55^{\circ}\text{C}$  to  $125^{\circ}\text{C}$ . The SN74ALS540 and SN74ALS541 are characterized for operation from  $0^{\circ}\text{C}$  to  $70^{\circ}\text{C}$ .

SN54ALS541 . . . J PACKAGE  
SN74ALS540, SN74ALS541 . . . DW OR N PACKAGE  
(TOP VIEW)

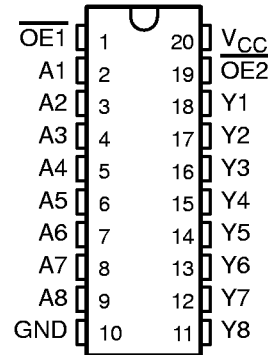

SN54ALS541 . . . FK PACKAGE  
(TOP VIEW)

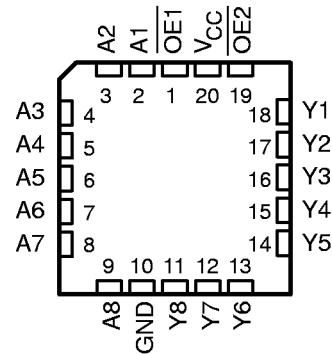

# SN54ALS541, SN74ALS540, SN74ALS541 OCTAL BUFFERS AND LINE DRIVERS WITH 3-STATE OUTPUTS

SDAS025C – APRIL 1982 – REVISED JANUARY 1995

## logic symbols†

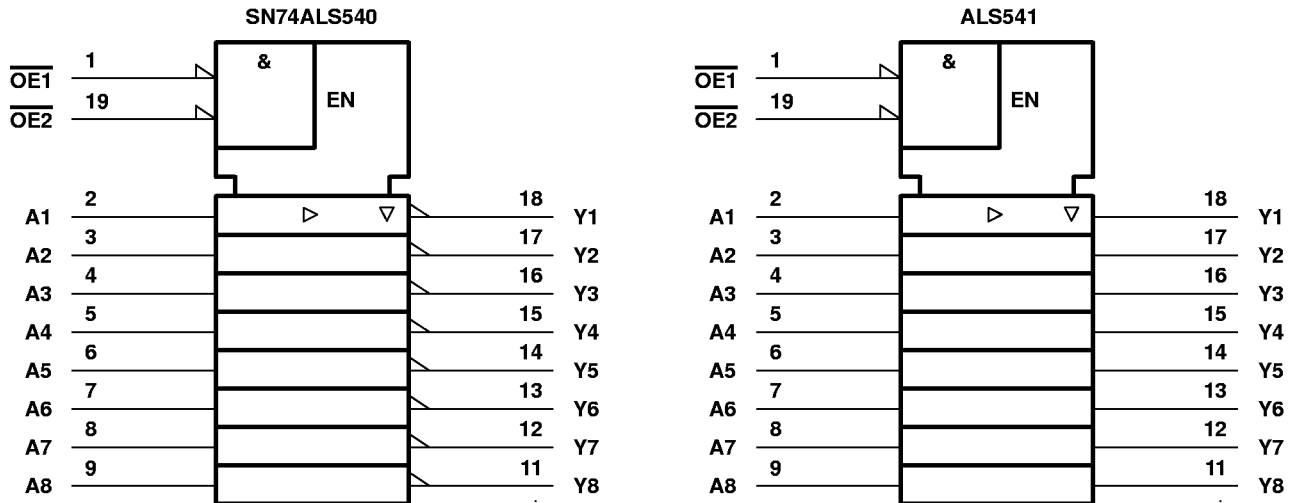

† These symbols are in accordance with ANSI/IEEE Std 91-1984 and IEC Publication 617-12.

## logic diagrams (positive logic)

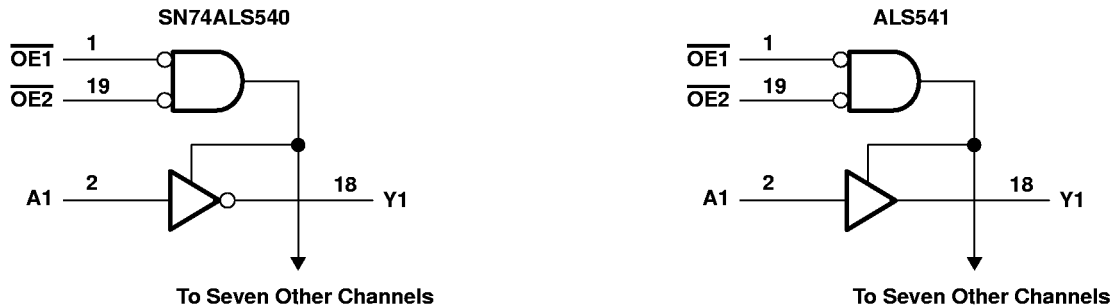

## absolute maximum ratings over operating free-air temperature range (unless otherwise noted)‡

Supply voltage, $V_{CC}$ .....	7 V
Input voltage, $V_I$ .....	7 V
Voltage applied to a disabled 3-state output .....	5.5 V
Operating free-air temperature range, $T_A$ : SN54ALS541 .....	-55°C to 125°C
SN74ALS540, SN74ALS541 .....	0°C to 70°C
Storage temperature range .....	-65°C to 150°C

‡ Stresses beyond those listed under "absolute maximum ratings" may cause permanent damage to the device. These are stress ratings only, and functional operation of the device at these or any other conditions beyond those indicated under "recommended operating conditions" is not implied. Exposure to absolute-maximum-rated conditions for extended periods may affect device reliability.

# SN54ALS541, SN74ALS540, SN74ALS541 OCTAL BUFFERS AND LINE DRIVERS WITH 3-STATE OUTPUTS

SDAS025C – APRIL 1982 – REVISED JANUARY 1995

## recommended operating conditions

		SN54ALS541			SN74ALS540 SN74ALS541			UNIT
		MIN	NOM	MAX	MIN	NOM	MAX	
V <sub>CC</sub>	Supply voltage	4.5	5	5.5	4.5	5	5.5	V
V <sub>IH</sub>	High-level input voltage	2			2			V
V <sub>IL</sub>	Low-level input voltage			0.7			0.8	V
I <sub>OH</sub>	High-level output current			-12			-15	mA
I <sub>OL</sub>	Low-level output current			12			24	mA
							48†	
T <sub>A</sub>	Operating free-air temperature	-55		125	0		70	°C

† Applies only to the -1 version and only if V<sub>CC</sub> is between 4.75 V and 5.25 V

## electrical characteristics over recommended operating free-air temperature range (unless otherwise noted)

PARAMETER	TEST CONDITIONS	SN54ALS541			SN74ALS540 SN74ALS541			UNIT
		MIN	TYP‡	MAX	MIN	TYP‡	MAX	
V <sub>IK</sub>	V <sub>CC</sub> = 4.5 V, I <sub>I</sub> = -18 mA			-1.2			-1.2	V
V <sub>OH</sub>	V <sub>CC</sub> = 4.5 V to 5.5 V, I <sub>OH</sub> = -0.4 mA	V <sub>CC</sub> - 2			V <sub>CC</sub> - 2			V
	V <sub>CC</sub> = 4.5 V	I <sub>OH</sub> = -3 mA	2.4	3.2	2.4	3.2		
		I <sub>OH</sub> = -12 mA	2					
V <sub>OL</sub>	V <sub>CC</sub> = 4.5 V	I <sub>OH</sub> = -15 mA				2		V
		I <sub>OL</sub> = 12 mA	0.25	0.4	0.25	0.4		
		I <sub>OL</sub> = 24 mA				0.35	0.5	
		I <sub>OL</sub> = 48 mA†				0.35	0.5	
I <sub>OZH</sub>	V <sub>CC</sub> = 5.5 V, V <sub>O</sub> = 2.7 V				20			μA
I <sub>OZL</sub>	V <sub>CC</sub> = 5.5 V, V <sub>O</sub> = 0.4 V				-20			μA
I <sub>I</sub>	V <sub>CC</sub> = 5.5 V, V <sub>I</sub> = 7 V				0.1			mA
I <sub>IH</sub>	V <sub>CC</sub> = 5.5 V, V <sub>I</sub> = 2.7 V				20			μA
I <sub>IL</sub>	V <sub>CC</sub> = 5.5 V, V <sub>I</sub> = 0.4 V				-0.2			mA
I <sub>O§</sub>	V <sub>CC</sub> = 5.5 V, V <sub>O</sub> = 2.25 V	-20		-112	-30		-112	mA
I <sub>CC</sub>	SN74ALS540	V <sub>CC</sub> = 5.5 V	Outputs high	5	10	5	10	mA
			Outputs low	13	22	13	22	
			Outputs disabled	11	19	11	19	
	ALS541	V <sub>CC</sub> = 5.5 V	Outputs high	6	14	6	14	
			Outputs low	15	25	15	25	
			Outputs disabled	13.5	32	13.5	22	

† Applies only to the -1 version and only if V<sub>CC</sub> is between 4.75 V and 5.25 V

‡ All typical values are at V<sub>CC</sub> = 5 V, T<sub>A</sub> = 25°C.

§ The output conditions have been chosen to produce a current that closely approximates one half of the true short-circuit output current, I<sub>OS</sub>.



# SN54ALS541, SN74ALS540, SN74ALS541 OCTAL BUFFERS AND LINE DRIVERS WITH 3-STATE OUTPUTS

SDAS025C – APRIL 1982 – REVISED JANUARY 1995

## switching characteristics (see Figure 1)

PARAMETER	FROM (INPUT)	TO (OUTPUT)	$V_{CC} = 4.5 \text{ V to } 5.5 \text{ V},$ $C_L = 50 \text{ pF},$ $R_1 = 500 \Omega,$ $R_2 = 500 \Omega,$ $T_A = \text{MIN to MAX}^\dagger$						UNIT
			SN54ALS541		SN74ALS540		SN74ALS541		
			MIN	MAX	MIN	MAX	MIN	MAX	
$t_{PLH}$	A	Y	4	17	2	12	4	14	ns
$t_{PHL}$			2	14	2	9	2	10	
$t_{PZH}$	$\overline{OE}$	Y	5	18	5	15	5	15	ns
$t_{PZL}$			8	28	8	20	8	20	
$t_{PHZ}$	$\overline{OE}$	Y	1	12	1	10	1	10	ns
$t_{PLZ}$			2	14	2	12	2	12	

<sup>†</sup> For conditions shown as MIN or MAX, use the appropriate value specified under recommended operating conditions.

# SN54ALS541, SN74ALS540, SN74ALS541 OCTAL BUFFERS AND LINE DRIVERS WITH 3-STATE OUTPUTS

SDAS025C – APRIL 1982 – REVISED JANUARY 1995

## PARAMETER MEASUREMENT INFORMATION SERIES 54ALS/74ALS AND 54AS/74AS DEVICES

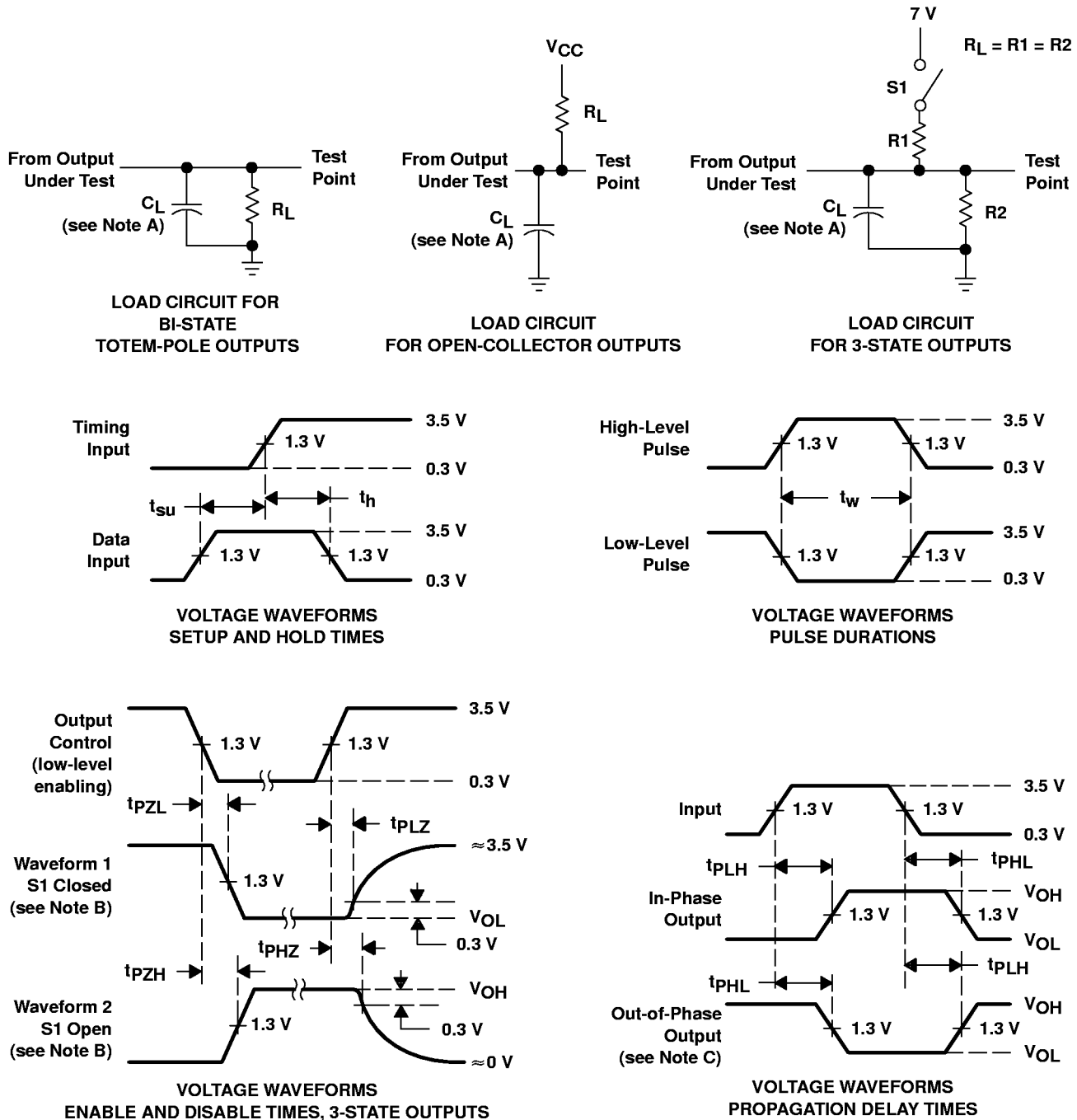

- NOTES: A.  $C_L$  includes probe and jig capacitance.  
 B. Waveform 1 is for an output with internal conditions such that the output is low except when disabled by the output control. Waveform 2 is for an output with internal conditions such that the output is high except when disabled by the output control.  
 C. When measuring propagation delay items of 3-state outputs, switch S1 is open.  
 D. All input pulses have the following characteristics:  $PRR \leq 1$  MHz,  $t_r = t_f = 2$  ns, duty cycle = 50%.  
 E. The outputs are measured one at a time with one transition per measurement.

Figure 1. Load Circuits and Voltage Waveforms

## **IMPORTANT NOTICE**

Texas Instruments (TI) reserves the right to make changes to its products or to discontinue any semiconductor product or service without notice, and advises its customers to obtain the latest version of relevant information to verify, before placing orders, that the information being relied on is current.

TI warrants performance of its semiconductor products and related software to the specifications applicable at the time of sale in accordance with TI's standard warranty. Testing and other quality control techniques are utilized to the extent TI deems necessary to support this warranty. Specific testing of all parameters of each device is not necessarily performed, except those mandated by government requirements.

Certain applications using semiconductor products may involve potential risks of death, personal injury, or severe property or environmental damage ("Critical Applications").

**TI SEMICONDUCTOR PRODUCTS ARE NOT DESIGNED, INTENDED, AUTHORIZED, OR WARRANTED TO BE SUITABLE FOR USE IN LIFE-SUPPORT APPLICATIONS, DEVICES OR SYSTEMS OR OTHER CRITICAL APPLICATIONS.**

Inclusion of TI products in such applications is understood to be fully at the risk of the customer. Use of TI products in such applications requires the written approval of an appropriate TI officer. Questions concerning potential risk applications should be directed to TI through a local SC sales office.

In order to minimize risks associated with the customer's applications, adequate design and operating safeguards should be provided by the customer to minimize inherent or procedural hazards.

TI assumes no liability for applications assistance, customer product design, software performance, or infringement of patents or services described herein. Nor does TI warrant or represent that any license, either express or implied, is granted under any patent right, copyright, mask work right, or other intellectual property right of TI covering or relating to any combination, machine, or process in which such semiconductor products or services might be or are used.