

LOW POWER QUAD CMOS VOLTAGE COMPARATORS

- WIDE SINGLE SUPPLY RANGE OR DUAL SUPPLIES 3V TO 16V OR $\pm 1.5V$ to $\pm 8V$
- VERY LOW SUPPLY CURRENT : 0.1mA/COMP INDEPENDENT OF SUPPLY VOLTAGE
- EXTREMELY LOW INPUT BIAS CURRENT : 1pA TYP
- EXTREMELY LOW INPUT OFFSET CURRENT : 1pA TYP
- LOW INPUT OFFSET VOLTAGE
- INPUT COMMON-MODE VOLTAGE RANGE INCLUDES GND
- LOW OUTPUT SATURATION VOLTAGE 150mV TYP
- OUTPUT COMPATIBLE WITH TTL, MOS AND CMOS
- HIGH INPUT IMPEDANCE $10^{12}\Omega$ TYP
- FAST RESPONSE TIME : 200ns TYP FOR TTL LEVEL INPUT STEP

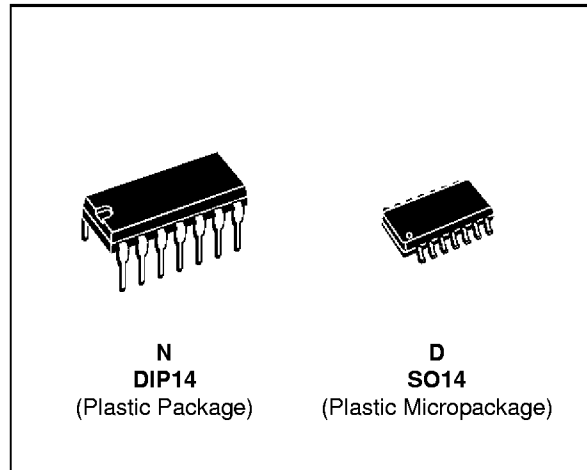

ORDER CODES

Part Number	Temperature Range	Package	
		N	D
TS374C	0°C, +70°C	●	●
TS374I	-40°C, +125°C	●	●
TS374M	-55°C, +125°C	●	●

Example : TS374CN

PIN CONNECTIONS (top view)

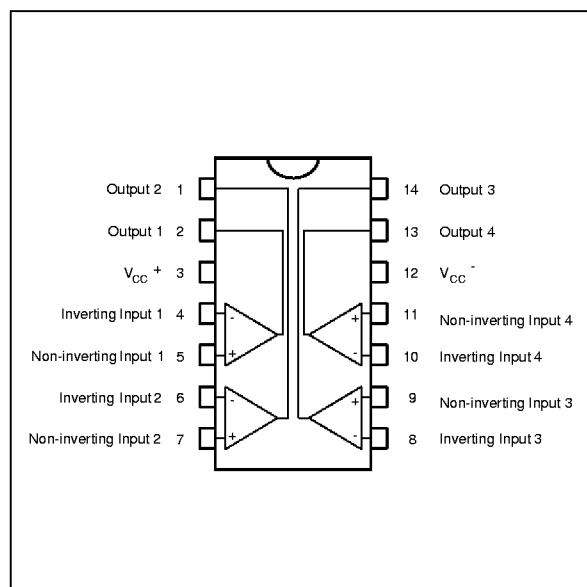

DESCRIPTION

These devices consist of four independent precision voltage comparators, designed to operate with single or dual supplies.

These differential comparators use the SGS-THOMSON silicon lin MOS process giving them an excellent consumption-speed ratio.

These devices are ideally suited for low consumption applications.

SCHEMATIC DIAGRAM (for 1/4 TS374)

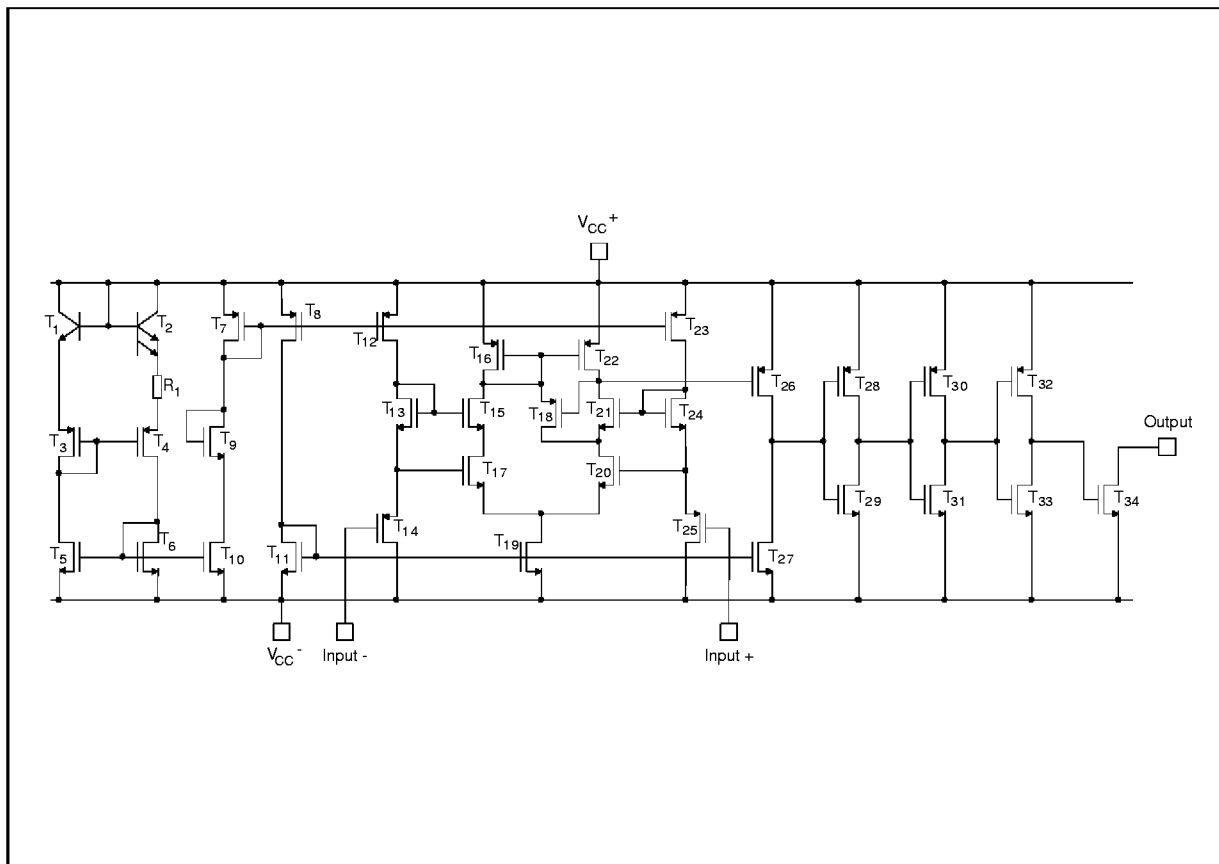

MAXIMUM RATINGS

Symbol	Parameter	Value	Unit
V_{CC}^+	Supply Voltage - (note 1)	18	V
V_{id}	Differential Input Voltage - (note 2)	± 18	V
V_i	Input Voltage - (note 3)	18	V
V_o	Output Voltage	18	V
I_o	Output Current	20	mA
	Duration of Output Short-Circuit to GND - (note 4)	Infinite	
T_{oper}	Operating Free-Air Temperature Range	0 to +70 -40 to +125 -55 to +125	$^{\circ}C$
		TS374C TS374I TS374M	
T_{stg}	Storage Temperature Range	-65 to +150	$^{\circ}C$

- Notes :**
1. All voltage values, except differential voltage, are with respect to network ground terminal.
 2. Differential voltages are the non-inverting input terminal with respect to the inverting input terminal.
 3. The magnitude of the input and the output voltages must never exceed the magnitude of the positive supply voltage.
 4. Short circuit from outputs to V_{CC}^+ can cause excessive heating and eventual destruction.

OPERATING CONDITIONS

Symbol	Parameter	Value	Unit
V_{CC}^+	Supply Voltage	3 to 16	V
V_{icm}	Common Mode Input Voltage Range	0 to $V_{CC}^+ - 1.5$	V

ELECTRICAL CHARACTERISTICS
 $V_{CC}^+ = 5V$, $V_{CC}^- = 0V$, $T_{amb} = 25^\circ C$ (unless otherwise specified)

Symbol	Parameter	Min.	Typ.	Max.	Unit
V_{io}	Input Offset Voltage ($V_{ic} = V_{icm\ min.}$) - (note 1) $T_{amb} = 25^\circ C$ $T_{min.} \leq T_{amb} \leq T_{max.}$		2	10 12	mV
I_{io}	Input Offset Current - (note 2) $T_{amb} = 25^\circ C$ $T_{min.} \leq T_{amb} \leq T_{max.}$		1	100 200	pA
I_{ib}	Input Bias Current - (note 2) $T_{amb} = 25^\circ C$ $T_{min.} \leq T_{amb} \leq T_{max.}$		1	150 300	pA
V_{icm}	Input Common Mode Voltage Range $T_{amb} = 25^\circ C$ $T_{min.} \leq T_{amb} \leq T_{max.}$				V
I_{OH}	High Level Output Current ($V_{id} = 1V$) $T_{amb} = 25^\circ C$ $T_{min.} \leq T_{amb} \leq T_{max.}$		0.1	1	nA μA
V_{OL}	Low Level Output Voltage ($V_{id} = -1V$, $I_{OL} = 4mA$) $T_{amb} = 25^\circ C$ $T_{min.} \leq T_{amb} \leq T_{max.}$		100	400 700	mV
I_{OL}	Low Level Output Current ($V_{id} = -1V$, $V_{OL} = 1.5V$)	6	45		mA
I_{CC}	Supply Current (4 comparators) ($V_{id} = +1V$, no load)		0.6	1	mA

SWITCHING CHARACTERISTICS ($V_{CC}^+ = 5V$, $T_{amb} = 25^\circ C$)

Symbol	Parameter	Min.	Typ.	Max.	Unit
t_{re}	Response Time ($R_L = 5.1k\Omega$ connected to 5V, $C_L = 15pF$ - (note 3) • 100mV input step with 5mV overdrive • TTL level input step		600 200		ns

- Notes :
1. The specified offset voltage is the maximum value required to drive the output down to 400mV or up to 4V with $R_L = 100k\Omega$ to V_{CC}^+ .
 2. Maximum values including unavoidable inaccuracies of the industrial test.
 3. The response time which is specified is the interval between the input signal and the instant when the output signal crosses 1.4V.

PACKAGE MECHANICAL DATA
14 PINS - PLASTIC DIP

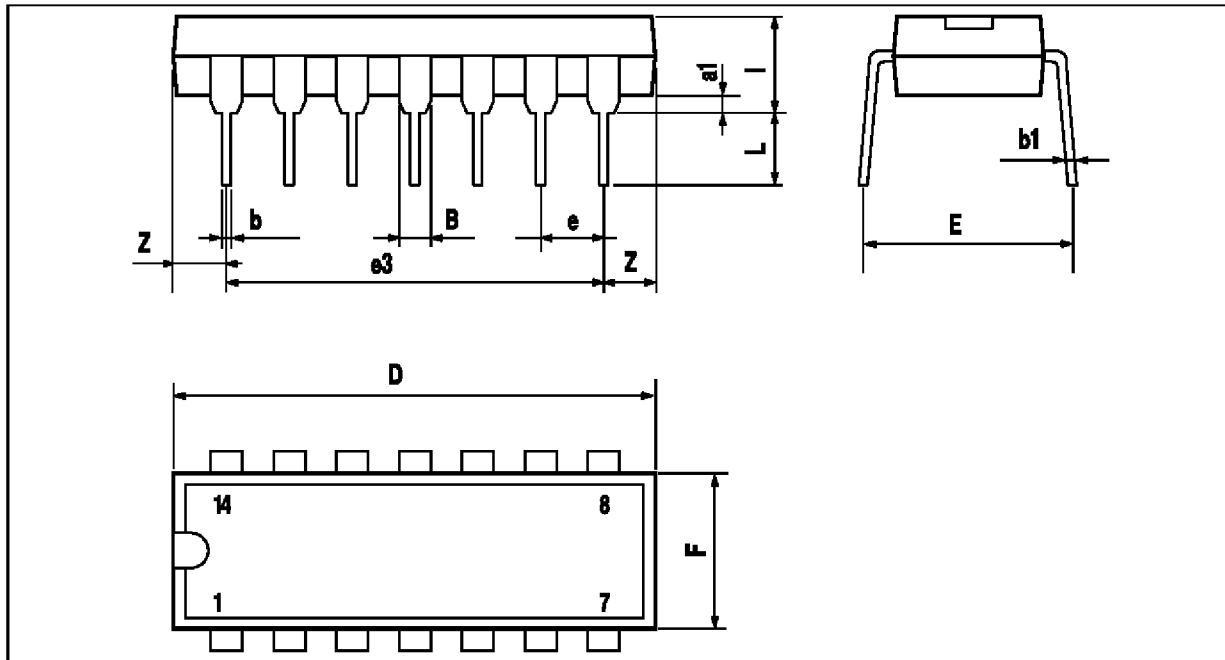

Dimensions	Millimeters			Inches		
	Min.	Typ.	Max.	Min.	Typ.	Max.
a1	0.51			0.020		
B	1.39		1.65	0.055		0.065
b		0.5			0.020	
b1		0.25			0.010	
D			20			0.787
E		8.5			0.335	
e		2.54			0.100	
e3		15.24			0.600	
F			7.1			0.280
i			5.1			0.201
L		3.3			0.130	
Z	1.27		2.54	0.050		0.100

PACKAGE MECHANICAL DATA
14 PINS - PLASTIC MICROPACKAGE (SO)

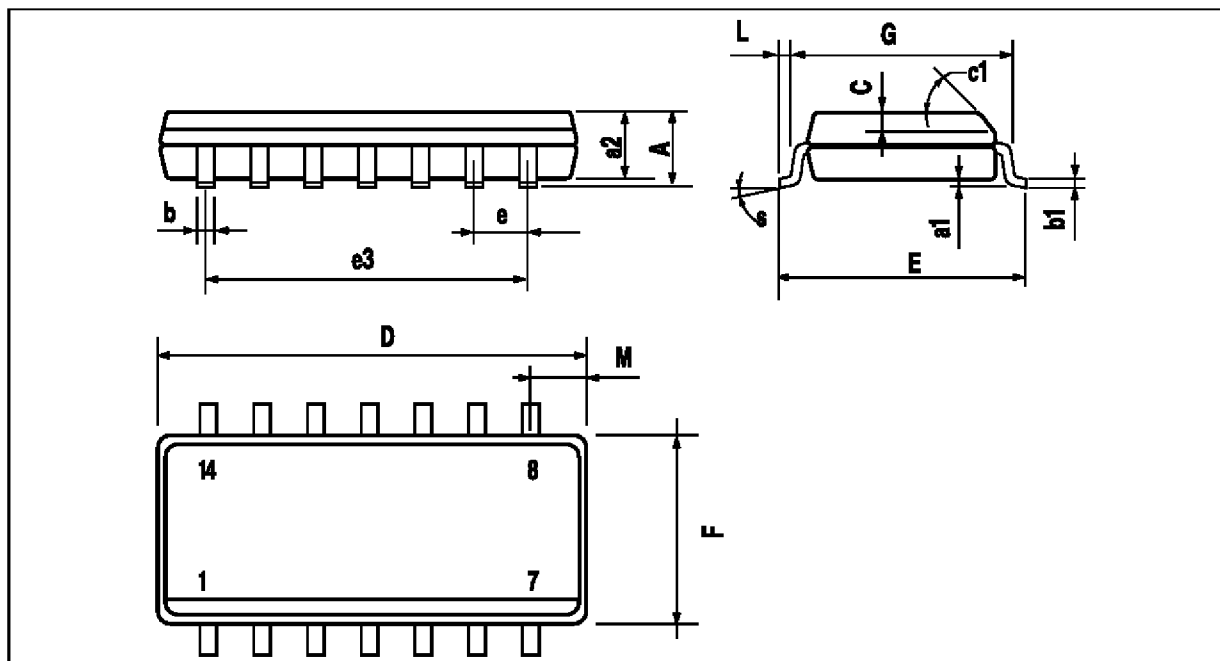

PM-SO14LEPS

Dimensions	Millimeters			Inches		
	Min.	Typ.	Max.	Min.	Typ.	Max.
A			1.75			0.069
a1	0.1		0.2	0.004		0.008
a2			1.6			0.063
b	0.35		0.46	0.014		0.018
b1	0.19		0.25	0.007		0.010
C		0.5			0.020	
c1	45° (typ.)					
D	8.55		8.75	0.336		0.334
E	5.8		6.2	0.228		0.244
e		1.27			0.050	
e3		7.62			0.300	
F	3.8		4.0	0.150		0.157
G	4.6		5.3	0.181		0.208
L	0.5		1.27	0.020		0.050
M			0.68			0.027
S	8° (max.)					

SO14.TBL

Information furnished is believed to be accurate and reliable. However, SGS-THOMSON Microelectronics assumes no responsibility for the consequences of use of such information nor for any infringement of patents or other rights of third parties which may result from its use. No license is granted by implication or otherwise under any patent or patent rights of SGS-THOMSON Microelectronics. Specification mentioned in this publication are subject to change without notice. This publication supersedes and replaces all information previously supplied. SGS-THOMSON Microelectronics products are not authorized for use as critical components in life support devices or systems without express written approval of SGS-THOMSON Microelectronics.

© 1997 SGS-THOMSON Microelectronics – Printed in Italy – All Rights Reserved

SGS-THOMSON Microelectronics GROUP OF COMPANIES

Australia - Brazil - Canada - China - France - Germany - Hong Kong - Italy - Japan - Korea - Malaysia - Malta - Morocco
The Netherlands - Singapore - Spain - Sweden - Switzerland - Taiwan - Thailand - United Kingdom - U.S.A.

ORDER CODE :