

# TYPES SN54298, SN54LS298, SN74298, SN74LS298 QUADRUPLE 2-INPUT MULTIPLEXERS WITH STORAGE

BULLETIN NO. DL-S 7611747, MARCH 1974—REVISED OCTOBER 1976

- **Selects One of Two 4-Bit Data Sources and Stores Data Synchronously with System Clock**
- **Applications:**  
Dual Source for Operands and Constants in Arithmetic Processor; Can Release Processor Register Files for Acquiring New Data

Implement Separate Registers Capable of Parallel Exchange of Contents Yet Retain External Load Capability

Universal Type Register for Implementing Various Shift Patterns; Even Has Compound Left-Right Capabilities

**description**

These monolithic quadruple two-input multiplexers with storage provide essentially the equivalent functional capabilities of two separate MSI functions (SN54157/SN74157 or SN54LS157/SN74LS157 and SN54175/SN74175 or SN54LS175/SN74LS175) in a single 16-pin package.

When the word-select input is low, word 1 (A1, B1, C1, D1) is applied to the flip-flops. A high input to word select will cause the selection of word 2 (A2, B2, C2, D2). The selected word is clocked to the output terminals on the negative-going edge of the clock pulse.

Typical power dissipation is 195 milliwatts for the '298 and 65 milliwatts for the 'LS298. SN54298 and SN54LS298 are characterized for operation over the full military temperature range of -55°C to 125°C; SN74298 and SN74LS298 are characterized for operation from 0°C to 70°C.

**FUNCTION TABLE**

INPUTS		OUTPUTS			
WORD SELECT	CLOCK	Q <sub>A</sub>	Q <sub>B</sub>	Q <sub>C</sub>	Q <sub>D</sub>
L	↓	a1	b1	c1	d1
H	↓	a2	b2	c2	d2
X	H	Q <sub>A0</sub>	Q <sub>B0</sub>	Q <sub>C0</sub>	Q <sub>D0</sub>

H = high level (steady state)  
L = low level (steady state)  
X = Irrelevant (any input, including transitions)  
↓ = transition from high to low level  
a1, a2, etc. = the level of steady-state input at A1, A2, etc.  
Q<sub>A0</sub>, Q<sub>B0</sub>, etc. = the level of Q<sub>A</sub>, Q<sub>B</sub>, etc. entered on the most-recent ↓ transition of the clock input.

SN54298, SN54LS298 ... J OR W PACKAGE  
SN74298, SN74LS298 ... J OR N PACKAGE  
(TOP VIEW)

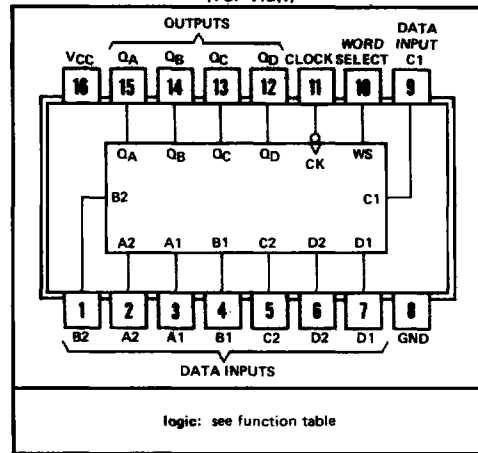

**functional block diagram**

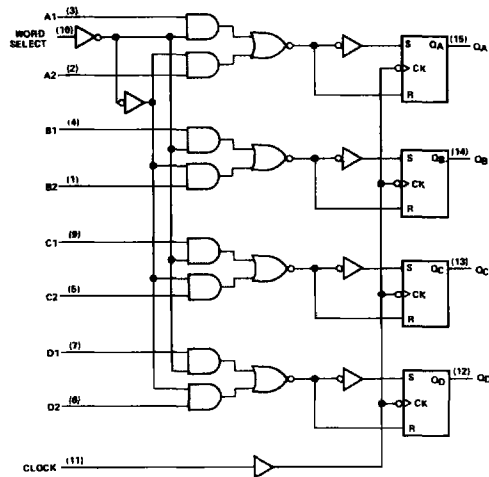

⚡ ... Dynamic input activated by a transition from a high level to a low level

# TYPES SN54298, SN54LS298, SN74298, SN74LS298 QUADRUPLE 2-INPUT MULTIPLEXERS WITH STORAGE

REVISED OCTOBER 1976

schematics of inputs and outputs

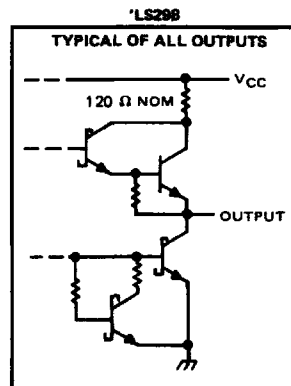
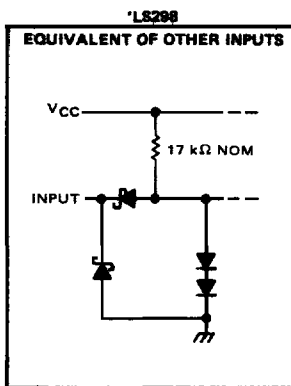
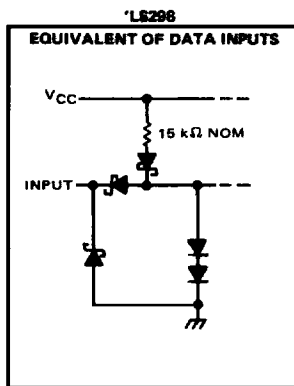
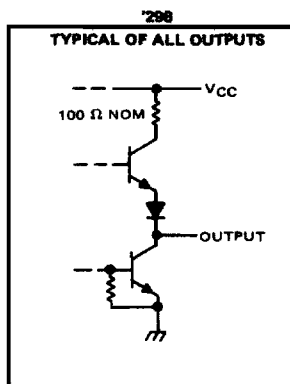
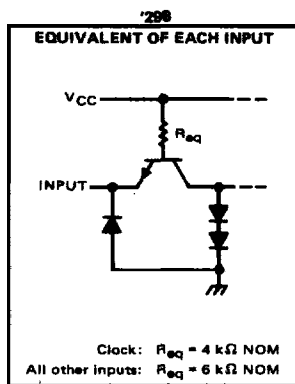

# TYPES SN54298, SN74298

## QUADRUPLE 2-INPUT MULTIPLEXERS WITH STORAGE

absolute maximum ratings over operating free-air temperature range (unless otherwise noted)

Supply voltage, $V_{CC}$ (see Note 1)	7 V
Input voltage	5.5 V
Operating free-air temperature range: SN54298	-55°C to 125°C
SN74298	0°C to 70°C
Storage temperature	-65°C to 150°C

NOTE 1: Voltage values are with respect to network ground terminal.

recommended operating conditions

	SN54298			SN74298			UNIT
	MIN	NOM	MAX	MIN	NOM	MAX	
Supply voltage, $V_{CC}$	4.5	5	5.5	4.75	5	5.25	V
High-level output current, $I_{OH}$	-800			-800			$\mu$ A
Low-level output current, $I_{OL}$	16			16			mA
Width of clock pulse, high or low level, $t_w$	20			20			ns
Setup time, $t_{su}$	Data	15		15		ns	
	Word select	25		25			
Hold time, $t_h$	Data	5		5		ns	
	Word select	0		0			
Operating free-air temperature, $T_A$	-55		125	0		70	°C

electrical characteristics over recommended operating free-air temperature range (unless otherwise noted)

PARAMETER	TEST CONDITIONS†	MIN	TYP‡	MAX	UNIT
$V_{IH}$ High-level input voltage		2			V
$V_{IL}$ Low-level input voltage				0.8	V
$V_{IK}$ Input clamp voltage	$V_{CC} = \text{MIN}$ , $I_I = -12 \text{ mA}$			-1.5	V
$V_{OH}$ High-level output voltage	$V_{CC} = \text{MIN}$ , $V_{IH} = 2 \text{ V}$ , $V_{IL} = 0.8 \text{ V}$ , $I_{OH} = -800 \mu\text{A}$	2.4	3.2		V
$V_{OL}$ Low-level output voltage	$V_{CC} = \text{MIN}$ , $V_{IH} = 2 \text{ V}$ , $V_{IL} = 0.8 \text{ V}$ , $I_{OL} = 16 \text{ mA}$			0.4	V
$I_I$ Input current at maximum input voltage	$V_{CC} = \text{MAX}$ , $V_I = 5.5 \text{ V}$			1	mA
$I_{IH}$ High-level input current	$V_{CC} = \text{MAX}$ , $V_I = 2.4 \text{ V}$			40	$\mu$ A
$I_{IL}$ Low-level input current	$V_{CC} = \text{MAX}$ , $V_I = 0.4 \text{ V}$			-1.6	mA
$I_{OS}$ Short-circuit output current§	$V_{CC} = \text{MAX}$	SN54298	-20		mA
		SN74298	-18		
$I_{CC}$ Supply current	$V_{CC} = \text{MAX}$ , See Note 2	39		65	mA

†For conditions shown as MIN or MAX, use the appropriate value specified under recommended operating conditions.

‡All typical values are at  $V_{CC} = 5 \text{ V}$ ,  $T_A = 25^\circ\text{C}$ .

§Not more than one output should be shorted at a time.

NOTE 2: With all outputs open and all inputs except clock low,  $I_{CC}$  is measured after applying a momentary 4.5 V, followed by ground, to the clock input.

switching characteristics,  $V_{CC} = 5 \text{ V}$ ,  $T_A = 25^\circ\text{C}$

PARAMETER	TEST CONDITIONS	MIN	TYP	MAX	UNIT
$t_{PLH}$ Propagation delay time, low-to-high-level output	$C_L = 15 \text{ pF}$ , $R_L = 400 \Omega$ ,	18		27	ns
$t_{PHL}$ Propagation delay time, high-to-low-level output	See Note 3	21		32	

NOTE 3: Load circuit and waveforms are shown on page 3-10.

# TYPES SN54LS298, SN74LS298

## QUADRUPLE 2-INPUT MULTIPLEXERS WITH STORAGE

REVISED OCTOBER 1976

absolute maximum ratings over operating free-air temperature range (unless otherwise noted)

Supply voltage, $V_{CC}$ (see Note 1)	7 V
Input voltage	7 V
Operating free-air temperature range: SN54LS298	-55°C to 125°C
SN74LS298	0°C to 70°C
Storage temperature range	-65°C to 150°C

NOTE 1: Voltage values are with respect to network ground terminal.

recommended operating conditions

	SN54LS298			SN74LS298			UNIT
	MIN	NOM	MAX	MIN	NOM	MAX	
Supply voltage, $V_{CC}$	4.5	5	5.5	4.75	5	5.25	V
High-level output current, $I_{OH}$			-400			-400	$\mu$ A
Low-level output current, $I_{OL}$			4			8	mA
Width of clock pulse, high or low level, $t_W$	20			20			ns
Setup time, $t_{SU}$	Data	15		15			ns
	Word select	25		25			
Hold time, $t_H$	Data	5		5			ns
	Word select	0		0			
Operating free-air temperature, $T_A$	-55		125	0		70	°C

electrical characteristics over recommended operating free-air temperature range (unless otherwise noted)

PARAMETER	TEST CONDITIONS <sup>†</sup>	SN54LS298			SN74LS298			UNIT
		MIN	TYP <sup>‡</sup>	MAX	MIN	TYP <sup>‡</sup>	MAX	
$V_{IH}$ High-level input voltage		2			2			V
$V_{IL}$ Low-level input voltage				0.7			0.8	V
$V_{IK}$ Input clamp voltage	$V_{CC} = \text{MIN}$ , $I_I = -18 \text{ mA}$			-1.5			-1.5	V
$V_{OH}$ High-level output voltage	$V_{CC} = \text{MIN}$ , $V_{IH} = 2 \text{ V}$ , $V_{IL} = V_{IL \text{ max}}$ , $I_{OH} = -400 \mu\text{A}$	2.5	3.4		2.7	3.4		V
$V_{OL}$ Low-level output voltage	$V_{CC} = \text{MIN}$ , $V_{IH} = 2 \text{ V}$ , $V_{IL} = V_{IL \text{ max}}$			0.25	0.4	0.25	0.4	V
						0.35	0.5	
$I_I$ Input current at maximum input voltage	$V_{CC} = \text{MAX}$ , $V_I = 7 \text{ V}$			0.1			0.1	mA
$I_{IH}$ High-level input current	$V_{CC} = \text{MAX}$ , $V_I = 2.7 \text{ V}$			20			20	$\mu$ A
$I_{IL}$ Low-level input current	$V_{CC} = \text{MAX}$ , $V_I = 0.4 \text{ V}$			-0.4			-0.4	mA
$I_{OS}$ Short-circuit output current <sup>§</sup>	$V_{CC} = \text{MAX}$	-20		-100		-20		mA
$I_{CC}$ Supply current	$V_{CC} = \text{MAX}$ , See Note 2		13	21		13	21	mA

<sup>†</sup>For conditions shown as MIN or MAX, use the appropriate value specified under recommended operating conditions.

<sup>‡</sup>All typical values are at  $V_{CC} = 5 \text{ V}$ ,  $T_A = 25^\circ\text{C}$ .

<sup>§</sup>Not more than one output should be shorted at a time, and duration of the short-circuit should not exceed one second.

NOTE 2: With all outputs open and all inputs except clock low,  $I_{CC}$  is measured after applying a momentary 4.5 V, followed by ground, to the clock input.

switching characteristics,  $V_{CC} = 5 \text{ V}$ ,  $T_A = 25^\circ\text{C}$

PARAMETER	TEST CONDITIONS	MIN	TYP	MAX	UNIT
$t_{PLH}$ Propagation delay time, low-to-high-level output	$C_L = 15 \text{ pF}$ , $R_L = 2 \text{ k}\Omega$ ,		18	27	ns
$t_{PHL}$ Propagation delay time, high-to-low-level output	See Note 4		21	32	

NOTE 4: Load circuit and waveforms are shown on page 3-11.

# TYPES SN54298, SN54LS298, SN74298, SN74LS298

## QUADRUPLE 2-INPUT MULTIPLEXERS WITH STORAGE

### TYPICAL APPLICATION DATA

This versatile multiplexer/register can be connected to operate as a shift register that can shift N-places in a single clock pulse.

The following figure illustrates a BCD shift register that will shift an entire 4-bit BCD digit in one clock pulse.

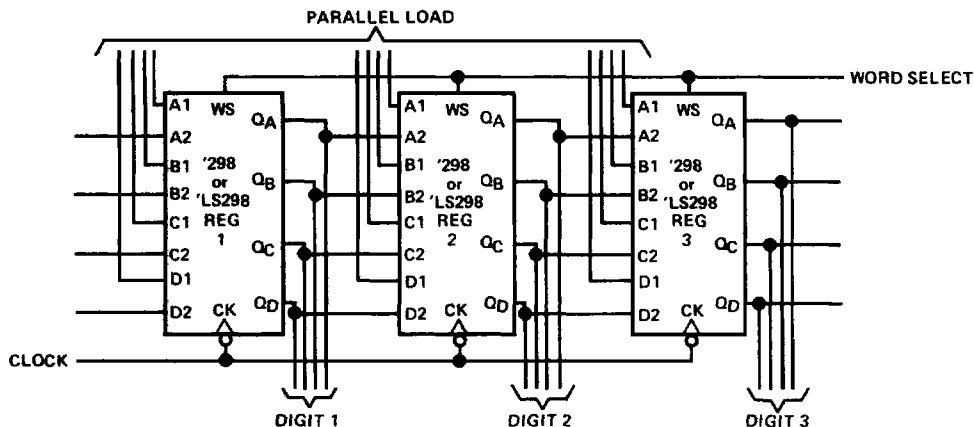

When the word-select input is high and the registers are clocked, the contents of register 1 is transferred (shifted) to register 2 and etc. In effect, the BCD digits are shifted one position. In addition, this application retains a parallel-load capability which means that new BCD data can be entered in the entire register with one clock pulse. This arrangement can be modified to perform the shifting of binary data for any number of bit locations.

Another function that can be implemented with the '298 or 'LS298 is a register that can be designed specifically for supporting multiplier or division operations. The example below is a one place/two-place shift register.

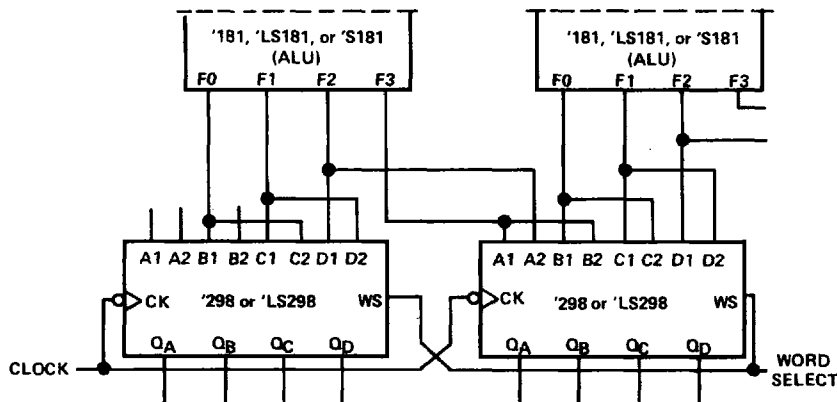

When word select is low and the register is clocked, the outputs of the arithmetic/logic units (ALU's) are shifted one place. When word select is high and the registers are clocked, the data is shifted two places.