

**SPECIFICATION:**

**MATERIAL:**  
 MOULDING = HIGH TEMPERATURE NYLON 6T, UL94V-0, BLACK  
 PINS = BRASS  
**FINISH:**  
 PINS: SEE BOX  
**ELECTRICAL:**  
 CURRENT RATING = 3A MAX  
 CONTACT RESISTANCE = 30 mΩ MAX  
 INSULATION RESISTANCE = 10,000 MΩ MIN  
 DIELECTRIC STRENGTH = 750V AC/DC  
**ENVIRONMENTAL:**  
 TEMPERATURE RANGE = -40°C TO +105°C  
**PACKING:**  
 BAG

**NOTES:**

1. MAXIMUM PERMISSIBLE OUT OF SQUARE OF PIN TO MOULDING TO BE 0.10mm IN ANY DIRECTION.
2. CONTACT LEG VARIATION ON COMPLETE ASSEMBLY NOT TO EXCEED 0.10mm.
3. CO-PLANARITY: DEVIATION FROM FLATNESS OF SMT TAILS MUST NOT EXCEED 0.20mm.
4. ANGULAR DISPLACEMENT OF SMT TAILS MUST NOT EXCEED 1° PER SIDE.

**FINISH**

(TICK APPLICABLE):

- 100% TIN
- GOLD

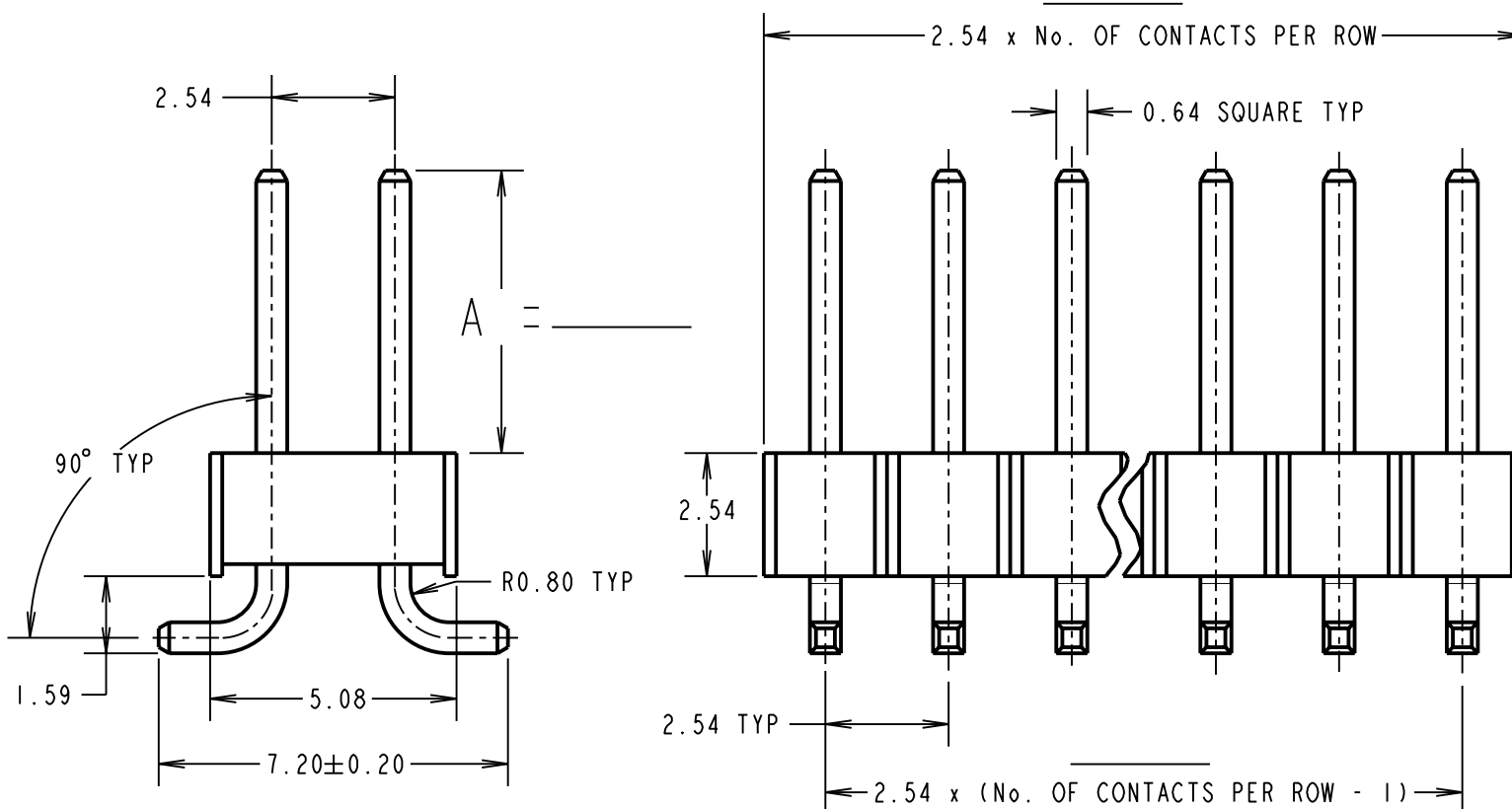

THIS SKETCH IS FOR QUOTATION PURPOSES ONLY

PLEASE NOTE:

B = \_\_\_\_\_

DATE OF SKETCH:

REQUESTED BY:

No. OF CONTACTS PER ROW:

**HARWIN**

THIS DRAWING AND ANY INFORMATION OR DESCRIPTIVE MATTER SET OUT HEREON ARE CONFIDENTIAL AND COPYRIGHT PROPERTY OF THE HARWIN GROUP AND MUST NOT BE DISCLOSED, LOANED, COPIED OR USED FOR MANUFACTURING, TENDERING OR FOR ANY OTHER PURPOSE WITHOUT THEIR WRITTEN PERMISSION.

**TOLERANCES**  
 X. = ±1mm  
 X.X = ±0.25mm  
 X.XX = ±0.10mm  
 X.XXX = ±0.01mm  
 ANGLES = ±5°  
 UNLESS STATED

**TITLE:**  
 2.54mm PITCH DIL VERTICAL SMT TAIL PIN HEADER VARIANT

**DRAWING No.:** M20- \_\_\_\_\_ S \_\_\_\_\_

|   |   |  |
|---|---|--|
| <b>HARWIN INC</b><br>U.S.A.<br>TEL: (812) 542 2540<br>FAX: (812) 542 2541 | <b>HARWIN PLC</b><br>U.K.<br>TEL: 023 9231 4545<br>FAX: 023 9231 4590 | <b>HARWIN PTE</b><br>SINGAPORE<br>TEL: 65 6779 4909<br>FAX: 65 6779 3868 |
|---|---|--|