

CMOS POSITIVE VOLTAGE REGULATORS
VERY LOW DROP - VERY LOW QUIESCENT

- LOW CURRENT CONSUMPTION (TYP. 19 μ A)
- WIDE OPERATING VOLTAGE RANGE
- VERY LOW DROP OUT VOLTAGE
($V_i - V_o < 0.2$ V, $I_o = 40$ mA)
- CMOS TECHNOLOGY

DESCRIPTION

The C78L00 series is a CMOS Positive Voltage Regulators. These regulators contains internal precision voltage reference, error amplifier, control transistor and output voltage setting resistor.

The regulation voltage is fixed by internal circuits and the following lines of different output voltages are available.

This series is suitable for battery operated items and battery back-up systems because of low current consumption and low drop out voltage.

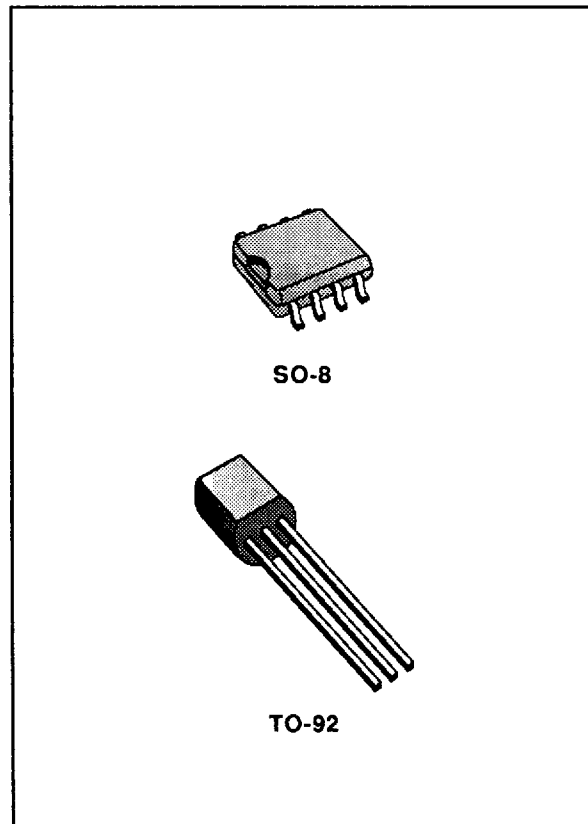

SCHEMATIC DIAGRAM

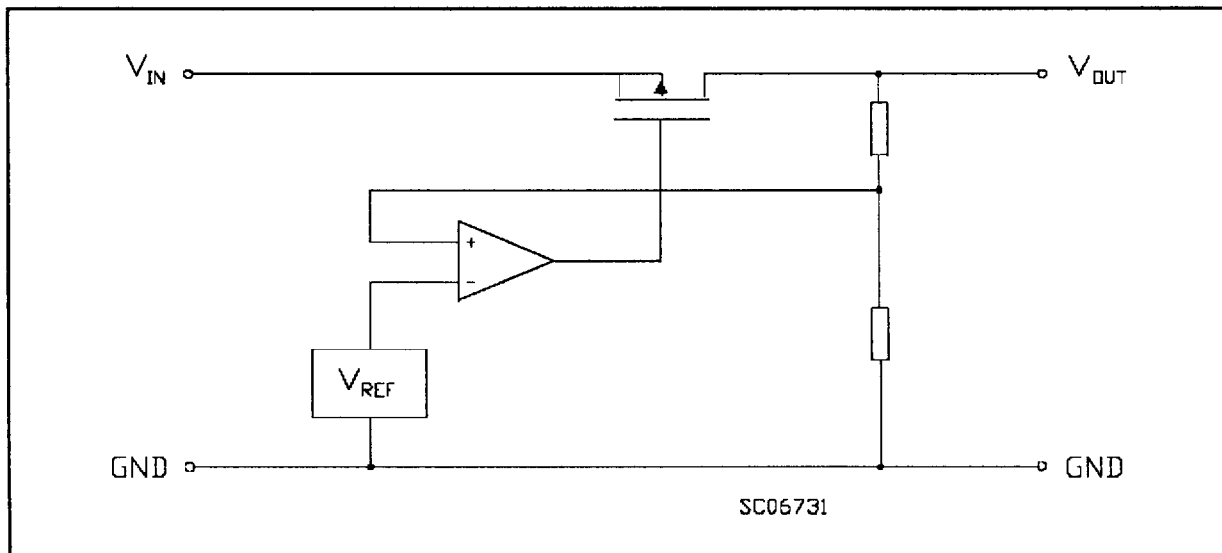

C78L00 SERIES

ABSOLUTE MAXIMUM RATING

Symbol	Parameter	Value	Unit
V_i	DC Input Voltage	14	V
V_o	Maximum Output Voltage	5.5	V
I_o	Output Current	100	mA
P_{tot}	Power Dissipation	Internally limited (*)	
T_{stg}	Storage Temperature Range	- 40 to 150	°C
T_{op}	Operating Junction Temperature Range	For C78L00B For C78L00C	- 40 to 150 0 to 125 °C
T_{sold}	Soldering Temperature	260	°C
t_{sold}	Soldering Time	10	sec

(*) Our SO-8 package used for Voltage Regulators is modified internally to have pins 2, 3, 6 and 7 electrically commoned to the die attach flag. This particular frame decreases the total thermal resistance of the package and increases its ability to dissipate power when an appropriate area of copper on the printed circuit board is available for the heatsinking. The external dimensions are the same as for the standard SO-8

TEST CIRCUITS

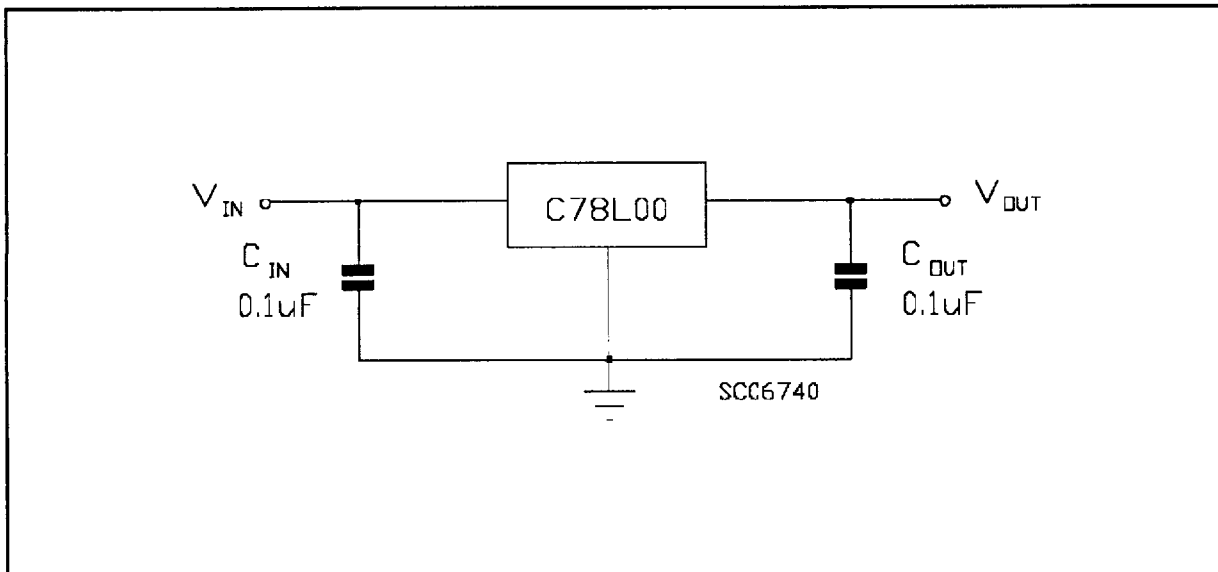

CONNECTION DIAGRAM AND ORDERING NUMBERS (top view)

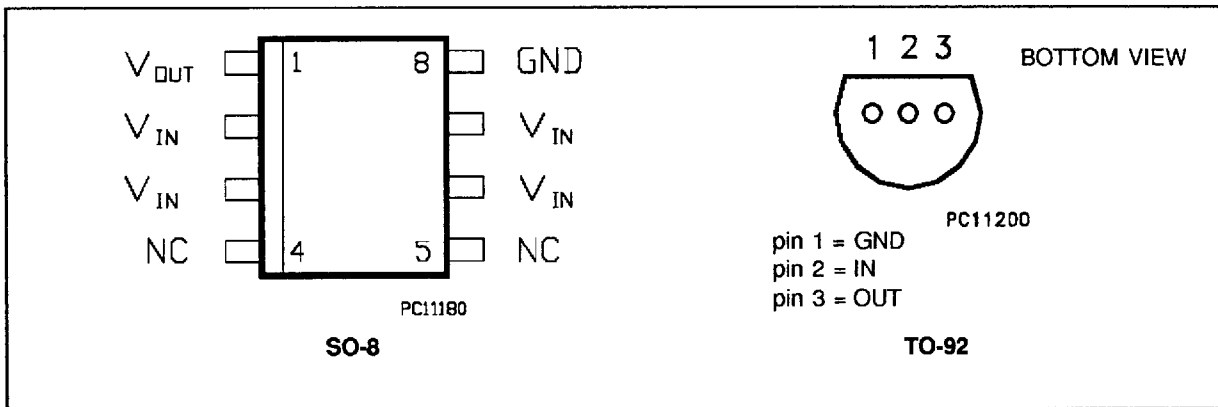

Type	SO-8	TO-92	Output Voltage	Note
C78L03B	C78L03BD	C78L03BZ	3 V	Available
C78L03C	C78L03CD	C78L03CZ	3 V	Available
C78L05B	C78L05BD	C78L05BZ	5 V	Available
C78L05C	C78L05CD	C78L05CZ	5 V	Available
C78L12B	C78L12BD	C78L12BZ	1.2 V	On Request
C78L12C	C78L12CD	C78L12CZ	1.2 V	On Request
C78L15B	C78L15BD	C78L15BZ	1.5 V	On Request
C78L15C	C78L15CD	C78L15CZ	1.5 V	On Request
C78L25B	C78L25BD	C78L25BZ	2.5 V	On Request
C78L25C	C78L25CD	C78L25CZ	2.5 V	On Request
C78L27B	C78L27BD	C78L27BZ	2.7 V	On Request
C78L27C	C78L27CD	C78L27CZ	2.7 V	On Request
C78L32B	C78L32BD	C78L32BZ	3.2 V	On Request
C78L32C	C78L32CD	C78L32CZ	3.2 V	On Request
C78L35B	C78L35BD	C78L35BZ	3.5 V	On Request
C78L35C	C78L35CD	C78L35CZ	3.5 V	On Request
C78L40B	C78L40BD	C78L40BZ	4 V	On Request
C78L40C	C78L40CD	C78L40CZ	4 V	On Request
C78L45B	C78L45BD	C78L45BZ	4.5 V	On Request
C78L45C	C78L45CD	C78L45CZ	4.5 V	On Request
C78L52B	C78L52BD	C78L52BZ	5.2 V	On Request
C78L52C	C78L52CD	C78L52CZ	5.2 V	On Request
C78L55B	C78L55BD	C78L55BZ	5.5 V	On Request
C78L55C	C78L55CD	C78L55CZ	5.5 V	On Request

C78L00 SERIES

ELECTRICAL CHARACTERISTICS FOR C78L12 (refer to the test circuits, $T_a = 25\text{ }^\circ\text{C}$,
 $V_i = 3\text{V}$, $C_i = 0.1\text{ }\mu\text{F}$, $C_o = 0.1\text{ }\mu\text{F}$ unless otherwise specified)

Symbol	Parameter	Test Conditions	Min.	Typ.	Max.	Unit
V_o	Output Voltage	$I_o = 5\text{ mA}$	1.1	1.2	1.3	V
V_i	Input Voltage				12	V
ΔV_o	Line Regulation	$V_i = 1.5\text{ to }12\text{ V}$ $I_o = 5\text{ mA}$		0.1		%/V
ΔV_o	Load Regulation	$I_o = 1\text{ to }15\text{ mA}$		10	180	mV
I_d	Quiescent Current			14	30	μA
eN	Output Noise Voltage	$B = 10\text{Hz to }100\text{KHz}$ $T_j = 25\text{ }^\circ\text{C}$		30		μV
SVR	Supply Voltage Rejection	$I_o = 5\text{ mA}$ $f = 120\text{ Hz}$ $T_j = 25\text{ }^\circ\text{C}$ $V_i = 2.5\text{ to }3.5\text{ V}$		45		dB
V_d	Dropout Voltage	$I_o = 0.5\text{ mA}$		0.02	0.3	V

ELECTRICAL CHARACTERISTICS FOR C78L03 (refer to the test circuits, $T_a = 25\text{ }^\circ\text{C}$,
 $V_i = 5\text{V}$, $C_i = 0.1\text{ }\mu\text{F}$, $C_o = 0.1\text{ }\mu\text{F}$ unless otherwise specified)

Symbol	Parameter	Test Conditions	Min.	Typ.	Max.	Unit
V_o	Output Voltage	$I_o = 10\text{ mA}$	2.85	3	3.15	V
V_i	Input Voltage				12	V
ΔV_o	Line Regulation	$V_i = 4\text{ to }12\text{ V}$ $I_o = 5\text{ mA}$		0.1		%/V
ΔV_o	Load Regulation	$I_o = 1\text{ to }20\text{ mA}$		15	180	mV
I_d	Quiescent Current			16	30	μA
eN	Output Noise Voltage	$B = 10\text{Hz to }100\text{KHz}$ $T_j = 25\text{ }^\circ\text{C}$		35		μV
SVR	Supply Voltage Rejection	$I_o = 5\text{ mA}$ $f = 120\text{ Hz}$ $T_j = 25\text{ }^\circ\text{C}$ $V_i = 4.5\text{ to }5.5\text{ V}$		43		dB
V_d	Dropout Voltage	$I_o = 20\text{ mA}$		0.2	0.6	V

ELECTRICAL CHARACTERISTICS FOR C78L05 (refer to the test circuits, $T_a = 25\text{ }^\circ\text{C}$,
 $V_i = 7\text{V}$, $C_i = 0.1\text{ }\mu\text{F}$, $C_o = 0.1\text{ }\mu\text{F}$ unless otherwise specified)

Symbol	Parameter	Test Conditions	Min.	Typ.	Max.	Unit
V_o	Output Voltage	$I_o = 30\text{ mA}$	4.75	5	5.25	V
V_i	Input Voltage				12	V
ΔV_o	Line Regulation	$V_i = 6\text{ to }12\text{ V}$ $I_o = 5\text{ mA}$		0.1		%/V
ΔV_o	Load Regulation	$I_o = 1\text{ to }40\text{ mA}$		35	120	mV
I_d	Quiescent Current			19	30	μA
eN	Output Noise Voltage	$B = 10\text{Hz to }100\text{KHz}$ $T_j = 25\text{ }^\circ\text{C}$		50		μV
SVR	Supply Voltage Rejection	$I_o = 5\text{ mA}$ $f = 120\text{ Hz}$ $T_j = 25\text{ }^\circ\text{C}$ $V_i = 6.5\text{ to }7.5\text{ V}$		40		dB
V_d	Dropout Voltage	$I_o = 40\text{ mA}$		0.3	0.6	V

Figure 1: Output Voltage vs Input Voltage

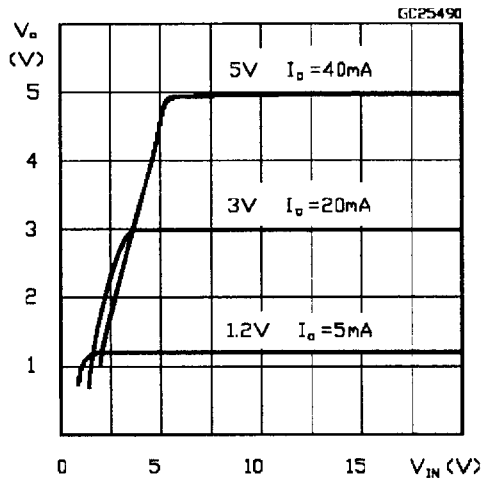

Figure 2: Output Voltage vs Output Current

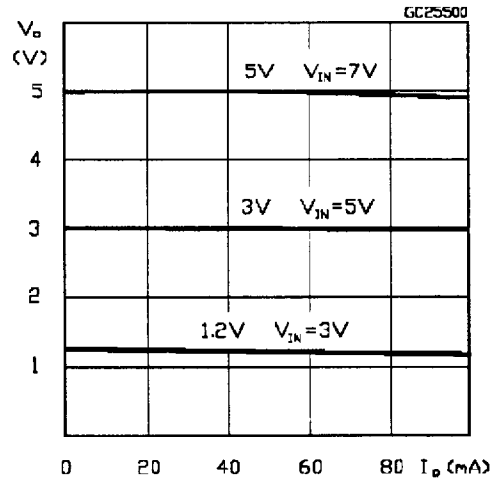

Figure 3: Quiescent Current

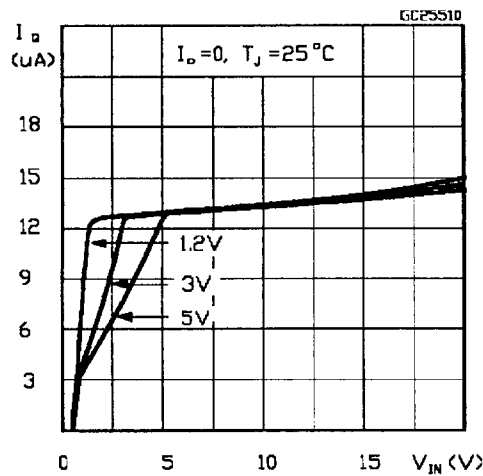

Figure 4: Dropout Voltage

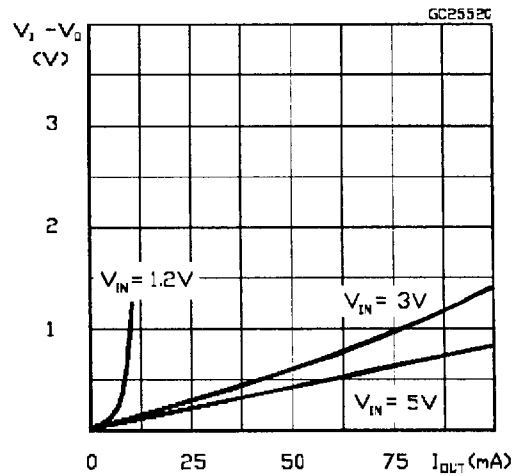

Figure 5: Quiescent Current

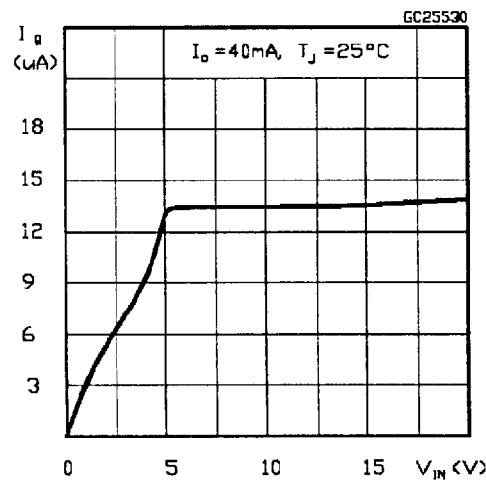
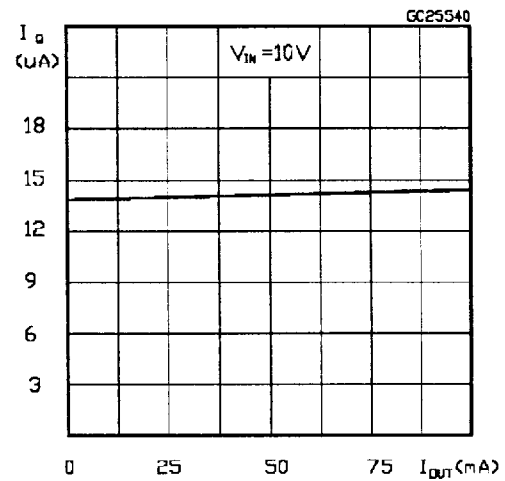
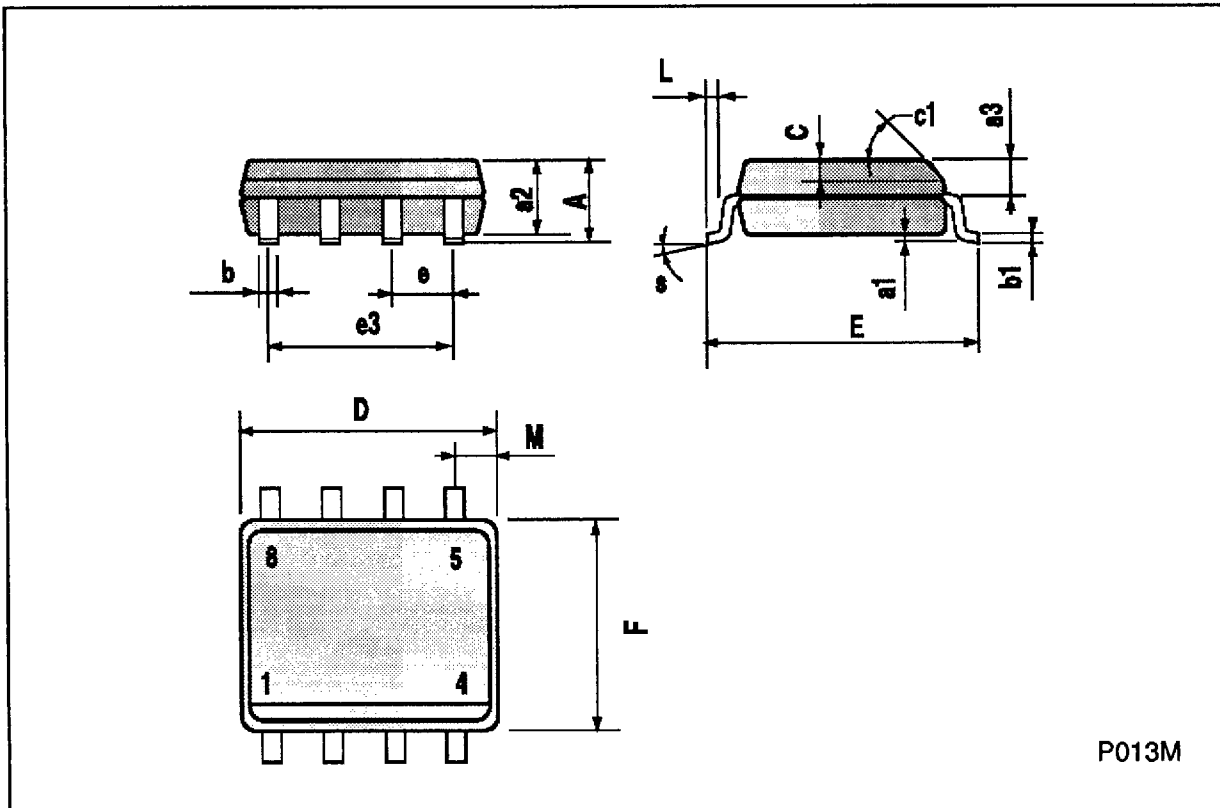

Figure 6: Quiescent Current



SO8 MECHANICAL DATA

DIM.	mm			inch		
	MIN.	TYP.	MAX.	MIN.	TYP.	MAX.
A			1.75			0.068
a1	0.1		0.25	0.003		0.009
a2			1.65			0.064
a3	0.65		0.85	0.025		0.033
b	0.35		0.48	0.013		0.018
b1	0.19		0.25	0.007		0.010
C	0.25		0.5	0.010		0.019
c1	45° (typ.)					
D	4.8		5.0	0.188		0.196
E	5.8		6.2	0.228		0.244
e		1.27			0.050	
e3		3.81			0.150	
F	3.8		4.0	0.14		0.157
L	0.4		1.27	0.015		0.050
M			0.6			0.023
S	8° (max.)					



P013M

TO-92 MECHANICAL DATA

DIM.	mm			inch		
	MIN.	TYP.	MAX.	MIN.	TYP.	MAX.
A	4.58		5.33	0.180		0.210
B	4.45		5.2	0.175		0.204
C	3.2		4.2	0.126		0.165
D	12.7			0.500		
E		1.27			0.050	
F	0.4		0.51	0.016		0.020
G	0.35			0.14		

