

SN54LS242, SN54LS243, SN74LS242, SN74LS243 QUADRUPLE BUS TRANSCEIVERS

SDLS145 – APRIL 1985 – REVISED MARCH 1988

- Two-Way Asynchronous Communication Between Data Buses
- PNP Inputs Reduce D-C Loading
- Hysteresis (Typically 400 mV) at Inputs Improves Noise Margin

description

These four-data-line transceivers are designed for asynchronous two-way communications between data buses. The SN74LS' can be used to drive terminated lines down to 133 ohms.

The SN54' family is characterized for operation over the full military temperature range of -55°C to 125°C . The SN74' family is characterized for operation from 0°C to 70°C .

FUNCTION TABLE (EACH TRANSCEIVER)

INPUTS		'LS242	'LS243
$\bar{G}AB$	GBA		
L	L	\bar{A} to B	A to B
H	H	\bar{B} to A	B to A
H	L	Isolation	Isolation
L	H	Latch A and B ($A = \bar{B}$)	Latch A and B ($A = B$)

SN54LS242, SN54LS243 . . . J OR W PACKAGE
SN74LS242, SN74LS243 . . . D OR N PACKAGE
(TOP VIEW)

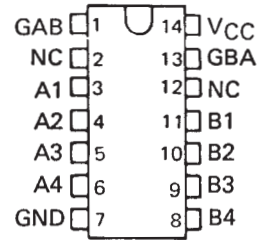

SN54LS242, SN54LS243 . . . FK PACKAGE
(TOP VIEW)

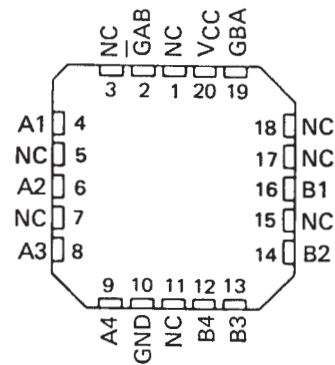

NC—No internal connection

schematics of inputs and outputs

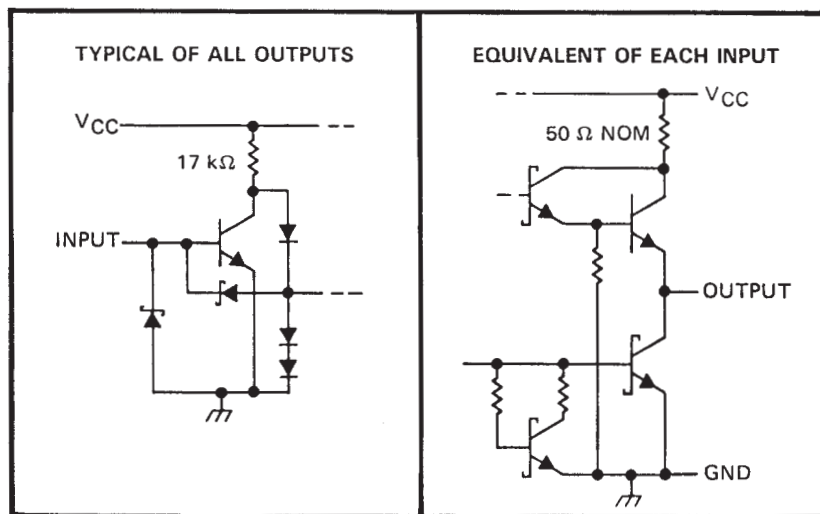

PRODUCTION DATA information is current as of publication date. Products conform to specifications per the terms of Texas Instruments standard warranty. Production processing does not necessarily include testing of all parameters.

**TEXAS
INSTRUMENTS**

POST OFFICE BOX 655303 • DALLAS, TEXAS 75265

Copyright © 1988, Texas Instruments Incorporated

SN54LS242, SN54LS243, SN74LS242, SN74LS243 QUADRUPLE BUS TRANSCEIVERS

SDLS145 – APRIL 1985 – REVISED MARCH 1988

logic symbols†

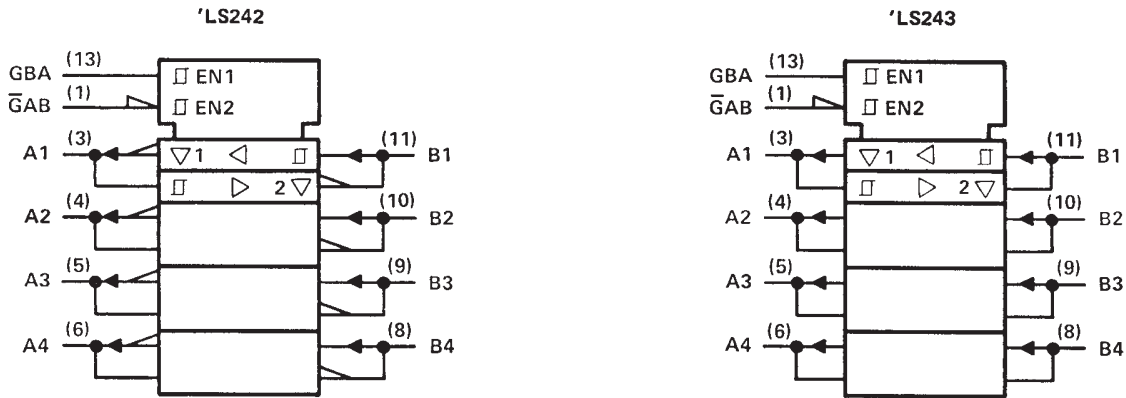

†These symbols are in accordance with ANSI/IEEE Std. 91-1984 and IEC Publication 617-12.

logic diagrams (positive logic)

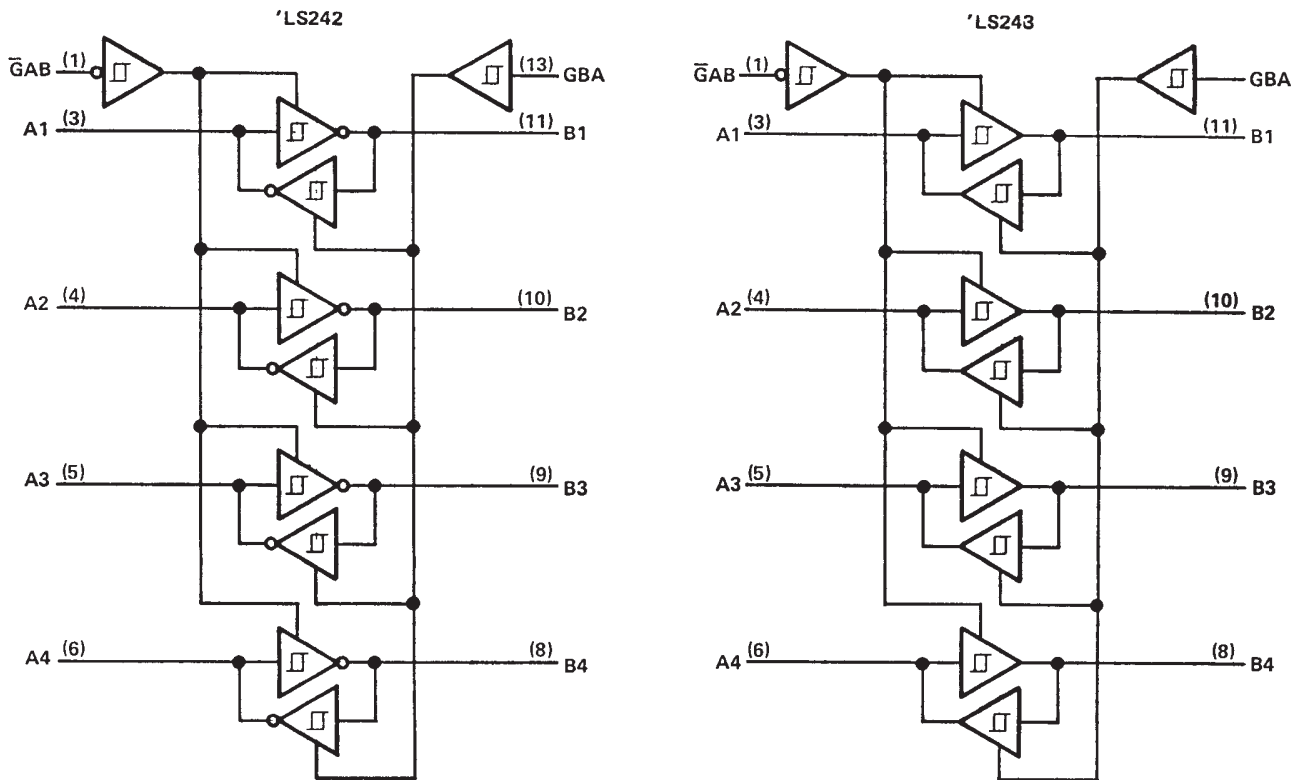

Pin numbers shown are for D, J, N, and W packages.

absolute maximum ratings over operating free-air temperature range (unless otherwise noted)

Supply voltage, V_{CC} (see Note 1)	7 V
Input voltage	7 V
Off-state output voltage	5.5 V
Operating free-air temperature range: SN54LS'	-55°C to 125°C
SN74LS'	0°C to 70°C
Storage temperature range	-65°C to 150°C

NOTE 1: Voltage values are with respect to network ground terminal.



POST OFFICE BOX 655303 • DALLAS, TEXAS 75265

SN54LS242, SN54LS243, SN74LS242, SN74LS243 QUADRUPLE BUS TRANSCEIVERS

SDLS145 – APRIL 1985 – REVISED MARCH 1988

recommended operating conditions

		SN54LS'			SN74LS'			UNIT		
		MIN	NOM	MAX	MIN	NOM	MAX			
V_{CC}	Supply voltage, (see Note 1)	4.5	5	5.5	4.75	5	5.25	V		
V_{IH}	High-level input voltage	2			2			V		
V_{IL}	Low-level input voltage	0.7			0.8			V		
I_{OH}	High-level output current	-12			-15			mA		
I_{OL}	Low-level output current	12			24			mA		
T_A	Operating free-air temperature	-55			125			0	70	°C

electrical characteristics over recommended operating free-air temperature range (unless otherwise noted)

PARAMETER	TEST CONDITIONS†	SN54LS'			SN74LS'			UNIT	
		MIN	TYP‡	MAX	MIN	TYP‡	MAX		
V_{IK}	A or B	$V_{CC} = \text{MIN}, I_I = -18 \text{ mA}$			-1.5			V	
Hysteresis ($V_{T+} - V_{T-}$)		$V_{CC} = \text{MIN}$			0.2	0.4	0.2	0.4	V
V_{OH}		$V_{CC} = \text{MIN}, V_{IH} = 2 \text{ V}, V_{IL} = \text{MAX}, I_{OH} = -3 \text{ mA}$			2.4	3.1	2.4	3.1	V
		$V_{CC} = \text{MIN}, V_{IH} = 2 \text{ V}, V_{IL} = 0.5 \text{ V}, I_{OH} = \text{MAX}$			2		2		
V_{OL}		$V_{CC} = \text{MIN}, V_{IH} = 2 \text{ V}, V_{IL} = \text{MAX}$			0.25		0.4		V
I_{OZH}		$V_{CC} = \text{MAX}, V_{IH} = 2 \text{ V}, V_{IL} = \text{MAX}$			40			40	μA
I_{OZL}		$V_{CC} = \text{MAX}, V_{IH} = 2 \text{ V}, V_{IL} = \text{MAX}$			-200			-200	μA
I_I	A or B	$V_{CC} = \text{MAX}, V_I = 5.5 \text{ V}$			0.1			0.1	mA
	$\overline{\text{GAB}}$ or GBA	$V_{CC} = \text{MAX}, V_I = 7 \text{ V}$			0.1			0.1	
I_{IH}		$V_{CC} = \text{MAX}, V_I = 2.7 \text{ V}$			20			20	μA
I_{IL}	A inputs	$V_{CC} = \text{MAX}, V_I = 0.4 \text{ V}, \overline{\text{GAB}}$ and GBA at 0 V			-0.2			-0.2	mA
	B inputs	$V_{CC} = \text{MAX}, V_I = 0.4 \text{ V}, \overline{\text{GAB}}$ and GBA at 4.5 V			-0.2			-0.2	
	$\overline{\text{GAB}}$ or GBA	$V_{CC} = \text{MAX}, V_I = 0.4 \text{ V}$			-0.2			-0.2	
$I_{OS}§$		$V_{CC} = \text{MAX}$			-40	-225	-40	-225	mA
I_{CC}	Outputs high	$V_{CC} = \text{MAX}, I_{OH} = -12 \text{ mA}, I_{OL} = 24 \text{ mA}$			22		38		mA
	Outputs low	$V_{CC} = \text{MAX}, I_{OH} = -12 \text{ mA}, I_{OL} = 24 \text{ mA}$			29		50		
	All outputs disabled	See Note 2			29		50		
					32		54		

† For conditions shown as MIN or MAX, use the appropriate value specified under recommended operating conditions.

‡ All typical values are at $V_{CC} = 5 \text{ V}, T_A = 25^\circ \text{C}$.

§ Not more than one output should be shorted at a time, and duration of the short-circuit should not exceed one second.

NOTE 2: I_{CC} is measured with transceivers enabled in one direction only, or with all transceivers disabled.

switching characteristics, $V_{CC} = 5 \text{ V}, T_A = 25^\circ \text{C}$

PARAMETER	TEST CONDITIONS	'LS242			'LS243			UNIT	
		MIN	TYP	MAX	MIN	TYP	MAX		
t_{PLH}	$R_L = 667 \Omega$ See Note 3				9	14	12	18	ns
t_{PHL}					12	18	12	18	ns
t_{PZL}					20	30	20	30	ns
t_{PZH}					15	23	15	23	ns
t_{PLZ}	$R_L = 667 \Omega$, See Note 3				10	20	10	20	ns
t_{PHZ}					15	25	15	25	ns

NOTE 3: Load circuits and voltage waveforms are shown in Section 1.



IMPORTANT NOTICE

Texas Instruments and its subsidiaries (TI) reserve the right to make changes to their products or to discontinue any product or service without notice, and advise customers to obtain the latest version of relevant information to verify, before placing orders, that information being relied on is current and complete. All products are sold subject to the terms and conditions of sale supplied at the time of order acknowledgement, including those pertaining to warranty, patent infringement, and limitation of liability.

TI warrants performance of its semiconductor products to the specifications applicable at the time of sale in accordance with TI's standard warranty. Testing and other quality control techniques are utilized to the extent TI deems necessary to support this warranty. Specific testing of all parameters of each device is not necessarily performed, except those mandated by government requirements.

CERTAIN APPLICATIONS USING SEMICONDUCTOR PRODUCTS MAY INVOLVE POTENTIAL RISKS OF DEATH, PERSONAL INJURY, OR SEVERE PROPERTY OR ENVIRONMENTAL DAMAGE ("CRITICAL APPLICATIONS"). TI SEMICONDUCTOR PRODUCTS ARE NOT DESIGNED, AUTHORIZED, OR WARRANTED TO BE SUITABLE FOR USE IN LIFE-SUPPORT DEVICES OR SYSTEMS OR OTHER CRITICAL APPLICATIONS. INCLUSION OF TI PRODUCTS IN SUCH APPLICATIONS IS UNDERSTOOD TO BE FULLY AT THE CUSTOMER'S RISK.

In order to minimize risks associated with the customer's applications, adequate design and operating safeguards must be provided by the customer to minimize inherent or procedural hazards.

TI assumes no liability for applications assistance or customer product design. TI does not warrant or represent that any license, either express or implied, is granted under any patent right, copyright, mask work right, or other intellectual property right of TI covering or relating to any combination, machine, or process in which such semiconductor products or services might be or are used. TI's publication of information regarding any third party's products or services does not constitute TI's approval, warranty or endorsement thereof.

PRODUCT FOLDER | PRODUCT INFO: [FEATURES](#) | [DESCRIPTION](#) | [DATASHEETS](#) | [PRICING/AVAILABILITY/PKG](#) | [APPLICATION NOTES](#) | [USER GUIDES](#) | [MORE LITERATURE](#)

PRODUCT SUPPORT: [TRAINING](#)

SN54LS243, Quadruple Bus Transceivers

DEVICE STATUS: **ACTIVE**

PARAMETER NAME	SN54LS243	SN74LS243
Voltage Nodes (V)	5	5
Vcc range (V)	4.5 to 5.5	4.75 to 5.25
Input Level	TTL	TTL
Output Level	TTL	TTL
Output Drive (mA)		-15/24
No. of Outputs	4	4
Logic	True	True
Static Current		44
tpd max (ns)		18

FEATURES

[▲ Back to Top](#)

- Two-Way Asynchronous Communication Between Data Buses
- PNP Inputs Reduce D-C Loading
- Hysteresis (Typically 400 mV) at Inputs Improves Noise Margin

DESCRIPTION

[▲ Back to Top](#)

These four-data-line transceivers are designed for asynchronous two-way communications between data buses. The SN74LS' can be used to drive terminated lines down to 133 ohms.

The SN54' family is characterized for operation over the full military temperature range of -55°C to 125°C. The SN74' family is characterized for operation from 0°C to 70°C.

TECHNICAL DOCUMENTS

[▲ Back to Top](#)

To view the following documents, [Acrobat Reader 4.0](#) is required.

To download a document to your hard drive, right-click on the link and choose 'Save'.

DATASHEET

[▲ Back to Top](#)

Full datasheet in Acrobat PDF: [sn54ls243.pdf](#) (135 KB) (Updated: 03/01/1988)

APPLICATION NOTES

[▲ Back to Top](#)

View Application Notes for [Digital Logic](#)

- [Designing With Logic \(Rev. C\)](#) (SDYA009C - Updated: 06/01/1997)
- [Designing with the SN54/74LS123 \(Rev. A\)](#) (SDLA006A - Updated: 03/01/1997)
- [Evaluation of Nickel/Palladium/Gold-Finished Surface-Mount Integrated Circuits](#) (SZZA026 - Updated: 06/20/2001)

- [Input and Output Characteristics of Digital Integrated Circuits](#) (SDYA010 - Updated: 10/01/1996)
- [LVT-to-LVTH Conversion](#) (SCEA010 - Updated: 12/08/1998)
- [Live Insertion](#) (SDYA012 - Updated: 10/01/1996)
- [Logic Solutions For IEEE Std 1284](#) (SCEA013 - Updated: 06/01/1999)
- [TI IBIS File Creation, Validation, and Distribution Processes](#) (SZZA034 - Updated: 08/29/2002)
- [Understanding and Interpreting Texas Instruments Standard-Logic Products Data Sh \(Rev. A\)](#) (SZZA036A - Updated: 02/27/2003)

MORE LITERATURE

[▲Back to Top](#)

- [Enhanced Plastic Portfolio Brochure](#) (SGZB004, 387 KB - Updated: 08/19/2002)
- [Logic Reference Guide](#) (SCYB004, 1032 KB - Updated: 10/23/2001)
- [MicroStar Junior BGA Design Summary](#) (SCET004, 167 KB - Updated: 07/28/2000)
- [Military Brief](#) (SGYN138, 803 KB - Updated: 10/10/2000)
- [Overview of IEEE Std 91-1984, Explanation of Logic Symbols Training Booklet \(Rev. A\)](#) (SDYZ001A, 138 KB - Updated: 07/01/1996)
- [Palladium Lead Finish User's Manual](#) (SDYV001, 2041 KB - Updated: 11/01/1996)
- [QML Class V Space Products Military Brief \(Rev. A\)](#) (SGZN001A, 257 KB - Updated: 10/07/2002)

USER GUIDES

[▲Back to Top](#)

- [LOGIC Pocket Data Book](#) (SCYD013, 4837 KB - Updated: 12/05/2002)

PRICING/AVAILABILITY/PKG

[▲Back to Top](#)

DEVICE INFORMATION Updated Daily								TI INVENTORY STATUS As Of 09:00 AM GMT, 17 Apr 2003			REPORTED DISTRIBUTOR INVENTORY As Of 09:00 AM GMT, 17 Apr 2003		
ORDERABLE DEVICE	STATUS	PACKAGE TYPE PINS	TEMP (°C)	DSCC NUMBER	PRODUCT CONTENT	BUDGETARY PRICING QTY SUS	STD PACK QTY	IN STOCK	IN PROGRESS QTY DATE	LEAD TIME	DISTRIBUTOR COMPANY REGION	IN STOCK	PURCHASE
80020022A	OBSOLETE	20	-55 TO 125		View Contents	1KU		0*		Call**	None Reported View Distributors		
8002002CA	ACTIVE	CDIP (J) 14	-55 TO 125		View Contents	1KU 2.59	1	363*	>10k 20 May	6 WKS	Avnet Americas	23	BUY NOW
8002002DA	ACTIVE	CFP (W) 14	-55 TO 125		View Contents	1KU 7.51	1	24*	>10k 20 May	6 WKS	None Reported View Distributors		
SN54LS243J	ACTIVE	CDIP (J) 14	-55 TO 125		View Contents	1KU 2.20	1	96*	>10k 20 May	6 WKS	EBV Electronik Europe	50	BUY NOW
											Rochester Electronics Americas	17	BUY NOW
											Avnet Americas	8	BUY NOW
SNJ54LS243FK	OBSOLETE	20	-55 TO 125		View Contents	1KU		0*		Call**	None Reported View Distributors		
SNJ54LS243J	ACTIVE	CDIP (J) 14	-55 TO 125	8002002CA	View Contents	1KU 2.59	1	0*	>10k 20 May	6 WKS	None Reported View Distributors		
SNJ54LS243W	ACTIVE	CFP (W) 14	-55 TO 125	8002002DA	View Contents	1KU 7.51	1	57*	>10k 20 May	6 WKS	None Reported View Distributors		

[Products](#) | [Applications](#) | [Support](#) | [my.TI](#)

 **TEXAS INSTRUMENTS** © Copyright 1995-2002 Texas Instruments Incorporated. All rights reserved.
[Trademarks](#) | [Privacy Policy](#) | [Terms of Use](#)