

SN54ABT241A, SN74ABT241A OCTAL BUFFERS/DRIVERS WITH 3-STATE OUTPUTS

SCBS184B - JANUARY 1991 - MARCH 1996

- State-of-the-Art EPIC-II[™] BICMOS Design Significantly Reduces Power Dissipation
- Latch-Up Performance Exceeds 500 mA Per JEDEC Standard JESD-17
- ESD Protection Exceeds 2000 V Per MIL-STD-883C, Method 3015; Exceeds 200 V Using Machine Model (C = 200 pF, R = 0)
- Typical V_{OLP} (Output Ground Bounce) < 1 V at V_{CC} = 5 V, T_A = 25°C
- High-Drive Outputs (-32-mA I_{OH}, 64-mA I_{OL})
- Package Options Include Plastic Small-Outline (DW) and Shrink Small-Outline (DB) Packages, Ceramic Chip Carriers (FK), and Plastic (N) and Ceramic (J) DIPs, and Ceramic Flat (W) Packages

SN54ABT241A . . . J OR W PACKAGE
SN74ABT241A . . . DB, DW, OR N PACKAGE
(TOP VIEW)

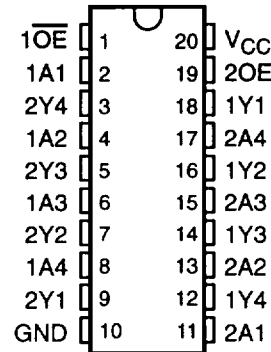

SN54ABT241A . . . FK PACKAGE
(TOP VIEW)

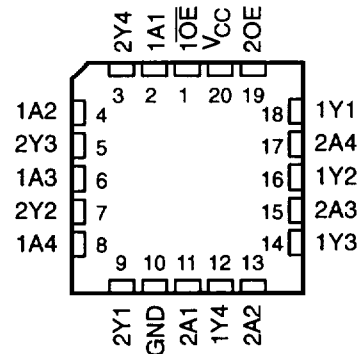

description

These octal buffers and line drivers are designed specifically to improve both the performance and density of 3-state memory address drivers, clock drivers, and bus-oriented receivers and transmitters. Taken together with the 'ABT240A and 'ABT244A, these devices provide the choice of selected combinations of inverting and noninverting outputs, symmetrical active-low output-enable (\overline{OE}) inputs, and complementary OE and \overline{OE} inputs.

To ensure the high-impedance state during power up or power down, \overline{OE} should be tied to V_{CC} through a pullup resistor; the minimum value of the resistor is determined by the current-sinking capability of the driver. OE should be tied to GND through a pulldown resistor; the minimum value of the resistor is determined by the current-sourcing capability of the driver.

The SN74ABT241A is available in TI's shrink small-outline package (DB), which provides the same I/O pin count and functionality of standard small-outline packages in less than half the printed-circuit-board area.

The SN54ABT241A is characterized for operation over the full military temperature range of -55°C to 125°C. The SN74ABT241A is characterized for operation from -40°C to 85°C.



Please be aware that an important notice concerning availability, standard warranty, and use in critical applications of Texas Instruments semiconductor products and disclaimers thereto appears at the end of this data sheet.

EPIC-II[™] is a trademark of Texas Instruments Incorporated.

PRODUCTION DATA information is current as of publication date. Products conform to specifications per the terms of Texas Instruments standard warranty. Production processing does not necessarily include testing of all parameters.

**TEXAS
INSTRUMENTS**

POST OFFICE BOX 655303 • DALLAS, TEXAS 75265

Copyright © 1996, Texas Instruments Incorporated

SN54ABT241A, SN74ABT241A
OCTAL BUFFERS/DRIVERS
WITH 3-STATE OUTPUTS

SCBS184B - JANUARY 1991 - MARCH 1996

FUNCTION TABLES

INPUTS		OUTPUT
$\overline{1OE}$	1A	1Y
L	H	H
L	L	L
H	X	Z

INPUTS		OUTPUT
2OE	2A	2Y
H	H	H
H	L	L
L	X	Z

logic symbol†

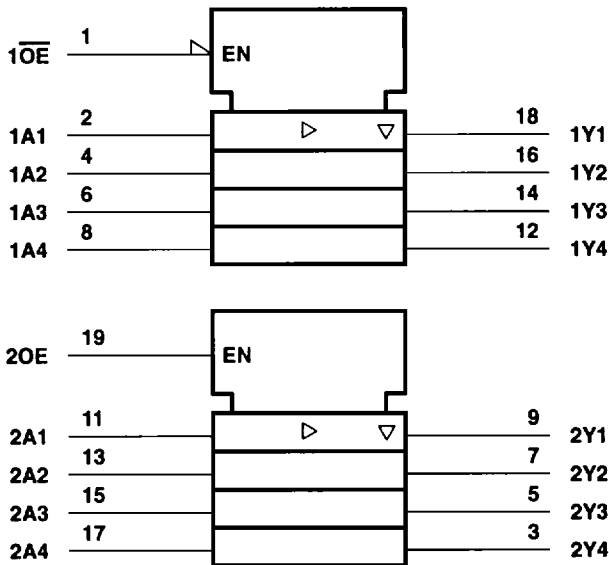

† This symbol is in accordance with ANSI/IEEE Std 91-1984 and IEC Publication 617-12.

logic diagram (positive logic)

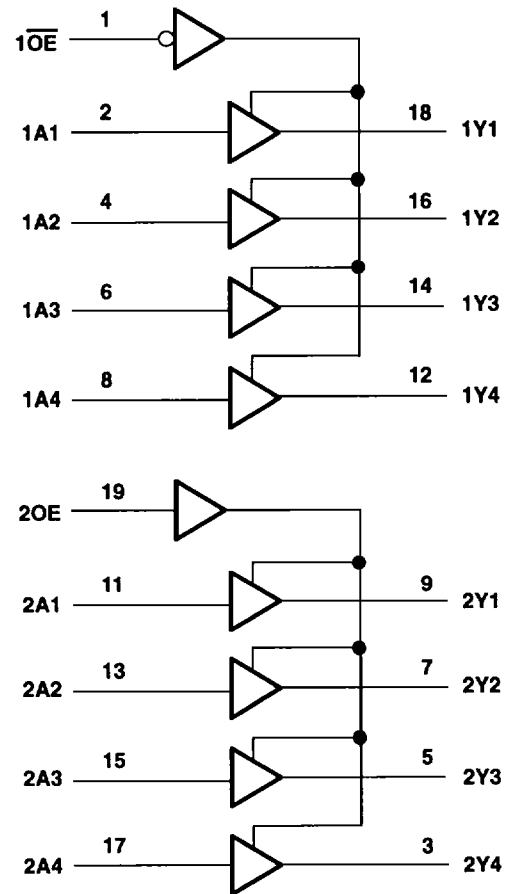

SN54ABT241A, SN74ABT241A
OCTAL BUFFERS/DRIVERS
WITH 3-STATE OUTPUTS

SCBS184B - JANUARY 1991 - MARCH 1996

absolute maximum ratings over operating free-air temperature range (unless otherwise noted)†

Supply voltage range, V_{CC}	-0.5 V to 7 V
Input voltage range, V_I (see Note 1)	-0.5 V to 7 V
Voltage range applied to any output in the high state or power-off state, V_O	-0.5 V to 5.5 V
Current into any output in the low state, I_O : SN54ABT241A	96 mA
SN74ABT241A	128 mA
Input clamp current, I_{IK} ($V_I < 0$)	-18 mA
Output clamp current, I_{OK} ($V_O < 0$)	-50 mA
Maximum power dissipation at $T_A = 55^\circ\text{C}$ (in still air) (see Note 2): DB package	0.6 W
DW package	1.6 W
N package	1.3 W
Storage temperature range, T_{stg}	-65°C to 150°C

† Stresses beyond those listed under "absolute maximum ratings" may cause permanent damage to the device. These are stress ratings only, and functional operation of the device at these or any other conditions beyond those indicated under "recommended operating conditions" is not implied. Exposure to absolute-maximum-rated conditions for extended periods may affect device reliability.

- NOTES: 1. The input and output negative-voltage ratings may be exceeded if the input and output clamp-current ratings are observed.
2. The maximum package power dissipation is calculated using a junction temperature of 150°C and a board trace length of 750 mils, except for the N package, which has a trace length of zero. For more information, refer to the *Package Thermal Considerations* application note in the 1994 *ABT Advanced BiCMOS Technology Data Book*, literature number SCBD002B.

recommended operating conditions (see Note 3)

		SN54ABT241A		SN74ABT241A		UNIT
		MIN	MAX	MIN	MAX	
V_{CC}	Supply voltage	4.5	5.5	4.5	5.5	V
V_{IH}	High-level input voltage	2		2		V
V_{IL}	Low-level input voltage		0.8		0.8	V
V_I	Input voltage	0	V_{CC}	0	V_{CC}	V
I_{OH}	High-level output current		-24		-32	mA
I_{OL}	Low-level output current		48		64	mA
$\Delta t/\Delta v$	Input transition rise or fall rate	Outputs enabled		5	5	ns/V
T_A	Operating free-air temperature	-55	125	-40	85	°C

NOTE 3: Unused or floating inputs must be held high or low.



SN54ABT241A, SN74ABT241A
OCTAL BUFFERS/DRIVERS
WITH 3-STATE OUTPUTS
 SCBS184B – JANUARY 1991 – MARCH 1996

electrical characteristics over recommended operating free-air temperature range (unless otherwise noted)

PARAMETER	TEST CONDITIONS	T _A = 25°C			SN54ABT241A		SN74ABT241A		UNIT
		MIN	TYP†	MAX	MIN	MAX	MIN	MAX	
V _{IK}	V _{CC} = 4.5 V, I _I = -18 mA			-1.2		-1.2		-1.2	V
V _{OH}	V _{CC} = 4.5 V, I _{OH} = -3 mA	2.5			2.5		2.5		V
	V _{CC} = 5 V, I _{OH} = -3 mA	3			3		3		
	V _{CC} = 4.5 V	I _{OH} = -24 mA	2			2			
		I _{OH} = -32 mA	2*					2	
V _{OL}	V _{CC} = 4.5 V	I _{OL} = 48 mA		0.55		0.55			V
		I _{OL} = 64 mA		0.55*			0.55		
I _I	V _{CC} = 5.5 V, V _I = V _{CC} or GND			±1		±1		±1	μA
I _{OZH}	V _{CC} = 5.5 V, V _O = 2.7 V			10		10		10	μA
I _{OZL}	V _{CC} = 5.5 V, V _O = 0.5 V			-10		-10		-10	μA
I _{off}	V _{CC} = 0, V _I or V _O ≤ 4.5 V			±100				±100	μA
I _{CEX}	V _{CC} = 5.5 V, V _O = 5.5 V	Outputs high		50		50		50	μA
I _{O‡}	V _{CC} = 5.5 V, V _O = 2.5 V	-50	-100	-180	-50	-180	-50	-180	mA
I _{CC}	V _{CC} = 5.5 V, V _I = V _{CC} or GND, I _O = 0,	Outputs high		1	250	250	250	250	μA
		Outputs low		24	30	30	30	30	mA
		Outputs disabled		0.5	250	250	250	250	μA
ΔI _{CC} §	V _{CC} = 5.5 V, One input at 3.4 V, Other inputs at V _{CC} or GND	Data inputs	Outputs enabled		1.5	1.5	1.5	1.5	mA
			Outputs disabled		0.05	0.05	0.05	0.05	
		Control inputs		1.5	1.5	1.5	1.5		
C _I	V _I = 2.5 V or 0.5 V		4						pF
C _O	V _O = 2.5 V or 0.5 V		5.5						pF

* On products compliant to MIL-PRF-38535, this parameter does not apply.

† All typical values are at V_{CC} = 5 V.

‡ Not more than one output should be tested at a time, and the duration of the test should not exceed one second.

§ This is the increase in supply current for each input that is at the specified TTL voltage level rather than V_{CC} or GND.



SN54ABT241A, SN74ABT241A
OCTAL BUFFERS/DRIVERS
WITH 3-STATE OUTPUTS

SCBS184B – JANUARY 1991 – MARCH 1996

switching characteristics over recommended ranges of supply voltage and operating free-air temperature, $C_L = 50$ pF (unless otherwise noted) (see Figure 1)

PARAMETER	FROM (INPUT)	TO (OUTPUT)	$V_{CC} = 5$ V, $T_A = 25^\circ$ C			SN54ABT241A		UNIT
			MIN	TYP	MAX	MIN	MAX	
tPLH	A	Y	1	2.6	4.1	0.8	5.3	ns
tPHL			1	2.9	4.2	0.8	5	
tPZH	\overline{OE} or OE	Y	1.1	4.8	6.3	1	7	ns
tPZL			1.3	4.3	5.8	1	7	
tPHZ	\overline{OE} or OE	Y	1.1	4.6	6.1	0.8	7.9	ns
tPLZ			1	3.9	5.4	0.8	6.2	

switching characteristics over recommended ranges of supply voltage and operating free-air temperature, $C_L = 50$ pF (unless otherwise noted) (see Figure 1)

PARAMETER	FROM (INPUT)	TO (OUTPUT)	$V_{CC} = 5$ V, $T_A = 25^\circ$ C			SN74ABT241A		UNIT
			MIN	TYP	MAX	MIN	MAX	
tPLH	A	Y	1	2.6	4.1	1	4.6	ns
tPHL			1	2.9	4.4	1	4.6	
tPZH	\overline{OE} or OE	Y	1.1	4.8	6.3	1.1	6.8	ns
tPZL			1.3	4.3	5.8	1.3	6.8	
tPHZ	\overline{OE} or OE	Y	1.6	4.6	6.1	1.6	7.1	ns
tPLZ			1	3.9	5.4	1	5.9	

SN54ABT241A, SN74ABT241A
OCTAL BUFFERS/DRIVERS
WITH 3-STATE OUTPUTS

SCBS184B – JANUARY 1991 – MARCH 1996

PARAMETER MEASUREMENT INFORMATION

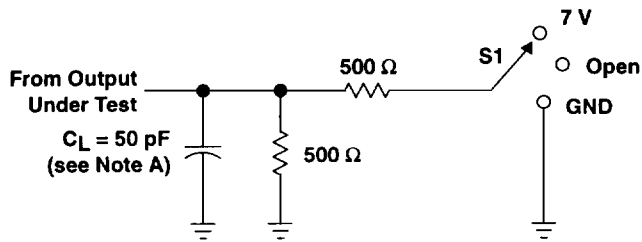

LOAD CIRCUIT FOR OUTPUTS

TEST	S1
t_{PLH}/t_{PHL}	Open
t_{PLZ}/t_{PZL}	7 V
t_{PHZ}/t_{PZH}	Open

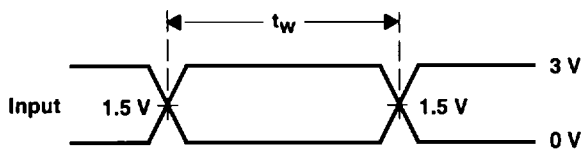

VOLTAGE WAVEFORMS
PULSE DURATION

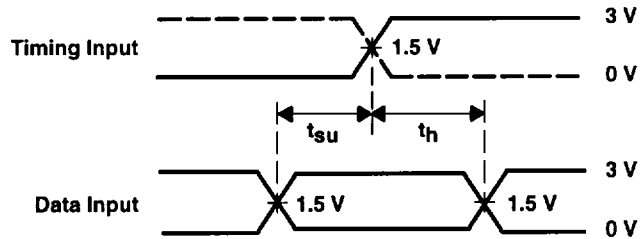

VOLTAGE WAVEFORMS
SETUP AND HOLD TIMES

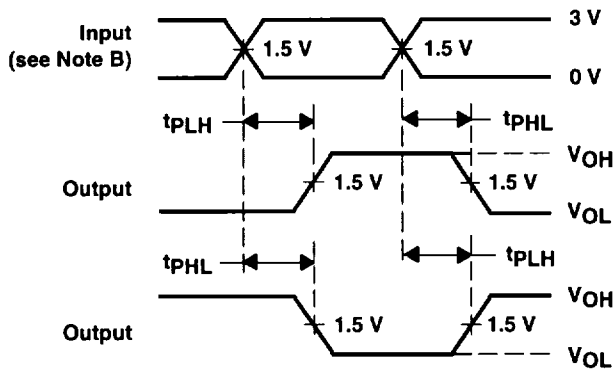

VOLTAGE WAVEFORMS
PROPAGATION DELAY TIMES
INVERTING AND NONINVERTING OUTPUTS

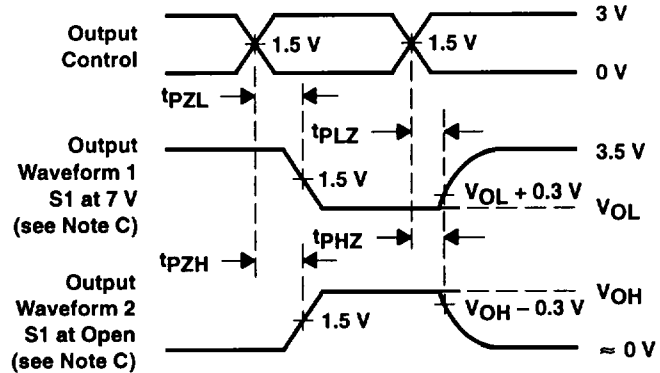

VOLTAGE WAVEFORMS
ENABLE AND DISABLE TIMES
LOW- AND HIGH-LEVEL ENABLING

- NOTES: A. C_L includes probe and jig capacitance.
 B. All input pulses are supplied by generators having the following characteristics: $PRR \leq 10$ MHz, $Z_O = 50 \Omega$, $t_r \leq 2.5$ ns, $t_f \leq 2.5$ ns.
 C. Waveform 1 is for an output with internal conditions such that the output is low except when disabled by the output control. Waveform 2 is for an output with internal conditions such that the output is high except when disabled by the output control.
 D. The outputs are measured one at a time with one transition per measurement.

Figure 1. Load Circuit and Voltage Waveforms