

National Semiconductor is now part of
Texas Instruments.

Search <http://www.ti.com/> for the latest technical
information and details on our current products and services.



NATL SEMICOND (LINEAR)

T-79-05-20

LM1558/LM1458 Dual Operational Amplifier

General Description

The LM1558 and the LM1458 are general purpose dual operational amplifiers. The two amplifiers share a common bias network and power supply leads. Otherwise, their operation is completely independent.

The LM1458 is identical to the LM1558 except that the LM1458 has its specifications guaranteed over the temperature range from 0°C to +70°C instead of -55°C to +125°C.

Features

- No frequency compensation required
- Short-circuit protection
- Wide common-mode and differential voltage ranges
- Low-power consumption
- 8-lead can and 8-lead mini DIP
- No latch up when input common mode range is exceeded

Schematic and Connection Diagrams

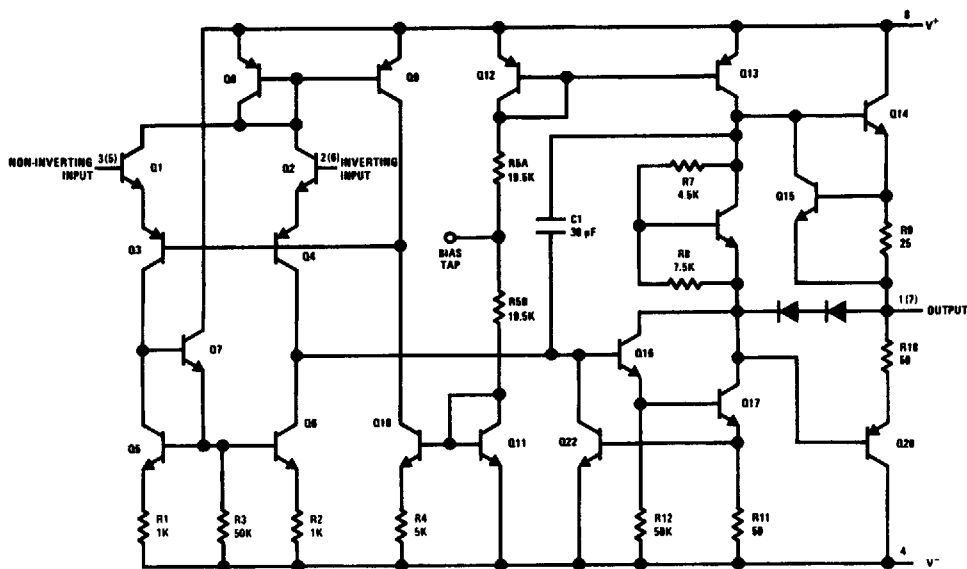

Note: Numbers in parentheses are pin numbers for amplifier B.

TL/H/7886-1

Metal Can Package

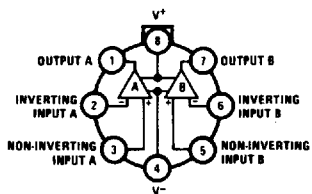

TL/H/7886-2

Top View

Order Number LM1558H,
LM1558H/883 or LM1458H
See NS Package Number H08C

Dual-In-Line Package

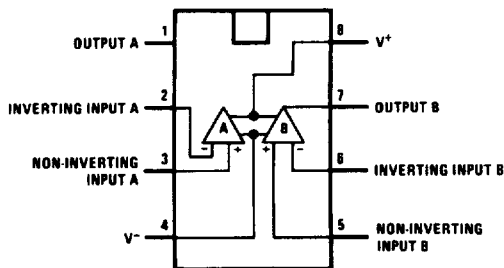

TL/H/7886-3

Top View

Order Number LM1558J, LM1558J/883, LM1458J, LM1458M or LM1458N
See NS Package Number J08A, M08A or N08E

NATL SEMICON (LINEAR)

Absolute Maximum Ratings

If Military/Aerospace specified devices are required, please contact the National Semiconductor Sales Office/Distributors for availability and specifications.

(Note 4)

Supply Voltage		
LM1558	±22V	
LM1458	±18V	
Power Dissipation (Note 1)		
LM1558H/LM1458H	500 mW	
LM1458N	400 mW	
Differential Input Voltage	±30V	
Input Voltage (Note 2)	±15V	
Output Short-Circuit Duration	Continuous	

Operating Temperature Range	
LM1558	-55°C to +125°C
LM1458	0°C to +70°C
Storage Temperature Range	-65°C to +150°C
Lead Temperature (Soldering, 10 sec.)	260°C
Soldering Information	
Dual-In-Line Package	
Soldering (10 seconds)	260°C
Small Outline Package	
Vapor Phase (60 seconds)	215°C
Infrared (15 seconds)	220°C
See AN-450 "Surface Mounting Methods and Their Effect on Product Reliability" for other methods of soldering surface mount devices.	
ESD tolerance (Note 5)	300V

Electrical Characteristics (Note 3)

Parameter	Conditions	LM1558			LM1458			Units
		Min	Typ	Max	Min	Typ	Max	
Input Offset Voltage	$T_A = 25^\circ\text{C}$, $R_S \leq 10\text{ k}\Omega$		1.0	5.0		1.0	6.0	mV
Input Offset Current	$T_A = 25^\circ\text{C}$		80	200		80	200	nA
Input Bias Current	$T_A = 25^\circ\text{C}$		200	500		200	500	nA
Input Resistance	$T_A = 25^\circ\text{C}$	0.3	1.0		0.3	1.0		M Ω
Supply Current Both Amplifiers	$T_A = 25^\circ\text{C}$, $V_S = \pm 15\text{V}$		3.0	5.0		3.0	5.6	mA
Large Signal Voltage Gain	$T_A = 25^\circ\text{C}$, $V_S = \pm 15\text{V}$ $V_{OUT} = \pm 10\text{V}$, $R_L \geq 2\text{ k}\Omega$	50	160		20	160		V/mV
Input Offset Voltage	$R_S \leq 10\text{ k}\Omega$			6.0			7.5	mV
Input Offset Current				500			300	nA
Input Bias Current				1.5			0.8	μA
Large Signal Voltage Gain	$V_S = \pm 15\text{V}$, $V_{OUT} = \pm 10\text{V}$ $R_L \geq \text{k}\Omega$	25			15			V/mV
Output Voltage Swing	$V_S = \pm 15\text{V}$, $R_L = 10\text{ k}\Omega$ $R_L = 2\text{ k}\Omega$	±12	±14		±12	±14		V
		±10	±13		±10	±13		V
Input Voltage Range	$V_S = \pm 15\text{V}$	±12			±12			V
Common Mode Rejection Ratio	$R_S \leq 10\text{ k}\Omega$	70	90		70	90		dB
Supply Voltage Rejection Ratio	$R_S \leq 10\text{ k}\Omega$	77	96		77	96		dB

Note 1: The maximum junction temperature of the LM1558 is 150°C, while that of the LM1458 is 100°C. For operating at elevated temperatures, devices in the H08 package must be derated based on a thermal resistance of 150°C/W, junction to ambient or 20°C/W, junction to case. For the DIP the device must be derated based on a thermal resistance of 187°C/W, junction to ambient.

Note 2: For supply voltages less than ±15V, the absolute maximum input voltage is equal to the supply voltage.

Note 3: These specifications apply for $V_S = \pm 15\text{V}$ and $-55^\circ\text{C} \leq T_A \leq 125^\circ\text{C}$, unless otherwise specified. With the LM1458, however, all specifications are limited to $0^\circ\text{C} \leq T_A \leq 70^\circ\text{C}$ and $V_S = \pm 15\text{V}$.

Note 4: Refer to RETS 1558V for LM1558J and LM1558H military specifications.

Note 5: Human body model, 1.5 k Ω in series with 100 pF.