

8192-word × 8-bit High Speed CMOS Static RAM

## Features

- Low-power standby
  - 0.1 mW (typ)
  - 10 μW (typ) L-/LL-version
- Low power operation
  - 15 mW/MHz (typ)
- Fast access time
  - 100/120/150 ns (max)
- Single +5 V supply
- Completely static memory
  - No clock or timing strobe required
- Equal access and cycle time
- Common data input and output, three-state output
- Directly TTL compatible
  - All inputs and outputs
- Battery back up operation capability (L-/LL-version)

## Ordering Information

Type No.	Access time	Package
HM6264AP-10	100 ns	600-mil, 28-pin plastic DIP (DP-28)
HM6264AP-12	120 ns	
HM6264AP-15	150 ns	
HM6264ALP-10	100 ns	
HM6264ALP-12	120 ns	
HM6264ALP-15	150 ns	
HM6264ALP-10L	100 ns	
HM6264ALP-12L	120 ns	
HM6264ALP-15L	150 ns	

Type No.	Access time	Package
HM6264ASP-10	100 ns	300-mil, 28-pin plastic DIP (DP-28N)
HM6264ASP-12	120 ns	
HM6264ASP-15	150 ns	
HM6264ALSP-10	100 ns	
HM6264ALSP-12	120 ns	
HM6264ALSP-15	150 ns	
HM6264ALSP-10L	100 ns	
HM6264ALSP-12L	120 ns	
HM6264ALSP-15L	150 ns	
HM6264AFP-10	100 ns	28-pin plastic SOP *1 (FP-28D/DA)
HM6264AFP-12	120 ns	
HM6264AFP-15	150 ns	
HM6264ALFP-10	100 ns	
HM6264ALFP-12	120 ns	
HM6264ALFP-15	150 ns	
HM6264ALFP-10L	100 ns	
HM6264ALFP-12L	120 ns	
HM6264ALFP-15L	150 ns	

Note: 1. T is added to the end of the type number for a SOP of 3.00 mm (max) thickness.

# HM6264A Series

## Pin Arrangement

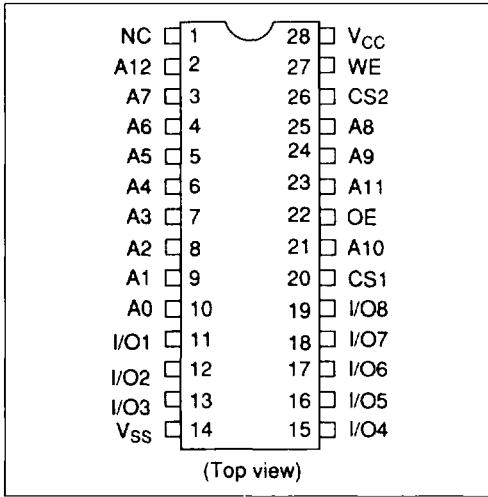

## Block Diagram

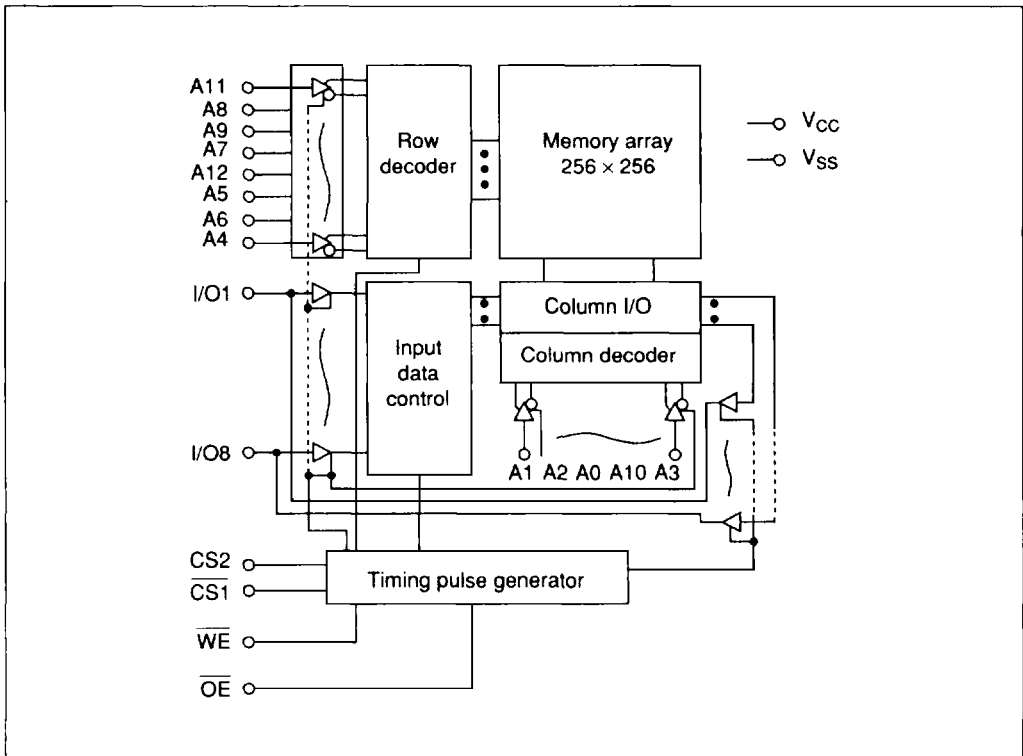

**HITACHI**

**Truth Table**

WE	CS1	CS2	OE	Mode	I/O pin	V <sub>CC</sub> current	Note
x	H	x	x	Not selected (power down)	High Z	I <sub>SB</sub> , I <sub>SB1</sub>	
x	x	L	x		High Z	I <sub>SB</sub> , I <sub>SB1</sub>	
H	L	H	H	Output disabled	High Z	I <sub>CC</sub>	
H	L	H	L	Read	Dout	I <sub>CC</sub>	Read cycle
L	L	H	H	Write	Din	I <sub>CC</sub>	Write cycle 1
L	L	H	L	Write	Din	I <sub>CC</sub>	Write cycle 2

x: Don't care.

**Absolute Maximum Ratings**

Parameter	Symbol	Rating	Unit
Terminal voltage *1	V <sub>T</sub>	-0.5 *2 to +7.0	V
Power dissipation	P <sub>T</sub>	1.0	W
Operating temperature	Topr	0 to +70	°C
Storage temperature	Tstg	-55 to +125	°C
Storage temperature (under bias)	Tbias	-10 to +85	°C

- Notes: 1. With respect to V<sub>SS</sub>.  
 2. -3.0 V for pulse width ≤ 50 ns

**Recommended DC Operating Conditions (Ta = 0 to +70°C)**

Parameter	Symbol	Min	Typ	Max	Unit
Supply voltage	V <sub>CC</sub>	4.5	5.0	5.5	V
	V <sub>SS</sub>	0	0	0	V
Input voltage	V <sub>IH</sub>	2.2	—	6.0	V
	V <sub>IL</sub>	-0.3 *1	—	0.8	V

- Note: 1. -3.0 V for pulse width ≤ 50 ns

## HM6264A Series

### DC and Operating Characteristics ( $V_{CC} = 5\text{ V} \pm 10\%$ , $V_{SS} = 0\text{ V}$ , $T_a = 0\text{ to }+70^\circ\text{C}$ )

Parameter	Symbol	Min	Typ	Max	Unit	Test condition
Input leakage current	$ I_{LI} $	—	—	2	$\mu\text{A}$	$V_{in} = V_{SS}\text{ to }V_{CC}$
Output leakage current	$ I_{LO} $	—	—	2	$\mu\text{A}$	$\overline{CS1} = V_{IH}\text{ or }CS2 = V_{IL}\text{ or }OE = V_{IH}\text{ or }WE = V_{IL}, V_{I/O} = V_{SS}\text{ to }V_{CC}$
Operating power supply current	$I_{CCDC}$	—	7	15	mA	$\overline{CS1} = V_{IL}, CS2 = V_{IH}, I_{I/O} = 0\text{ mA}$
Average operating current	$I_{CC1}$	—	30	45 <sup>*5</sup>	mA	Min. cycle, duty = 100%, $\overline{CS1} = V_{IL}, CS2 = V_{IH}, I_{I/O} = 0\text{ mA}$
	$I_{CC2}$	—	3	5	mA	Cycle time = 1 $\mu\text{s}$ , duty = 100%, $I_{I/O} = 0\text{ mA}, \overline{CS1} \leq 0.2\text{ V},$ $CS2 \geq V_{CC} - 0.2\text{ V}, V_{IH} \geq V_{CC} - 0.2\text{ V},$ $V_{IL} \leq 0.2\text{ V}$
Standby power supply current	$I_{SB}$	—	1	3	mA	$\overline{CS1} = V_{IH}\text{ or }CS2 = V_{IL}$
	$ISB1^{*2}$	—	0.02	2	mA	$\overline{CS1} \geq V_{CC} - 0.2\text{ V}, CS2 \geq V_{CC} - 0.2\text{ V}\text{ or}$
		—	2 <sup>*3</sup>	100 <sup>*3</sup>	$\mu\text{A}$	$0\text{ V} \leq CS2 \leq 0.2\text{ V}, 0\text{ V} \leq V_{in}$
		—	2 <sup>*4</sup>	50 <sup>*4</sup>		
Output voltage	$V_{OL}$	—	—	0.4	V	$I_{OL} = 2.1\text{ mA}$
	$V_{OH}$	2.4	—	—	V	$I_{OH} = -1.0\text{ mA}$

- Notes:
1. Typical values are at  $V_{CC} = 5.0\text{ V}$ ,  $T_a = 25^\circ\text{C}$  and not guaranteed.
  2.  $V_{IL\text{ min}} = -0.3\text{ V}$
  3. These characteristics are guaranteed only for the L-version.
  4. These characteristics are guaranteed only for the LL-version.
  5. For 120 ns/150 ns version.
  6. For 100 ns version.

### Capacitance ( $f = 1\text{ MHz}$ , $T_a = 25^\circ\text{C}$ )

Parameter	Symbol	Typ	Max	Unit	Test condition
Input capacitance	$C_{in}$	—	5	pF	$V_{in} = 0\text{ V}$
Input/output capacitance	$C_{I/O}$	—	7	pF	$V_{I/O} = 0\text{ V}$

Note: This parameter is sampled and is not 100% tested.

**HITACHI**

**AC Characteristics** ( $V_{CC} = 5\text{ V} \pm 10\%$ ,  $T_a = 0\text{ to }+70^\circ\text{C}$ )

**AC Test Conditions:**

- Input pulse levels: 0.8 V/2.4 V
- Input rise and fall time: 10 ns
- Input timing reference level: 1.5 V
- Output timing reference level
  - HM6264A-10: 1.5 V
  - HM6264A-12/15: 0.8 V/2.0 V
- Output load: 1 TTL gate and  $C_L$  (100 pF) (including scope and jig)

**Read Cycle**

Parameter	Symbol	HM6264A-10		HM6264A-12		HM6264A-15		Unit
		Min	Max	Min	Max	Min	Max	
Read cycle time	$t_{RC}$	100	—	120	—	150	—	ns
Address access time	$t_{AA}$	—	100	—	120	—	150	ns
Chip selection to output	$\overline{CS1}$ $t_{CO1}$	—	100	—	120	—	150	ns
	CS2 $t_{CO2}$	—	100	—	120	—	150	ns
Output enable to output valid	$t_{OE}$	—	50	—	60	—	70	ns
Chip selection to output in low Z	$\overline{CS1}$ $t_{LZ1}$	10	—	10	—	15	—	ns
	CS2 $t_{LZ2}$	10	—	10	—	15	—	ns
Output enable to output in low Z	$t_{OLZ}$	5	—	5	—	5	—	ns
Chip deselection to output in high Z	$\overline{CS1}$ $t_{HZ1}$	0	35	0	40	0	50	ns
	CS2 $t_{HZ2}$	0	35	0	40	0	50	ns
Output disable to output in high Z	$t_{OHZ}$	0	35	0	40	0	50	ns
Output hold from address change	$t_{OH}$	10	—	10	—	10	—	ns

- Notes
1.  $t_{HZ}$  and  $t_{OHZ}$  are defined as the time at which the outputs to achieve the open circuit condition and are not referred to output voltage levels.
  2. At any given temperature and voltage condition,  $t_{HZ}$  maximum is less than  $t_{LZ}$  minimum both for a given device and from device to device.



# HM6264A Series

## Read Timing Waveform

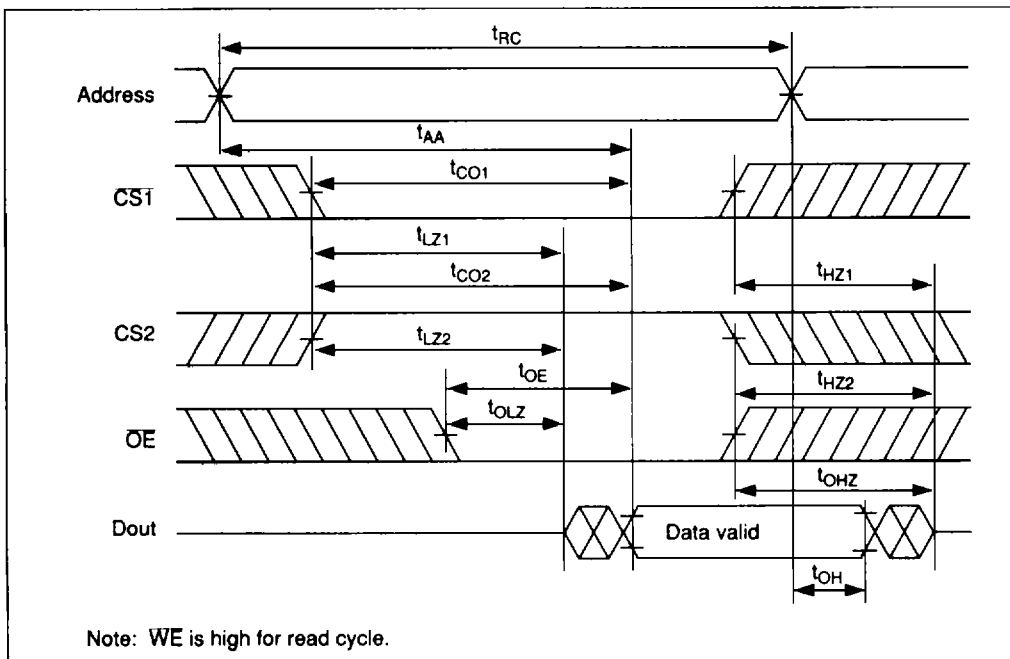

## Write Cycle

Parameter	Symbol	HM6264A-10		HM6264A-12		HM6264A-15		Unit
		Min	Max	Min	Max	Min	Max	
Write cycle time	$t_{WC}$	100	—	120	—	150	—	ns
Chip selection to end of write	$t_{CW}$	80	—	85	—	100	—	ns
Address setup time	$t_{AS}$	0	—	0	—	0	—	ns
Address valid to end of write	$t_{AW}$	80	—	85	—	100	—	ns
Write pulse width	$t_{WP}$	60	—	70	—	90	—	ns
Write recovery time	$t_{WR}$	0	—	0	—	0	—	ns
Write to output in high Z	$t_{WHZ}$	0	35	0	40	0	50	ns
Data to write time overlap	$t_{DW}$	40	—	40	—	50	—	ns
Data hold from write time	$t_{DH}$	0	—	0	—	0	—	ns
Output enable to output in high Z	$t_{OHZ}$	0	35	0	40	0	50	ns
Output active from end of write	$t_{OW}$	5	—	5	—	5	—	ns

HITACHI

Write Timing Waveform (1) ( $\overline{OE}$  Clock)

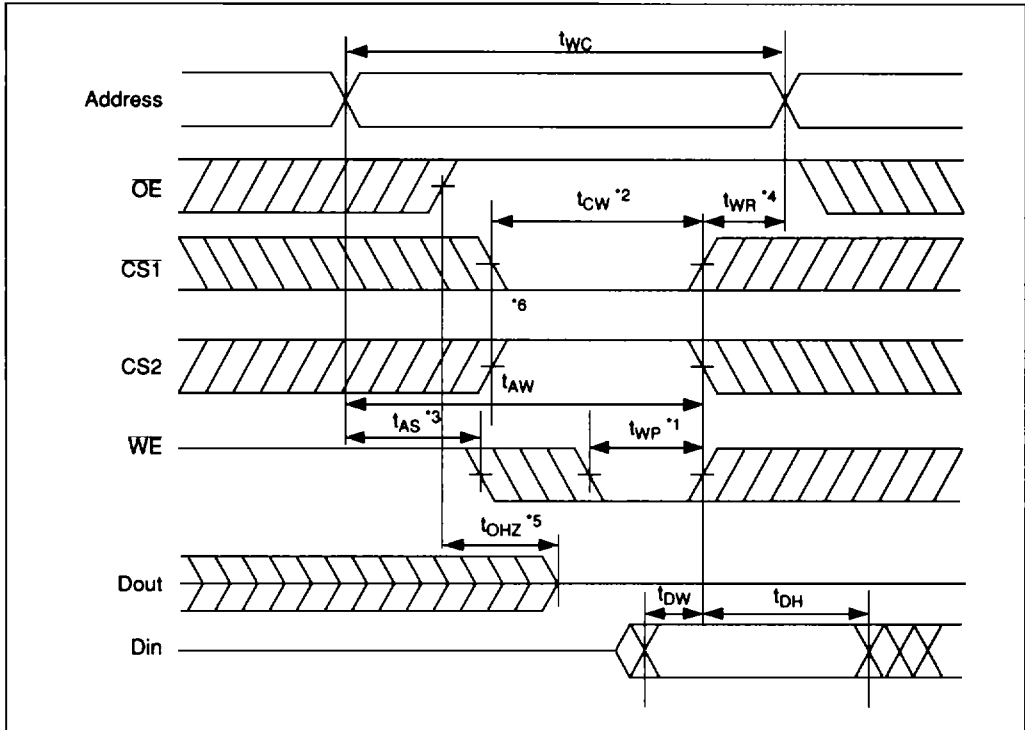

# HM6264A Series

## Write Timing Waveform (2) ( $\overline{OE}$ Low Fix)

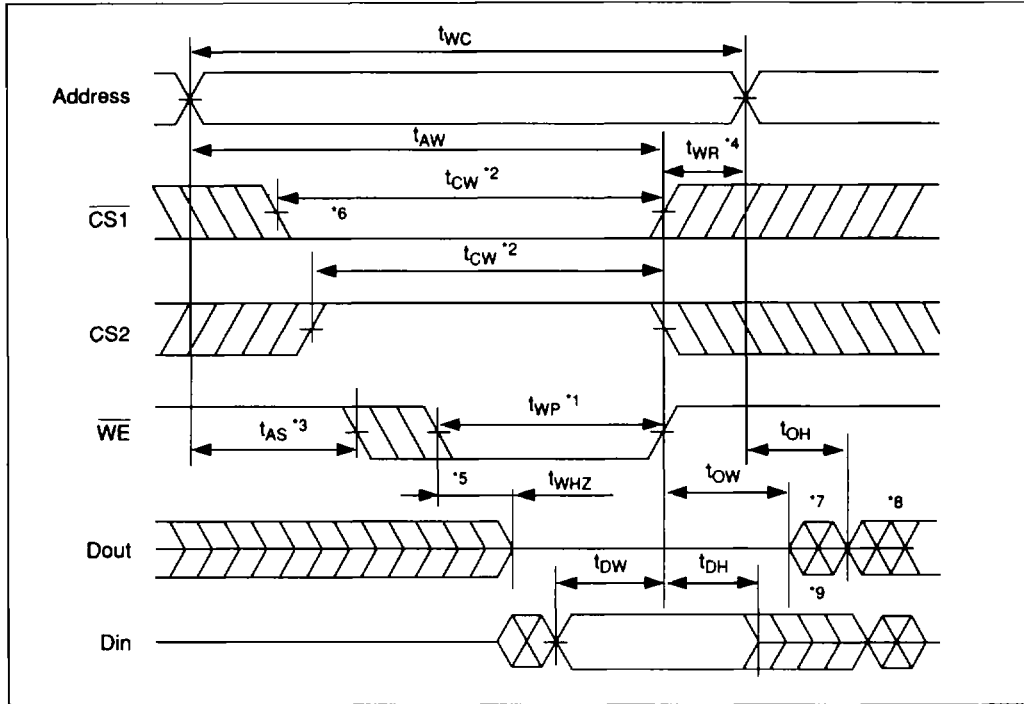

- Notes:
1. A write occurs during the overlap of a low  $\overline{CS1}$ , a high  $\overline{CS2}$ , and a low  $\overline{WE}$ . A write begins at the latest transition among  $\overline{CS1}$  going low,  $\overline{CS2}$  going high and  $\overline{WE}$  going low. A write ends at the earliest transition among  $\overline{CS1}$  going high,  $\overline{CS2}$  going low and  $\overline{WE}$  going high. Time  $t_{WP}^1$  is measured from the beginning of write to the end of write.
  2.  $t_{CW}^2$  is measured from the later of  $\overline{CS1}$  going low or  $\overline{CS2}$  going high to the end of write.
  3.  $t_{AS}^3$  is measured from the address valid to the beginning of write.
  4.  $t_{WR}^4$  is measured from the earliest of  $\overline{CS1}$  or  $\overline{WE}$  going high or  $\overline{CS2}$  going low to the end of the write cycle.
  5. During this period, I/O pins are in the output state, therefore the input signals of opposite phase to the outputs must not be applied.
  6. If  $\overline{CS1}$  goes low simultaneously with  $\overline{WE}$  going low or after  $\overline{WE}$  goes low, the outputs remain in high impedance state.
  7.  $\overline{Dout}$  is the same phase of the latest written data in this write cycle.
  8.  $\overline{Dout}$  is the read data of the next address.
  9. If  $\overline{CS1}$  is low and  $\overline{CS2}$  is high during this period, I/O pins are in the output state. Input signals of opposite phase to the outputs must not be applied to I/O pins

HITACHI



**Low  $V_{CC}$  Data Retention**

In data retention mode, CS2 controls the address,  $\overline{WE}$ ,  $\overline{CS1}$ ,  $\overline{OE}$ , and the Din buffer. If CS2 controls data retention mode, Vin (for these inputs) can be in the high impedance state. If CS1 controls the data retention mode, CS2 must satisfy either

$CS2 \geq V_{CC} - 0.2 \text{ V}$  or  $CS2 \leq 0.2 \text{ V}$ . The other input levels (address,  $\overline{WE}$ ,  $\overline{OE}$ , I/O) can be in the high impedance state.

**Low  $V_{CC}$  Data Retention Characteristics ( $T_a = 0$  to  $+70^\circ\text{C}$ )**

This characteristics is guaranteed only L/LL-version.

Parameter	Symbol	Test Condition	Min	Typ	Max	Unit
$V_{CC}$ for data retention	$V_{DR}$	$\overline{CS1} \geq V_{CC} - 0.2 \text{ V}$ , $CS2 \geq V_{CC} - 0.2 \text{ V}$ , or $CS2 \leq 0.2 \text{ V}$	2.0	—	—	V
Data retention current	$I_{CCDR}$	$V_{CC} = 3.0 \text{ V}$ , $\overline{CS1} \geq V_{CC} - 0.2 \text{ V}$ , $CS2 \geq V_{CC} - 0.2 \text{ V}$ , or $0 \text{ V} \leq CS2 \leq 0.2 \text{ V}$ , $0 \text{ V} \leq V_{in}$	—	1 <sup>1</sup>	50 <sup>1</sup>	$\mu\text{A}$
Chip deselect to data retention time	$t_{CDR}$	See retention waveform	0	—	—	ns
Operation recovery time	$t_R$	See retention waveform	$t_{RC}$ <sup>3</sup>	—	—	ns

- Notes:
- $V_{IL}$  min =  $-0.3 \text{ V}$ ,  $20 \mu\text{A}$  max at  $T_a = 0$  to  $40^\circ\text{C}$ . These characteristics are guaranteed only for the L-version.
  - $V_{IL}$  min =  $-0.3 \text{ V}$ ,  $10 \mu\text{A}$  max at  $T_a = 0$  to  $40^\circ\text{C}$ . These characteristics are guaranteed only for the LL-version.
  - $t_{RC}$  = Read cycle time.

**Low  $V_{CC}$  Data Retention Waveform (1) ( $\overline{CS1}$  Controlled)**

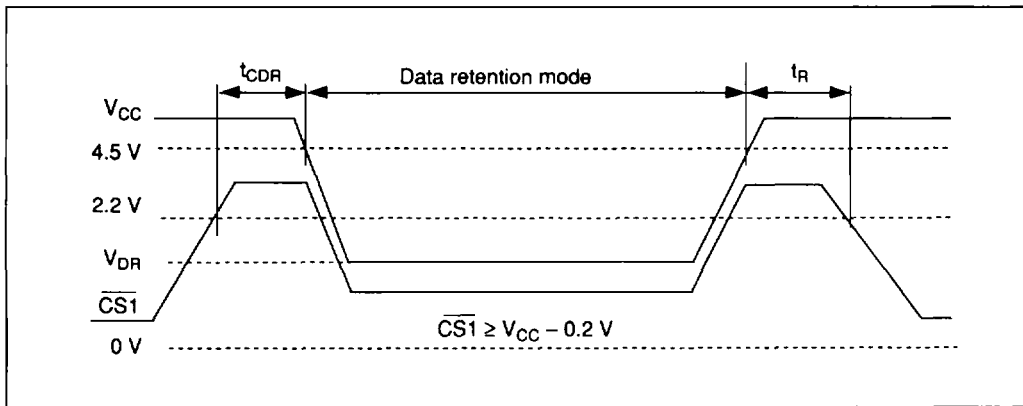

# HM6264A Series

## Low $V_{CC}$ Data Retention Waveform (2) ( $\overline{CS2}$ Controlled)

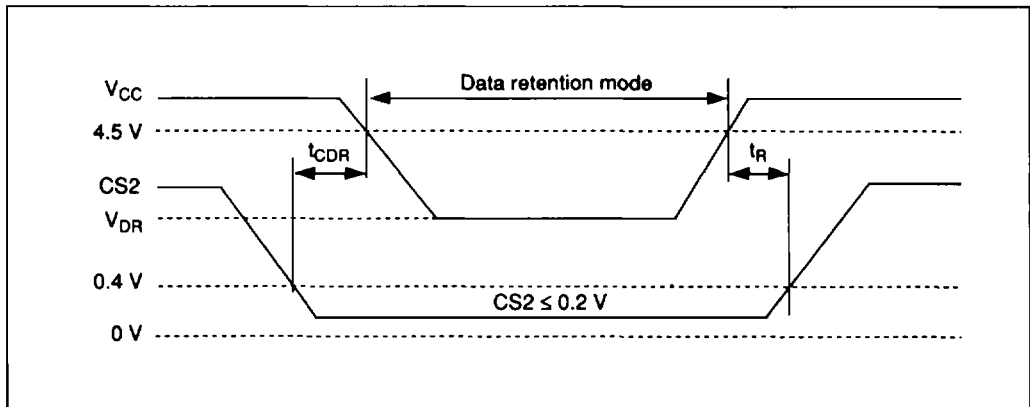

**HITACHI**