

Gigabit Interface Converters Transceiver Module for Gigabit Ethernet

FEATURES

- Compliant with IEEE802.3z/D2 Gigabit Ethernet (1000BASE-LX) Specification
- Giga-bit Inetrface Converter(GBIC) Revision 5.4 compliant [4]
- Data Link up to 5km (GBIC-1250B3I) or 10km (GBIC-1250B3Q) on Single Mode Fiber.
- Single + 5V Power Supply and TTL Logic Interface
- Hot pluggable
- Laser Class 1 Product (Laser Klasse 1 Product) which comply with the requirements of IEC 60825-1 and IEC 60825-2

Absolute Maximum Ratings

Parameter	Symbol	Min.	Typ.	Max.	Unit	Reference
Storage temperature	T _s	-40		85	°C	
Supply voltage	V _{CC}	0		6	V	

Recommended Operating Conditions:

Parameter	Symbol	Min.	Typ.	Max.	Unit	Reference
Ambient Operating Temperature	T _A	-40		85	°C	
Supply voltage	V _{CC}	4.75		5.25	V	
Transmitter Data input voltage-Low	V _{IL} - V _{CC}	-1.810		-1.475	V	
Transmitter Data input voltage-High	V _{IH} - V _{CC}	-1.165		-0.880	V	
Transmitter Differential Input Voltage	V _D			2	V	
Data Output Load	R _{DL}		75		Ω	

 DELTA ELECTRONICS, INC.	TITLE			DATE:	
	GBIC-1250B3 I/Q				
	WRITTEN	CHECKED	APPROVED	DOCUMENT NO:	REV:
	JasonWang	Weizen.Lo	Teddy.Kuo		

Gigabit Interface Converters Transceiver Module for Gigabit Ethernet

Transmitter Electro-Optical Performance Specifications:

Parameter	Symbol	Min.	Typ.	Max.	Unit	Reference
Supply current	I _{cc}			160	mA	
Launched power(avg.) GBIC-1250B3I GBIC-1250B3Q	P _o	-11 -9.5		-3 -3	dBm	Note(1)
Optical extinction ratio		9			dB	Note(1)
Center wavelength	λ _c	1274	1310	1355	nm	
Spectral width(RMS)	σ			4	nm rms	
Relative Intensity Noise	RIN			-120	dB/Hz	

Note(1).The maximum optical output power complies with the IEEE 802.3z/D2 specification, and is class 1 laser eye safe.

Receiver Electro-Optical Performance Specifications:

Parameter	Symbol	Min.	Typ.	Max.	Unit	Reference
Supply current	I _{cc}			130	mA	
Data output voltage-Low	V _{OL} - V _{CC}	-1.950		-1.620	V _{CC}	
Data output voltage-High	V _{OH} - V _{CC}	-1.045		-0.740	V _{CC}	
Optical input sensitivity(avg.)	P _{IN}			-19	dBm	Note(1)
Optical input saturation(avg.)	P _{SAT}	-3			dBm	Note(1)
Optical wavelength	λ		1310		nm	
Output Data risetime	t _r			0.4	ns	Note(2)
Output Data falltime	t _f			0.4	ns	Note(2)
Signal detect-Assert	P _A			-20	dBm	
Signal detect-Deassert	P _D	-35			dBm	
Signal detect-Hysteresis	P _A -P _D	0.5			dB	

Note(1).With BER better than or equal to 1x10⁻¹²,measured in the center of the eye opening with 2²³-1 NRZ PRBS

Note(2).These are 20%~80% values

 DELTA ELECTRONICS, INC.	TITLE			DATE:	
	GBIC-1250B3 I/Q				
	WRITTEN	CHECKED	APPROVED	DOCUMENT NO:	REV:
	JasonWang	Weizen.Lo	Teddy.Kuo		

Gigabit Interface Converters Transceiver Module for Gigabit Ethernet

GBIC to host connector pin assignment

Pin Name	Pin#	Sequence	Sequence	Pin#	Pin Name
RX_LOS	1	2	1	11	RGND
RGND	2	2	1	12	-RX_DAT
RGND	3	2	1	13	+RX_DAT
MOD_DEF(0)	4	2	1	14	RGND
MOD_DEF(1)	5	2	2	15	VDDR
MOD_DEF(2)	6	2	2	16	VDDT
TX_DISABLE	7	2	1	17	TGND
TGND	8	2	1	18	+TX_DAT
TGND	9	2	1	19	-TX_DAT
TX_FAULT	10	2	1	20	TGND

Overview of internal interface signal Definition

Pin Name	Pin #	Name/Function	Signal Specification
Receiver Signals			
RGND	2,3,11,14	Receiver Ground (may be connected with TGND in GBIC)	Ground, to GBIC
VDDR	15	Receiver +5 volt (may be connected with VDDT in GBIC)	Power, to GBIC
-RX_DAT	12	Receive Data, Differential PECL	High speed serial, from GBIC
+RX_DAT	13	Receive Data, Differential PECL	High speed serial, from GBIC
RX_LOS	1	Receiver Loss of Signal, logic high, open collector compatible, 4.7 K to 10 K Ohm pull up to VDDT on host	Low speed, from GBIC
Transmitter Signals			
TGND	8,9,17,20	Transmitter Ground (may be connected with RGND internally)	Ground, to GBIC
VDDT	16	Transmitter +5 volt(may be connected with VDDR in GBIC)	Power, to GBIC
+TX_DAT	18	Transmit Data, Differential PECL	High speed serial, to GBIC
-TX_DAT	19	Transmit Data, Differential PECL	High speed serial, to GBIC
TX_DISABLE	7	Transmitter Disable, logic high, open collector compatible, 4.7 K to 10 K Ohm pull up to VDDT on GBIC	Low speed, to GBIC
TX_FAULT	10	Transmitter Fault, logic high, open collector compatible, 4.7 K to 10 K Ohm pull up to VDDT on host	Low speed, from GBIC
Control Signals			
MOD_DEF(0)	4	GBIC module definition and presence, bit 0, 4.7 K to 10 K Ohm pull up to VDDT on host	Low speed, from GBIC
MOD_DEF(1)	5	GBIC module definition and presence, bit 1, 4.7 K to 10 K Ohm pull up to VDDT on host	Low speed, from GBIC
MOD_DEF(2)	6	GBIC module definition and presence, bit 2, 4.7 K to 10 K Ohm pull up to VDDT on host	Low speed, from GBIC

 DELTA ELECTRONICS, INC.	TITLE			DATE:	
	GBIC-1250B3 I/Q				
	WRITTEN	CHECKED	APPROVED	DOCUMENT NO:	REV:
	JasonWang	Weizen.Lo	Teddy.Kuo		

Gigabit Interface Converters Transceiver Module for Gigabit Ethernet

Recommended Circuit Schematic :

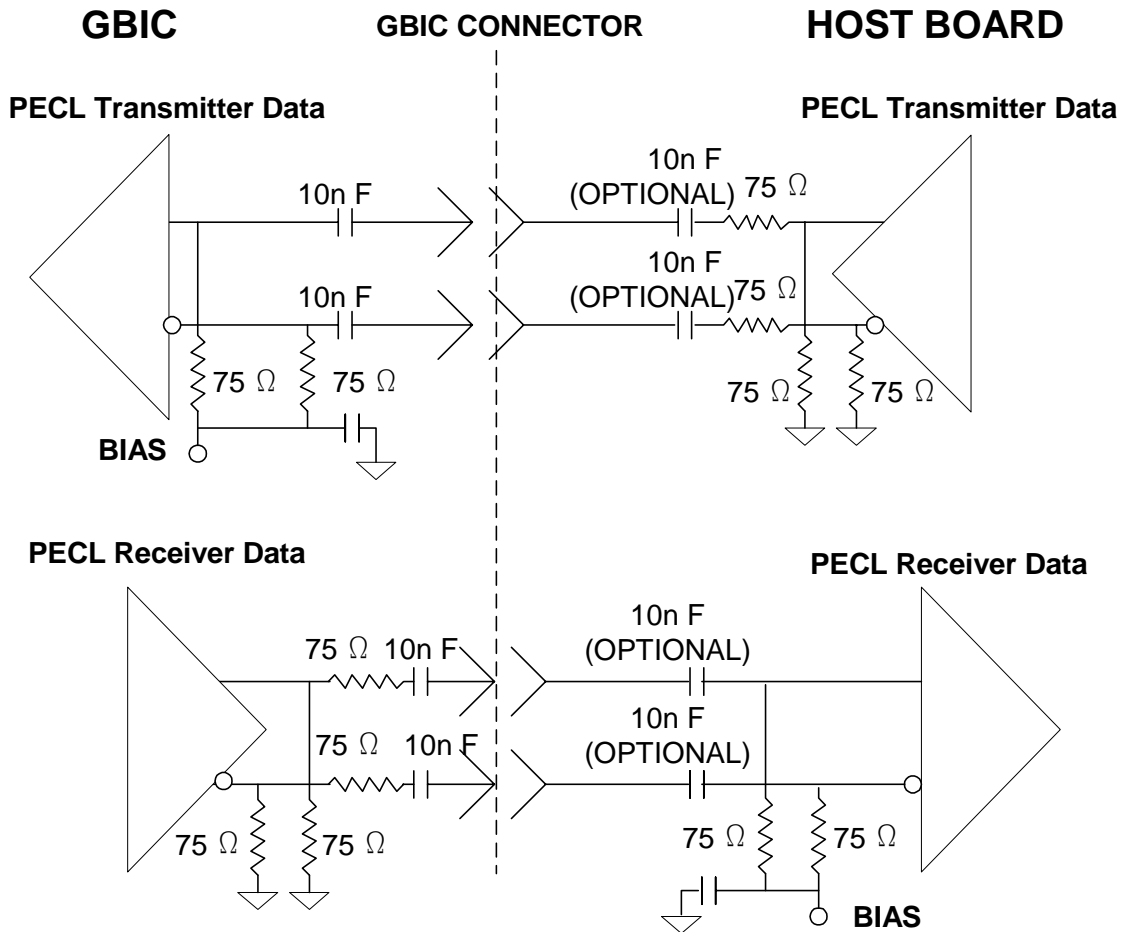

 DELTA DELTA ELECTRONICS, INC.	TITLE			DATE:	
	GBIC-1250B3 I/Q				
	WRITTEN	CHECKED	APPROVED	DOCUMENT NO:	
			JasonWang	Weizen.Lo	Teddy.Kuo

Gigabit Interface Converters Transceiver Module for Gigabit Ethernet

GBIC module definition parameters :

Module Definition	MOD_DEF(0) pin 4	MOD_DEF(1) pin 5	MOD_DEF(2) pin 6	Interpretation by host Reference
0	NC	NC	NC	GBIC not present clause
1	NC	NC	TTL LOW	Copper Style 1 or Style 2 connector, 1.0625 Gbd, 100-TW-EL-S or 100-TP-EL-S, active inter-enclosure connection. and IEEE802.3 1000BASE-CX
2	NC	TTL LOW	NC	Copper Style 1 or Style 2 connector, 1.0625 Gbd, 100-TW-EL-S, or 100-TP-EL-S, active or passive intraenclosure connection
3	NC	TTL LOW	TTL LOW	Optical LW, 1.0625 Gbd 100-SM-LC-L
4	TTL LOW	SCL	SDA	Serial module definition protocol
5	TTL LOW	NC	TTL LOW	Optical SW, 1.0625 Gbd 100-M5-SN-I or 100-M6-SN-I
6	TTL LOW	TTL LOW	NC	Optical LW, 1.0625 Gbd 100-SM-LC-L and similar to 1.25 Gbd IEEE802.3z 1000BASE-LX, single mode
7	TTL LOW	TTL LOW	TTL LOW	Optical SW, 1.0625 Gbd 100-M5-SN-I or 100-M6-SN-I and 1.25 Gbd, IEEE 802.3z, 1000BASE-SX

GBIC timing parameters for GBIC management

Parameter	Symbol	Min.	Max.	Unit	Unit Conditions
TX_DISABLE assert time	t_off		10	μsec	rising edge of TX_DISABLE to fall of output signal below 10% of nominal
TX_DISABLE negate time	t_on		1	mec	Falling edge of TX_DISABLE to rise of output signal above 90% of nominal
Time to initialize, includes reset of TX_FAULT	t_init		300	msec	From power on or hot plug after V DD T > 4.75 volts or From negation of TX_DISABLE during reset of TX_FAULT.
TX_FAULT from fault to assertion	t_fault		100	μsec	From occurrence of fault (out-put safety violation or V DD T < 4.5 volts)
TX_DISABLE time to start reset	t_rest	10		μsec	TX_DISABLE HIGH before TX_DISABLE set LOW
RX_LOS assert delay	t_loss_on		100	μsec	From detection of loss of signal to assertion of RX_LOS
RX_LOS negate delay	t_loss_off		100	μsec	From detection of presence of signal to negation of RX_LOS

 DELTA ELECTRONICS, INC.	TITLE			DATE:	
	GBIC-1250B3 I/Q				
	WRITTEN	CHECKED	APPROVED	DOCUMENT NO:	REV:
	JasonWang	Weizen.Lo	Teddy.Kuo		

Gigabit Interface Converters Transceiver Module for Gigabit Ethernet

GBIC timing parameters :

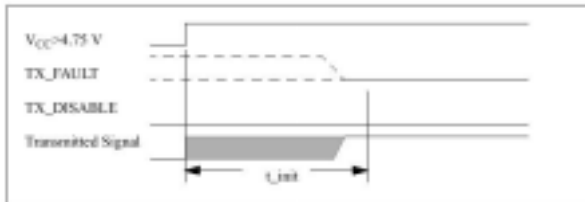

Power on initialization of GBIC, TX_DISABLE negated

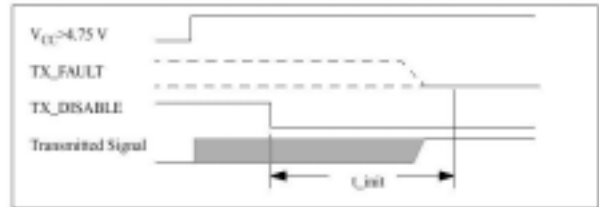

Power on initialization of GBIC, TX_DISABLE asserted

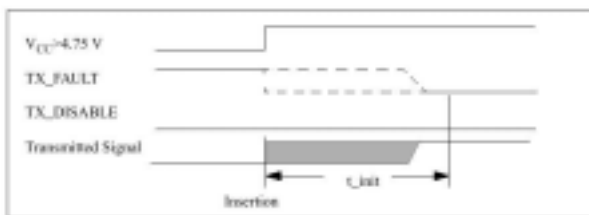

Example of initialization during hot plugging, TX_DISABLE negated

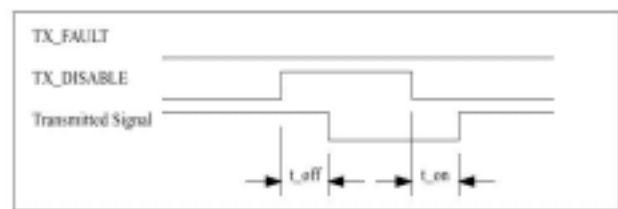

Management of GBIC during normal operation, TX_DISABLE implemented

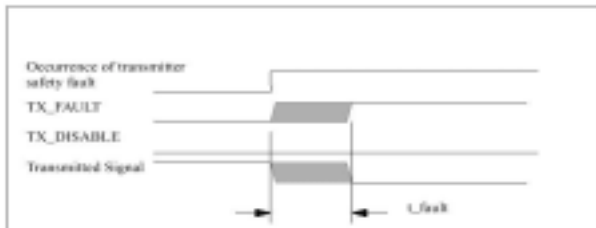

Detection of transmitter safety fault condition

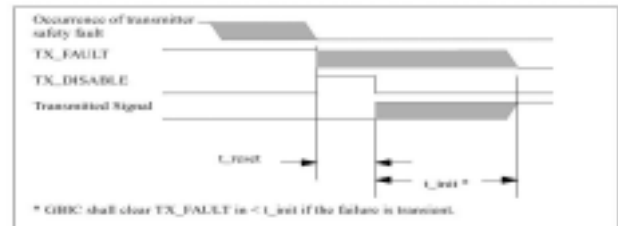

Successful recovery from transient safety fault condition

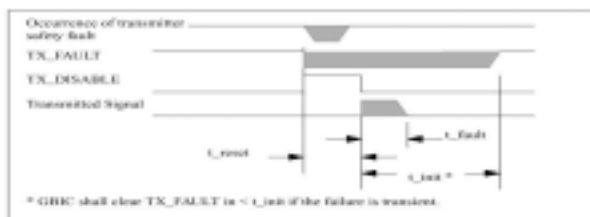

Unsuccessful recovery from safety fault condition



Timing of RX_LOS detection

 DELTA ELECTRONICS, INC.	TITLE			DATE:	
	GBIC-1250B3 I/Q				
	WRITTEN	CHECKED	APPROVED	DOCUMENT NO:	
	JasonWang	Weizen.Lo	Teddy.Kuo		

Gigabit Interface Converters Transceiver Module for Gigabit Ethernet

Serial ID Identification

A GBIC having module definition 4 provides access to sophisticated identification information that describes the GBIC's capabilities, standard interfaces, manufacturer, and other information. The serial interface uses the 2-wire serial CMOS E 2 PROM protocol defined for the ATMEL AT24C 01A/02/04 family of components (see 5.2.1). The memories are organized as a series of 8-bit data words that can be addressed individually or sequentially.

Data Address	Field Size (Bytes)	Name of field	Description of field
BASE OF FIELDS			
0	1	Identifier	Type of serial transceiver (see table D.2)
1	1	Ext. Identifier	Extended identifier of type of serial transceiver (See table D.3)
2	1	Connector	Code for connector type (see table D.4)
3-10	8	Transceiver	Code for electronic compatibility or optical compatibility (see table D.5)
11	1	Encoding	Code for serial encoding algorithm (see table D.6)
12	1	BR, Nominal	Nominal bit rate, units of 100 MBits/sec.
13-14	2	Reserved	
15	1	Length (9μ)	Link length supported for 9/125 mm fiber, units of 100 m
16	1	Length (50μ)	Link length supported for 50/125 mm fiber, units of 10 m
17	1	Length (62.5μ)	Link length supported for 62.5/125 mm fiber, units of 10 m
18	1	Length (Copper)	Link length supported for copper, units of meters
19	1	Reserved	
20-35	16	Vendor name	GBIC vendor name (ASCII)
36	1	Reserved	
37-39	3	Vendor OUI	GBIC vendor IEEE company ID
40-55	16	Vendor PN	Part number provided by GBIC vendor (ASCII)
56-59	4	Vendor rev	Revision level for part number provided by vendor (ASCII)
60-62	3	Reserved	
63	1	CC BASE	Check code for Base ID Fields (addresses 0 to 62)
EXTENDED ID FIELDS			
64-65	2	Options	Indicates which optional GBIC signals are implemented (see table D.7)
66	1	BR, max	Upper bit rate margin, units of %
67	1	BR, min	Lower bit rate margin, units of %
68-83	16	Vendor SN	Serial number provided by vendor (ASCII)
84-91	8	Date code	Vendor's manufacturing date code (see table D.8)
92-94	3	Reserved	
95	1	CC EXT	Check code for the Extended ID Fields (addresses 64 to 94)
VENDOR SPECIFIC ID FIELDS			
96-127	32	Read-only	Vendor specific data, read only
128-511	384	Reserved	
512-n			Vendor specific

Table D.1 : Serial ID Data Field

 DELTA ELECTRONICS, INC.	TITLE			DATE:	
	GBIC-1250B3 I/Q				
	WRITTEN	CHECKED	APPROVED	DOCUMENT NO:	REV:
	JasonWang	Weizen.Lo	Teddy.Kuo		

Gigabit Interface Converters Transceiver Module for Gigabit Ethernet

Identifier

The identifier value specifies the physical device described by the serial information. This value shall be included in the serial data. The defined identifier values are shown in **table D.2**.

Value	Description of physical device
00h	Unknow or unspecified
01h	GBIC
02h	Module/connector soldered to motherboard
03-7Fh	Reserved
80-FFh	Vendor specific

Table D.2 : Identifier values

Extended Identifier

The extended identifier value provides additional information about the transceiver. At present, extended identifier values are specified only for the identifier value of 01h (GBIC). The Extended Identifier value is reserved for all other identifier values. The defined extended identifier values for the GBIC are shown in **table D.3**.

Value	Description of physical device
00h	GBIC definition is not specified or the GBIC definition is not compliant with a defined MOD_DEF. See product specification for details.
01h	GBIC is compliant with MOD_DEF 1
02h	GBIC is compliant with MOD_DEF 2
03h	GBIC is compliant with MOD_DEF 3
04h	GBIC function is defined by serial ID only
05h	GBIC is compliant with MOD_DEF 5
06-7Fh	Reserved
80-FFh	Vendor specific

Table D.3 : Extended Identifier values for Identifier 01h (GBIC)

 DELTA ELECTRONICS, INC.	TITLE			DATE:	
	GBIC-1250B3 I/Q				
	WRITTEN	CHECKED	APPROVED	DOCUMENT NO:	REV:
	JasonWang	Weizen.Lo	Teddy.Kuo		

Gigabit Interface Converters Transceiver Module for Gigabit Ethernet

Connector

The Connector value indicates the external connector provided on the interface. This value shall be included in the serial data. The defined connector values are shown in **table D.4**.

Value	Description of physical device
00h	Unknow or unspecified
01h	Fibre Channel definition of SC connector
02h	Fibre Channel definition of style 1 copper connector
03h	Fibre Channel definition of style 2 copper connector
04h	Fibre Channel definition of BNC/TNC
05h	Fibre Channel definition of coaxial headers
06h-7Fh	Reserved
05h-FFh	Vendor specific

Table D.4 : Connector values

 DELTA ELECTRONICS, INC.	TITLE			DATE:	
	GBIC-1250B3 I/Q				
	WRITTEN	CHECKED	APPROVED	DOCUMENT NO:	REV:
	JasonWang	Weizen.Lo	Teddy.Kuo		

Gigabit Interface Converters Transceiver Module for Gigabit Ethernet

Transceiver

The following bit significant indicators define the electronic or optical interfaces that are supported by the GBIC. At least one bit shall be set in this field. For Fibre Channel GBICs, the Fibre Channel speed, transmission media, transmitter technology, and distance capability shall all be indicated. The defined transceiver values are shown in **table D.5**.

Data Addr	Bit	Description of transceiver	Data Addr	Bit	Description of transceiver
Reserved Standard Compliance Codes			Fibre Channel link length		
3	7-0	Reserved	7	7	Reserved
4	7-0	Reserved	7	6	short distance (S)
SONET Compliance Codes			7	5	intermediate distance (I)
5	7	Reserved	7	4	long distance (L)
5	6	OC 12, single mode long reach	Fibre Channel transmitter technology		
5	5	OC 12, single mode intermediate reach	7	3-2	Reserved
5	4	OC 12 multi-mode short reach	7	1	Longwave laser (LC)
5	3	Reserved	7	0	Electrical inter-enclosure (EL)
5	2	OC 3, single mode long reach	8	7	Electrical intra-enclosure (EL)
5	1	OC 3, single mode intermediate reach	8	6	Shortwave laser w/o OFC (SN)
5	0	OC 3, multi-mode short reach	8	5	Shortwave laser w/ OFC (SL)
Gigabit Ethernet Compliance Codes			8	4	
6	7-4	Reserved	Fibre Channel transmission media		
6	3	1000BASE-T 8 0-3 Reserved	8	0-3	Reserved
6	2	1000BASE-CX	9	7	Twin Axial Pair (TW)
6	1	1000BASE-LX	9	6	Shielded Twisted Pair (TP)
6	0	1000BASE-SX	9	5	Miniature Coax (MI)
			9	4	Video Coax (TV)
			9	3	Multi-mode, 62.5 μ (M6)
			9	2	Multi-mode, 50 μ (M5)
			9	1	Reserved
			9	0	Single Mode (SM)
			Fibre Channel speed		
			10	7-5	Reserved
			10	4	400 MBytes/Sec
			10	3	Reserved
			10	2	200 MBytes./Sec
			10	1	Reserved
			10	0	100 MBytes./Sec

a. Bit 7 is the high order bit and is transmitted first in each byte.

Table D.5: Transceiver codes

 DELTA ELECTRONICS, INC.	TITLE			DATE:	
	GBIC-1250B3 I/Q				
	WRITTEN	CHECKED	APPROVED	DOCUMENT NO:	REV:
	JasonWang	Weizen.Lo	Teddy.Kuo		

Gigabit Interface Converters Transceiver Module for Gigabit Ethernet

Mechanical Dimensions

Unit : mm

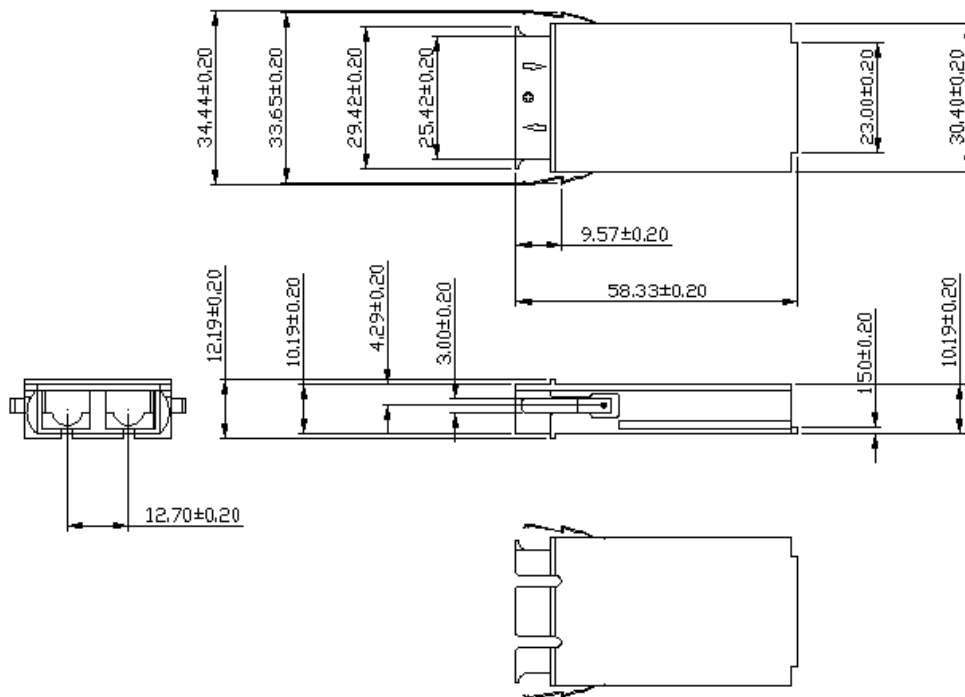

 DELTA ELECTRONICS, INC.	TITLE			DATE:	
	GBIC-1250B3 I/Q				
	WRITTEN	CHECKED	APPROVED	DOCUMENT NO:	REV:
	JasonWang	Weizen.Lo	Teddy.Kuo		

Gigabit Interface Converters Transceiver Module for Gigabit Ethernet

Regulatory Compliance

Test Item	Reference	Qty'	Evaluation
#1) Electromagnetic Interference EMI	FCC Class B	5	(1) Satisfied with electrical characteristics of product spec. (2) No physical damage
	EN 55022 Class B		
	CISPR 22		
#2) Immunity : Radio Frequency Electromagnetic Field	EN 61000-4-3	5	
	IEC 1000-4-3		
#3) Immunity : Electrostatic Discharge to the Duplex SC Receptacle	EN 61000-4-2	5	
	IEC 1000-4-2		
	IEC 801.2		
#4) Electrostatic Discharge to the Electrical Pins	MIL-STD-883C Method 3015.4	5	
	EIAJ#1988.3.2B Version 2, Machine model		

 DELTA ELECTRONICS, INC.	TITLE			DATE:	
	GBIC-1250B3 I/Q				
	WRITTEN	CHECKED	APPROVED	DOCUMENT NO:	REV:
JasonWang	Weizen.Lo	Teddy.Kuo			