

*** DHSL ***

Material:

- * Insulator : UL94V-0 PBT.
- * Contact : Phosphor Bronze.
- * Plating : Gold flash over nickel.

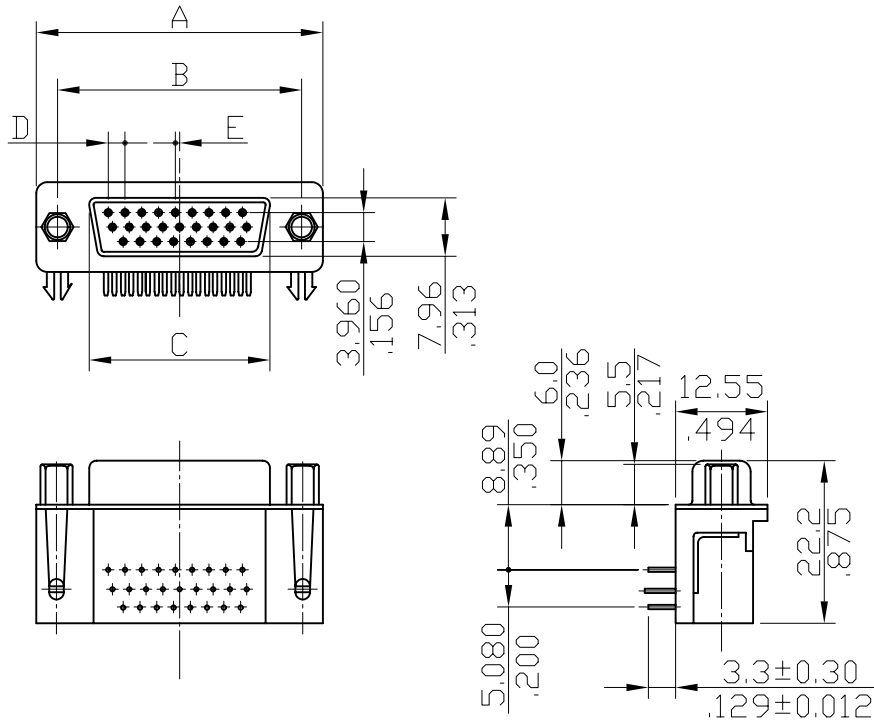

DHSL-62	62	69.3(2.792)	57.73(2.273)	54.84(2.159)	2.410(.095)	0.58(.023)
DHSL-44	44	53.0(2.088)	41.28(1.625)	38.38(1.511)	2.290(.090)	0.51(.020)
DHSL-26	26	39.1(1.541)	33.32(1.312)	24.66(0.971)	2.290(.090)	0.51(0.20)
DHSL-15	15	30.8(1.213)	24.99(0.984)	16.33(0.643)	2.290(.090)	0.51(.020)
LEOCO P/N	CIRCUITS	A	B	C	D	E

				leoco LEOCO CORPORATION		APPROVED BY:		PART NO.:				
				GENERAL TOLERANCE		CHECKED BY:		DHSL-**UKL2				
				X° ± 2°		DRAW BY:		TITLE:				
				.X ± 0.30 .012		JUDY 7/14/'95		D-SUB				
				.XX ± 0.20 .008		UNITS		DRAWING NO.:				
				.XXX ± 0.10 .004		mm		DHSL07S				
REV.	ECO. NO.	CHG	APPD.			SCALE		SIZE	SHEET	REV.		
						1:1		A4	1/1	B		