



MBR20...CTG
MBRB20...CTG
MBR20...CTG-1

SCHOTTKY RECTIFIER

20 Amp

$I_{F(AV)} = 20 \text{ Amp}$
 $V_R = 80 \text{ to } 100\text{V}$

Major Ratings and Characteristics





Characteristics	Values	Units
$I_{F(AV)}$ Rectangular waveform (Per Device)	20	A
I_{FRM} @ $T_C = 133^\circ\text{C}$ (Per Leg)	20	A
V_{RRM}	80/90/100	V
I_{FSM} @ $t_p = 5 \mu\text{s}$ sine	850	A
V_F @ 10 Apk, $T_J = 125^\circ\text{C}$	0.70	V
T_J range	-65 to 150	$^\circ\text{C}$

Description/ Features

This center tap Schottky rectifier has been optimized for low reverse leakage at high temperature. The proprietary barrier technology allows for reliable operation up to 150°C junction temperature. Typical applications are in switching power supplies, converters, free-wheeling diodes, and reverse battery protection.

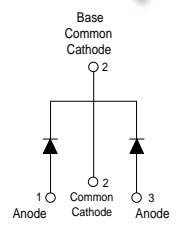
- 150°C T_J operation
- Center tap TO-220, D²Pak and TO-262 packages
- Low forward voltage drop
- High purity, high temperature epoxy encapsulation for enhanced mechanical strength and moisture resistance
- High frequency operation
- Guard ring for enhanced ruggedness and long term reliability

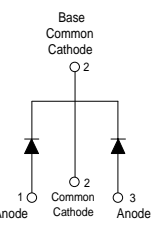
Case Styles

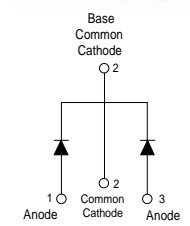
MBR20...CTG	MBRB20...CTG	MBR20...CTG-1
  TO-220	  D²PAK	  TO-262

MBR20...CTG, MBRB20...CTG, MBR20...CTG-1

Preliminary Data Sheet PD-20801 11/04



Voltage Ratings

Parameters	MBR2080CTG MBRB2080CTG MBR2080CTG-1	MBR2090CTG MBRB2090CTG MBR2090CTG-1	MBR20100CTG MBRB20100CTG MBR20100CTG-1
V _R Max. DC Reverse Voltage (V)	80	90	100
V _{RWM} Max. Working Peak Reverse Voltage (V)			

Absolute Maximum Ratings

Parameters	Values	Units	Conditions
I _{F(AV)} Max. Average Forward Current (Per Leg) (Per Device)	10	A	@ T _C = 133°C, (Rated V _R)
	20		
I _{FRM} Peak Repetitive Forward Current (Per Leg)	20	A	Rated V _R , square wave, 20kHz T _C = 133°C
I _{FSM} Non Repetitive Peak Surge Current	850	A	5µs Sine or 3µs Rect. pulse Following any rated load condition and with rated V _{RWM} applied Surge applied at rated load conditions halfwave, single phase, 60Hz
	150		
I _{RSM} Peak Repetitive Reverse Surge Current	0.5	A	2.0 µsec 1.0 KHz
E _{AS} Non-Repetitive Avalanche Energy (Per Leg)	24	mJ	T _J = 25°C, I _{AS} = 2 Amps, L = 12 mH

Electrical Specifications

Parameters	Values	Units	Conditions
V _{FM} Max. Forward Voltage Drop (1)	0.80	V	@ 10A T _J = 25°C
	0.95	V	@ 20A
	0.70	V	@ 10A T _J = 125°C
	0.85	V	@ 20A
I _{RM} Max. Instantaneous Reverse Current (1)	0.10	mA	T _J = 25°C
	6	mA	T _J = 125°C Rated DC voltage
V _{F(TO)} Threshold Voltage	0.433	V	T _J = T _J max.
r _t Forward Slope Resistance	15.8	mΩ	
C _T Max. Junction Capacitance	400	pF	V _R = 5V _{DC} (test signal range 100Khz to 1Mhz) 25°C
L _S Typical Series Inductance	8.0	nH	Measured from top of terminal to mounting plane
dv/dt Max. Voltage Rate of Change	10000	V/µs	(Rated V _R)

(1) Pulse Width < 300µs, Duty Cycle <2%

Thermal-Mechanical Specifications

Parameters	Values	Units	Conditions
T _J Max. Junction Temperature Range	-65 to 150	°C	
T _{stg} Max. Storage Temperature Range	-65 to 175	°C	
R _{thJC} Max. Thermal Resistance Junction to Case (Per Leg)	2.0	°C/W	DC operation
R _{thCS} Typical Thermal Resistance Case to Heatsink	0.50	°C/W	Mounting surface, smooth and greased Only for TO-220
R _{thJA} Max. Thermal Resistance Junction to Ambient	50	°C/W	DC operation For D ² Pak and TO-262
wt Approximate Weight	2 (0.07)	g (oz.)	
T Mounting Torque	Min. 6 (5)	Kg-cm (lbf-in)	Non-lubricated threads
	Max. 12 (10)		
Device Marking	MBR20...CTG	Case style TO-220	
	MBRB20...CG	Case style D ² -Pak	
	MBR20...CG-1	Case style TO-262	

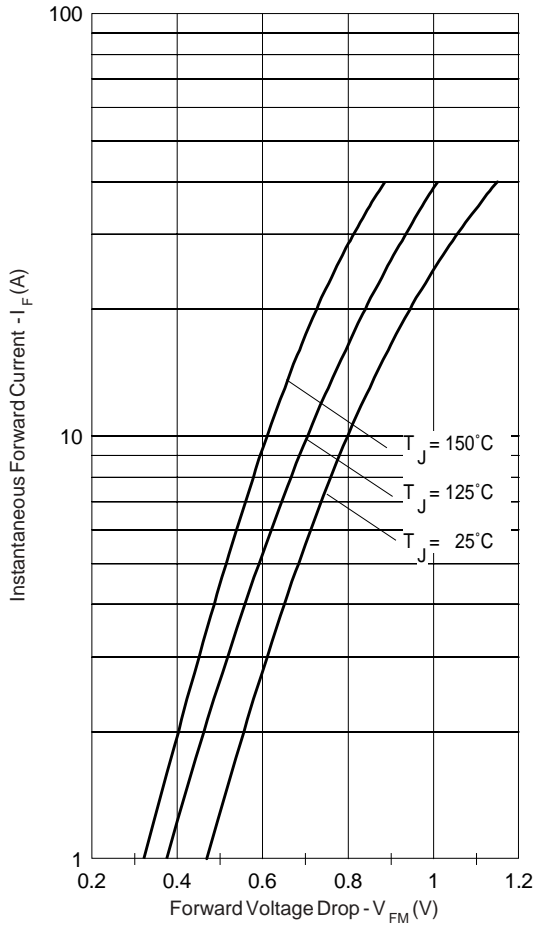

Fig. 1 - Max. Forward Voltage Drop Characteristics (Per Leg)

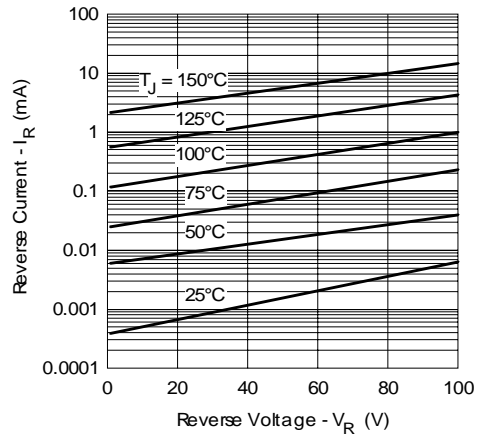

Fig. 2 - Typical Values Of Reverse Current Vs. Reverse Voltage (Per Leg)

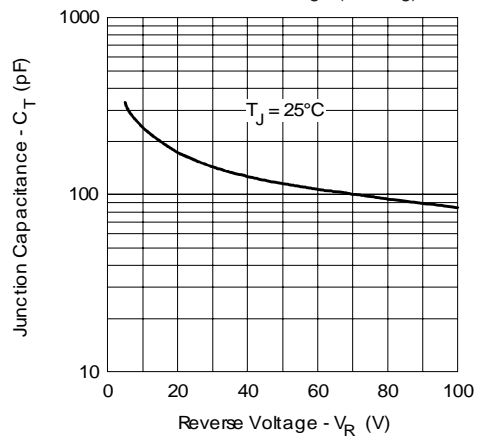

Fig. 3 - Typical Junction Capacitance Vs. Reverse Voltage (Per Leg)

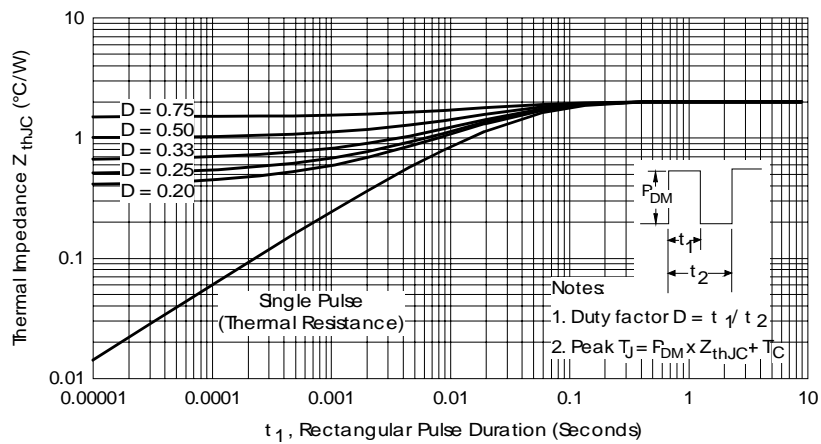

Fig. 4 - Max. Thermal Impedance Z_{thJC} Characteristics (Per Leg)

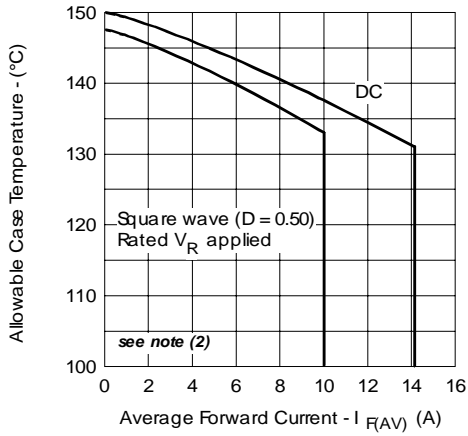

Fig. 5 - Max. Allowable Case Temperature Vs. Average Forward Current (Per Leg)

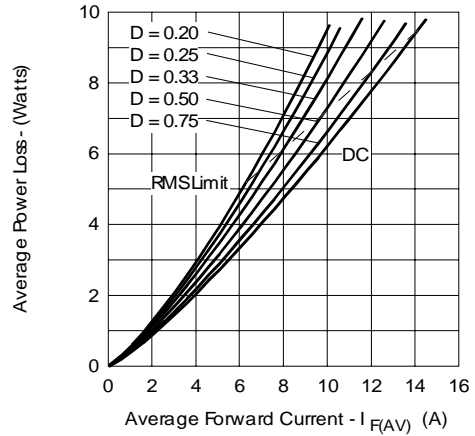

Fig. 6 - Forward Power Loss Characteristics (Per Leg)

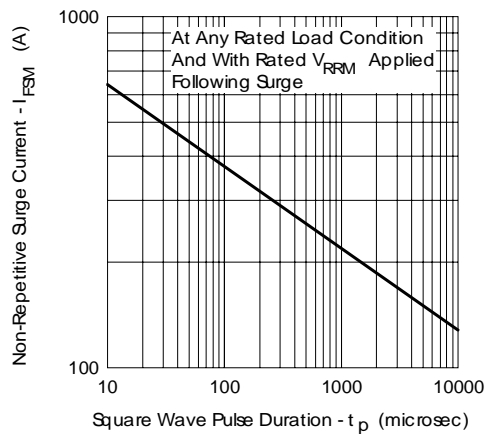
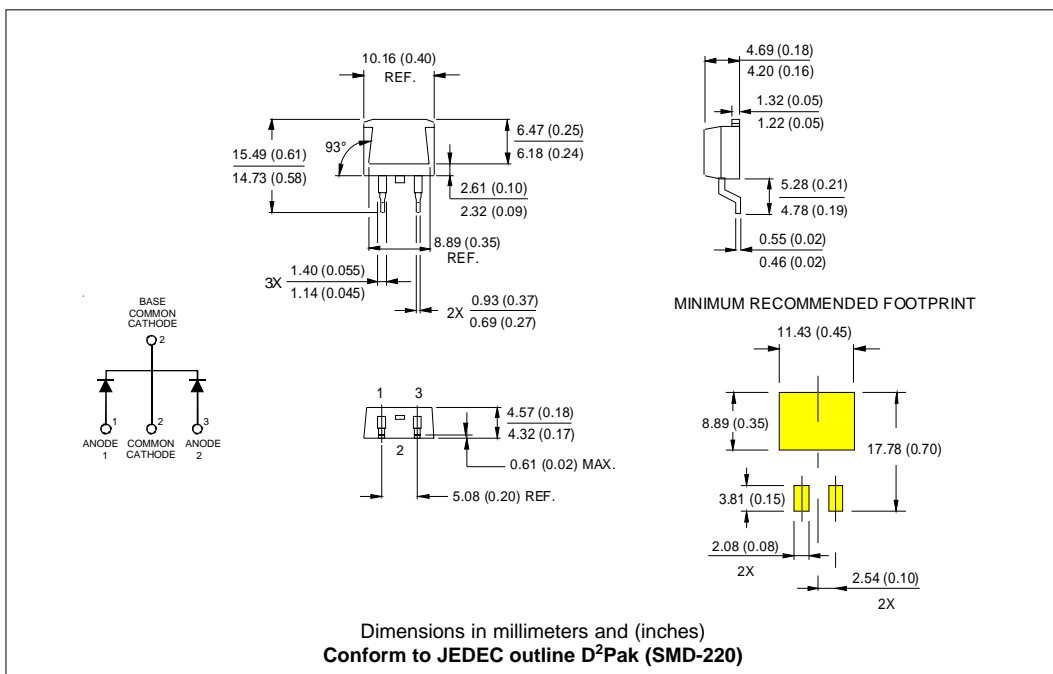
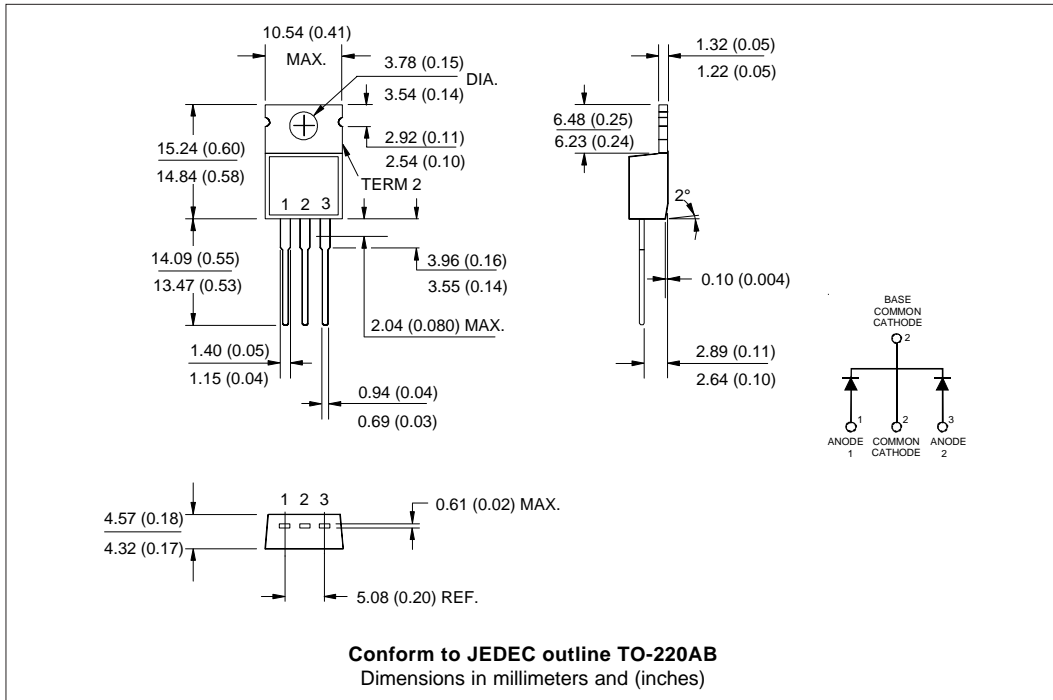

Fig. 7 - Max. Non-Repetitive Surge Current (Per Leg)

- (2) Formula used: $T_C = T_J - (P_d + P_{d_{REV}}) \times R_{thJC}$;
 $P_d = \text{Forward Power Loss} = I_{F(AV)} \times V_{FM} @ (I_{F(AV)} / D)$ (see Fig. 6);
 $P_{d_{REV}} = \text{Inverse Power Loss} = V_{R1} \times I_R (1 - D)$; $I_R @ V_{R1} = \text{rated } V_R$

Outline Table



MBR20...CTG, MBRB20...CTG, MBR20...CTG-1

Preliminary Data Sheet PD-20801 11/04

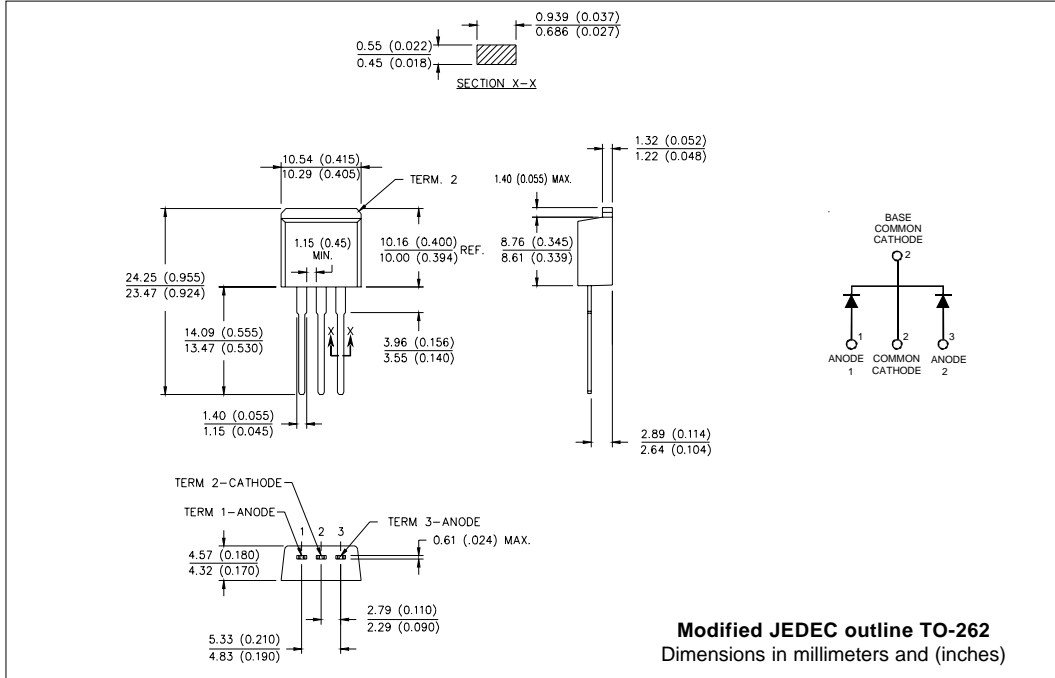

Tape & Reel Information

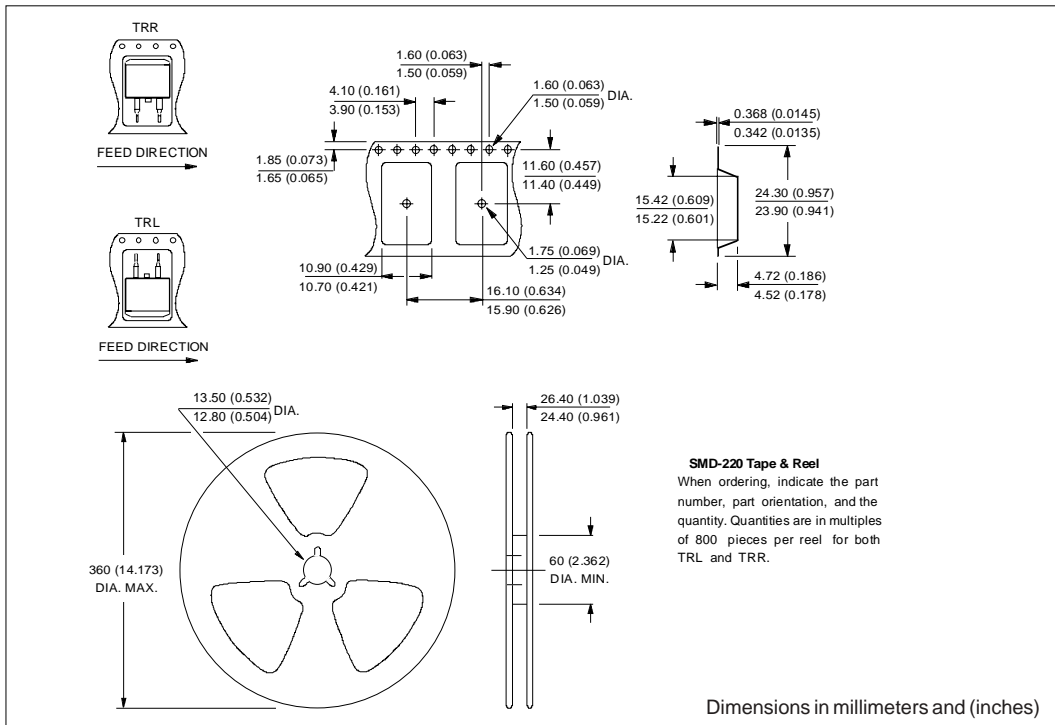

Part Marking Information

EXAMPLE: THIS IS A MBR20100CTG
 LOT CODE 1789
 ASSEMBLED ON WW 19, 2000
 IN THE ASSEMBLY LINE "C"

TO-220

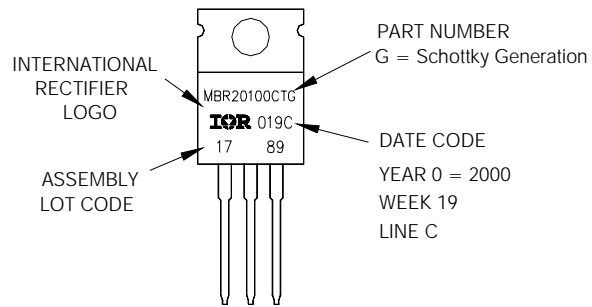

EXAMPLE: THIS IS A MBRB20100CTG
 LOT CODE 8024
 ASSEMBLED ON WW 02, 2000
 IN THE ASSEMBLY LINE "L"

D²PAK

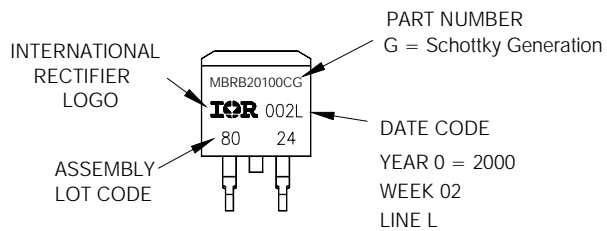

EXAMPLE: THIS IS A MBR20100CTG-1
 LOT CODE 1789
 ASSEMBLED ON WW 19, 1999
 IN THE ASSEMBLY LINE "C"

TO-262

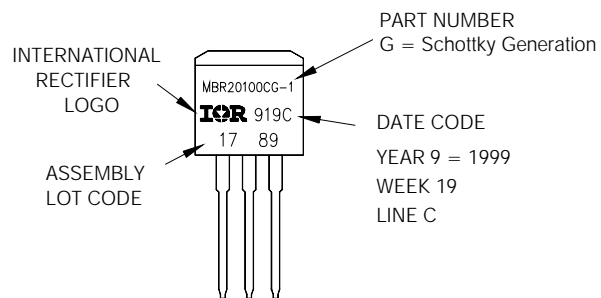

Ordering Information Table

Device Code								
1	2	3	4	5	6	7	8	
	MBR	B	20	100	CT	G	-1	TRL

1	-	Essential Part Number
2	-	B = Surface Mount None = TO-220
3	-	Current Rating (20 = 20A)
4	-	Voltage code: Code = V_{RRM}
5	-	CT = Essential Part Number
6	-	G = Schottky Generation
7	-	"-1" = TO-262
8	-	<ul style="list-style-type: none"> • none = Tube (50 pieces) • TRL = Tape & Reel (Left Oriented - for D²Pak only) • TRR = Tape & Reel (Right Oriented - for D²Pak only)

080 = 80V
 090 = 90V
 100 = 100V

Data and specifications subject to change without notice.
 This product has been designed and qualified for Industrial Level.
 Qualification Standards can be found on IR's Web site.