

PIN HEADER WITH LATCHING MECHANISM

TX3-LT: Right Angle through hole type

Standard Latch Type

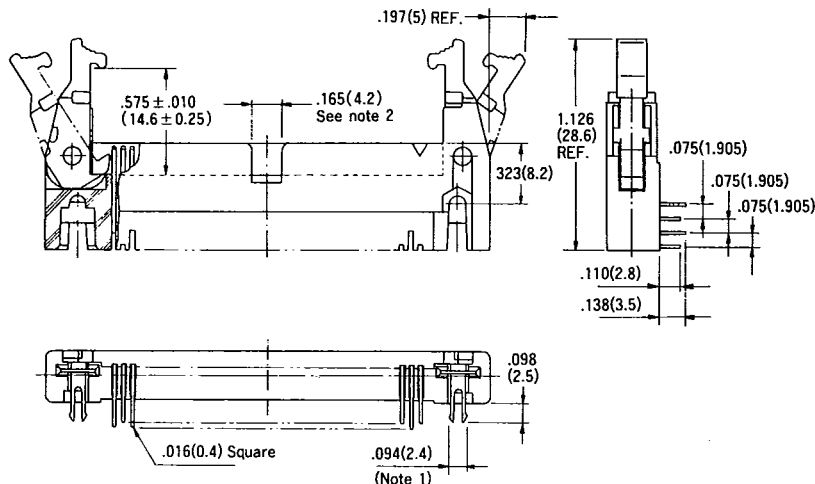
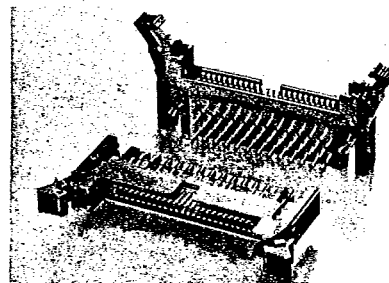
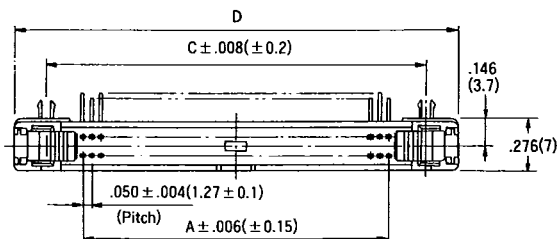

Short Latch Type

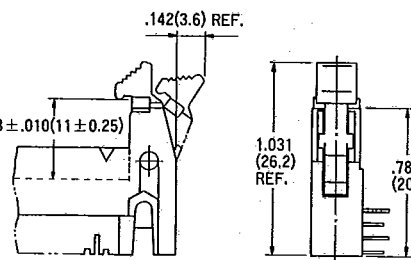

(Note) For short latch type, do not use strain relief on mating, IDC socket connector.

(Note 1) Above figure shows the connector with expansion post. Without-expansion-post type is also available.

(Note 2) For 80 and 100 position connector, two polarizing keyways are provided. For the other contact arrangement one polarizing keyway is provided at the center.

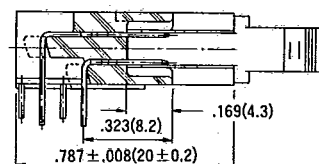

HOW TO ORDER

TX3-40P-D2LT-LH1

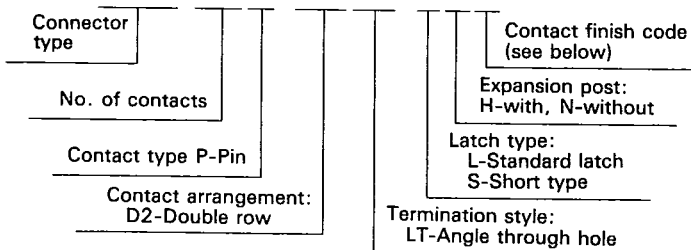

■ P.C. board hole diameter.....See page 9

No. of Contact	Part Number (See note 1)				Inches			Millimeters		
	Standard latch type		Short latch type		A	C	D	A	C	D
	With expansion post	Without expansion post	With expansion post	Without expansion post			±.016			±0.4
20	TX3-20P-D2LT-LH*	TX3-20P-D2LT-LN*	TX3-20P-D2LT-SH*	TX3-20P-D2LT-SN*	.450	.850	1.197	11.43	21.59	30.4
26	TX3-26P-D2LT-LH*	TX3-26P-D2LT-LN*	TX3-26P-D2LT-SH*	TX3-26P-D2LT-SN*	.600	1.000	1.346	15.24	25.40	34.2
30	TX3-30P-D2LT-LH*	TX3-30P-D2LT-LN*	TX3-30P-D2LT-SH*	TX3-30P-D2LT-SN*	.700	1.100	1.449	17.78	27.94	36.8
34	TX3-34P-D2LT-LH*	TX3-34P-D2LT-LN*	TX3-34P-D2LT-SH*	TX3-34P-D2LT-SN*	.800	1.200	1.547	20.32	30.48	39.3
40	TX3-40P-D2LT-LH*	TX3-40P-D2LT-LN*	TX3-40P-D2LT-SH*	TX3-40P-D2LT-SN*	.950	1.350	1.697	24.13	34.29	43.1
50	TX3-50P-D2LT-LH*	TX3-50P-D2LT-LN*	TX3-50P-D2LT-SH*	TX3-50P-D2LT-SN*	1.200	1.600	1.949	30.48	40.64	49.5
60	TX3-60P-D2LT-LH*	TX3-60P-D2LT-LN*	TX3-60P-D2LT-SH*	TX3-60P-D2LT-SN*	1.450	1.850	2.197	36.83	46.99	55.8
68	TX3-68P-D2LT-LH*	TX3-68P-D2LT-LN*	TX3-68P-D2LT-SH*	TX3-68P-D2LT-SN*	1.650	2.050	2.398	41.91	52.07	60.9
80	TX3-80P-D2LT-LH*	TX3-80P-D2LT-LN*	TX3-80P-D2LT-SH*	TX3-80P-D2LT-SN*	1.950	2.350	2.697	49.53	59.69	68.5
100	TX3-100P-D2LT-LH*	TX3-100P-D2LT-LN*	TX3-100P-D2LT-SH*	TX3-100P-D2LT-SN*	2.450	2.850	3.197	62.23	72.39	81.2

(Note 1) * Add finish code (Selective gold plating thickness on contact area)
 1... .000004 inch (0.1µm) min. 2... .000012 inch (0.3µm) min. 3... .000030 inch (0.76µm) min.

Dimensions subject to change.
 (millimeters are in parenthesis)

BOARD TO CABLE CONNECTIONS IDC SOCKET (TX1/TX2) & PIN HEADER WITH LATCH (TX3)

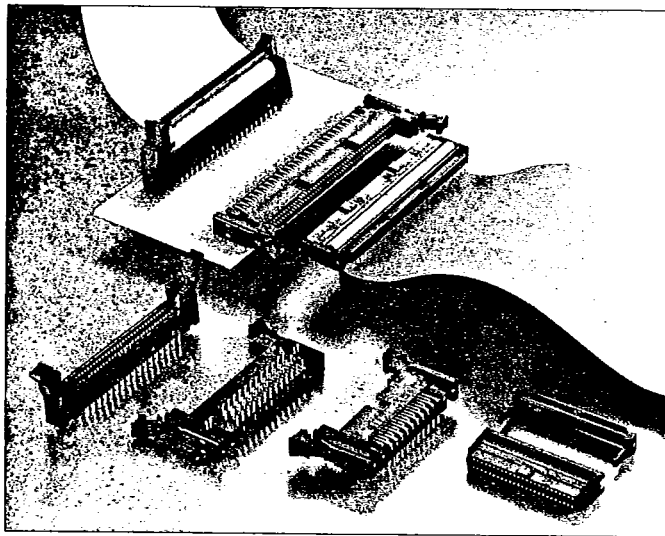

The TX series of connectors will help you to further take advantage of high density packaging in your interior circuit boards.

● **TWO VERSIONS OF IDC SOCKETS**

TX1 for ribbon cable on .025inch (0.635mm) centers.

TX2 for ribbon cable on .050inch (1.27mm) centers.

TX1 version can be terminated Daisy-chain style in the middle of the cable.

TX2 version can be terminated to two stacked .050inch (1.27mm) pitch cables using specific termination tools. Applies to cable end termination only.

● Socket contacts are tuning fork style insuring dual wipe contact patches. The insulation displacement blades are angled to achieve the highest density IDC package available.

■ **STANDARD DATA**

No. of contacts	20, 26, 30, 34, 40, 50, 60, 68, 80, 100
Current rating	0.5A
Dielectric withstanding voltage	500VAC r.m.s.
Insulation resistance	100 megohms min.
Contact resistance	25 milliohms max.
Applicable PCB	.063 inch (1.6mm) thick
Applicable F.R.C	.025 inch (0.635mm) pitch... # 30AWG .050 inch (1.27mm) pitch... # 28AWG
Mating side pattern	.050×.100 inch (1.27×2.54mm) dual row, in-line
PCB mounting side pattern	.050×.075 inch (1.27×1.905mm) staggered four row

■ **MATERIALS & FINISHES**

IDC SOCKET

Components	Materials	Finishes
Insulators	PBT (UL94V-O)	Black
Strain relief	Nylon 66	Black
Cover	Glass-filled Nylon (UL94V-O)	Black
Contacts	Phosphor bronze	Connecting area: Gold over nickel IDC/terminal area: Tin over plating Others: Gold flash over nickel

PIN HEADER

Insulator	PBT (UL94V-O)	Black
Expansion post	Phosphor bronze	Tin plate
Latch	Nylon (UL94V-O)	Black
Contacts	Phosphor bronze	Connecting area: Gold over nickel Terminal area: Tin over plating

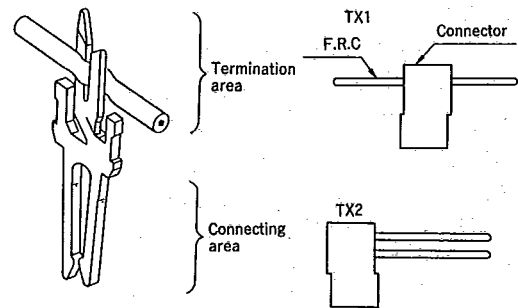

● **PIN HEADER-TX3**

The circuit board headers may be ordered in straight mount or right angle styles. The option of standard or short latches is available. JAE's expansion post for pre-solder fastening is an added option. See ordering information.

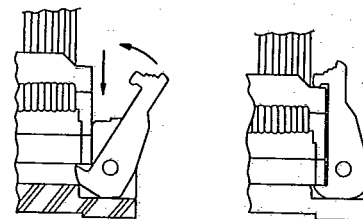

● The TX3 header utilizes self-latching, self-ejecting latches to insure smooth operation when mating and unmating.

IDC MACHINE

Bench top pneumatic, semi-automatic, IDC termination machine and hand IDC termination machine are available for termination of TX1 & TX2 connectors. Termination applicator is interchangeable between these machines. So you can terminate both TX1 (.025inch/0.635mm pitch) and TX2 (.050inch/1.27mm) with one machine by interchanging applicator in IDC area.

For details of IDC machines and termination procedure, please refer to the operations manual.

IDC machine (only)

Operations manual No. T704000B

Applicator and procedure

Operations manual No. T704034

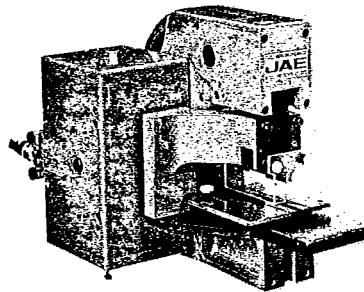

Pneumatic semi-automatic IDC Tool

Hand IDC Tool

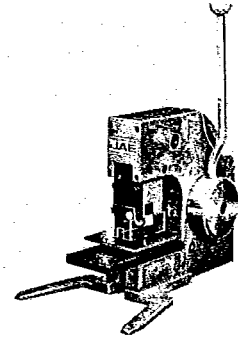

Applicable Connector	IDC Machine Part Number (See note 1)		Applicator (See note 2)	Interchangeable unit (See note 3)
	Pneumatic, semi-automatic type	Hand type		
TX1	SP399-1-TX1	SP299-1-TX1	MT499-TX1-1	700-04034-200
TX2	SP399-1-TX2	SP299-1-TX2	MT499-TX2-1	700-04035-200

(Note 1) With interchangeable applicator.

(Note 2) When Purchasing interchangeable applicator individually (Including interchangeable unit)

(Note 3) When purchasing interchangeable unit alone (Base plate and pressure unit)

PCB MOUNTING HOLE DIMENSION (for pin header with latching mechanism)

STRAIGHT PIN HEADER

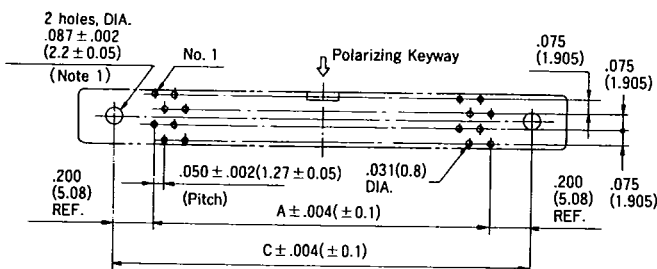

(Note 1) Omit when ordered without expansion posts.

(Ref. only) Contact location of 50 contacts

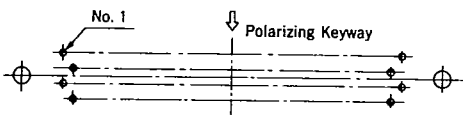

No. of Contact	A ± .004 (0.1)	C ± .004 (0.1)
20	.450 (11.43)	.850 (21.59)
26	.600 (15.24)	1.000 (25.40)
30	.700 (17.78)	1.100 (27.94)
34	.800 (20.32)	1.200 (30.48)
40	.950 (24.13)	1.350 (34.29)
50	1.200 (30.48)	1.600 (40.64)
60	1.450 (36.83)	1.850 (46.99)
68	1.650 (41.91)	2.050 (52.07)
80	1.950 (49.53)	2.350 (59.69)
100	2.450 (62.23)	2.850 (72.39)

RIGHT ANGLE PIN HEADER

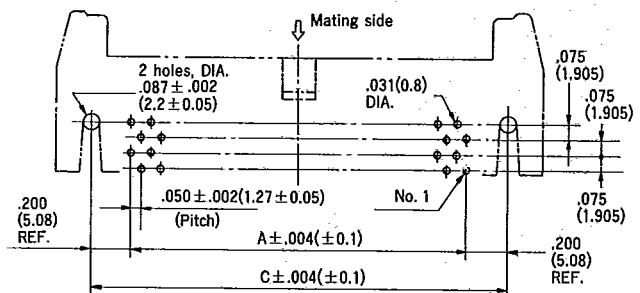

Without expansion post: .087inch/2.2mm dia. (M2 screw is applicable)

(Ref. only) Contact location of 50 contacts

