

Features

- High-speed: 10, 12, 15 ns
- Fully static operation
- All inputs and outputs directly TTL compatible
- Three state outputs
- Low data retention current ($V_{CC} = 2V$)
- Single $3.3V \pm 0.3$ Power Supply
- Low CMOS Standby current of 5 mA max

■ Packages

- 32-pin TSOP
- 32-pin 300 mil SOJ

Description

The V61C3181024 is a 1,048,576-bit static random-access memory organized as 131,072 words by 8 bits. Inputs and three-state outputs are TTL compatible and allow for direct interfacing with common system bus structures. The V61C3181024 is available in 32-pin SOJ and TSOP.

Functional Block Diagram

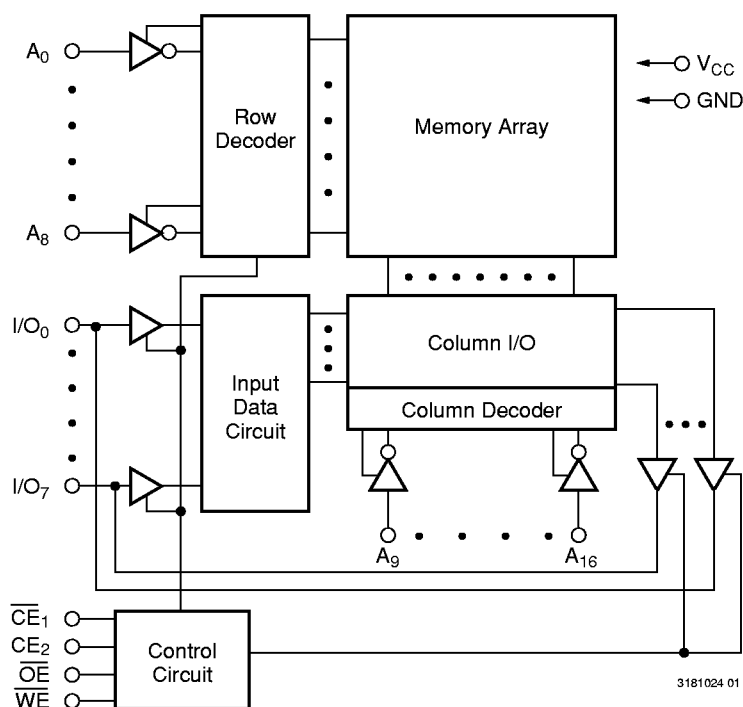

Device Usage Chart

Operating Temperature Range	Package Outline		Access Time (ns)			Temperature Mark
	T	R	10	12	15	
0°C to 70°C	Blank

Pin Descriptions

A₀-A₁₆ Address Inputs

These 17 address inputs select one of the 128K x 8 bit segments in the RAM.

\overline{CE}_1 , CE₂ Chip Enable Inputs

\overline{CE}_1 is active LOW and CE₂ is active HIGH. Both chip enables must be active to read from or write to the device. If either chip enable is not active, the device is deselected and is in a standby power mode. The I/O pins will be in the high-impedance state when deselected.

\overline{OE} Output Enable Input

The Output Enable input is active LOW. When \overline{OE} is LOW with \overline{CE} LOW and \overline{WE} HIGH, data of the selected memory location will be available on the I/O pins. When \overline{OE} is HIGH, the I/O pins will be in the high impedance state.

\overline{WE} Write Enable Input

An active LOW input, \overline{WE} input controls read and write operations. When \overline{CE} and \overline{WE} inputs are both LOW, the data present on the I/O pins will be written into the selected memory location.

I/O₀-I/O₇ Data Input and Data Output Ports

These 8 bidirectional ports are used to read data from and write data into the RAM.

V_{CC} Power Supply

GND Ground

Pin Configurations (Top View)

32-Pin SOJ

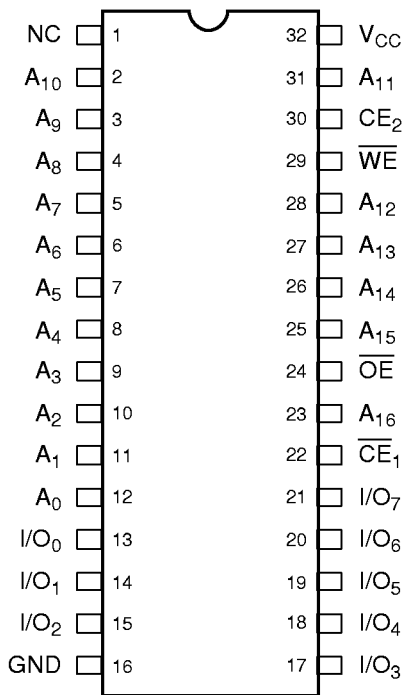

3181024 02

32-Pin TSOP-I

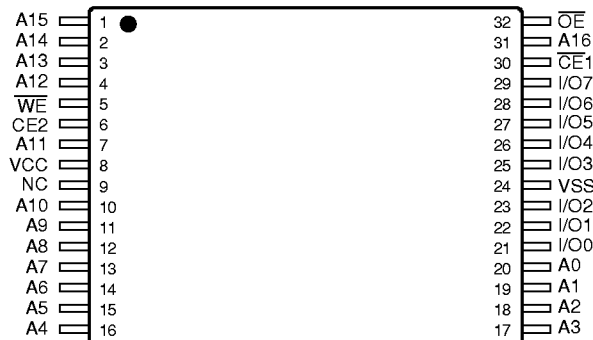

3181024 03

Part Number Information

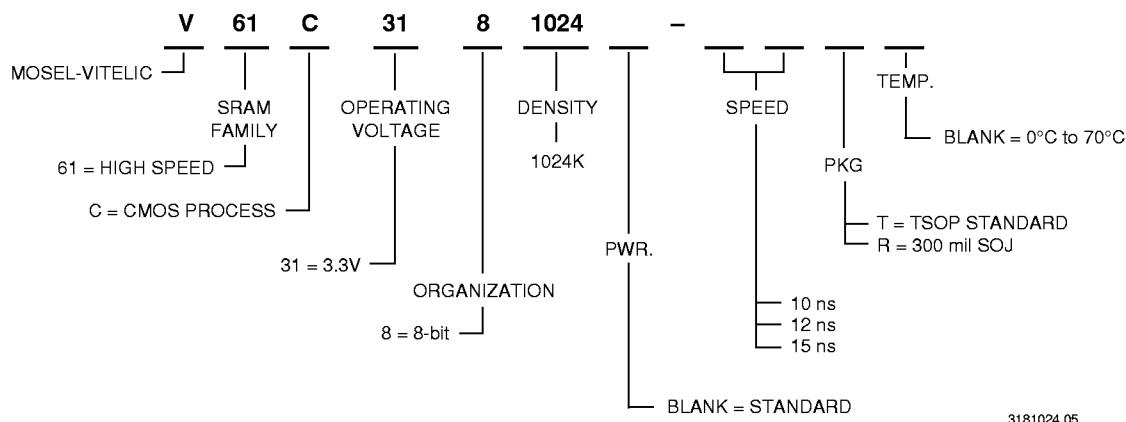

3181024 05

Absolute Maximum Ratings (1)

Symbol	Parameter	Commercial	Units
V _N	Input Voltage	-0.5 to V _{CC} + 0.5	V
V _{DQ}	Input/Output Voltage Applied	V _{CC} + 0.5	V
T _{BIAS}	Temperature Under Bias	-10 to +125	°C
T _{STG}	Storage Temperature	-65 to +150	°C

NOTE:

- Stresses greater than those listed under "Absolute Maximum Ratings" may cause permanent damage to the device. This is a stress rating only and functional operation of the device at these or any other conditions above those indicated in the operational sections of this specification is not implied. Exposure to absolute maximum rating conditions for extended periods may affect reliability.

Capacitance*

T_A = 25°C, f = 1.0MHz

Symbol	Parameter	Conditions	Max.	Unit
C _{IN}	Input Capacitance	V _{IN} = 0V	6	pF
C _{OUT}	Output Capacitance	V _{I/O} = 0V	8	pF

NOTE:

- This parameter is guaranteed by design and not tested.

Truth Table

Mode	\overline{CE}_1	CE_2	\overline{OE}	\overline{WE}	I/O Operation
Standby	H	X	X	X	High Z
Standby	X	L	X	X	High Z
Output Disable	L	H	H	H	High Z
Read	L	H	L	H	D _{OUT}
Write	L	H	X	L	D _{IN}

NOTE:

X = Don't Care, L = LOW, H = HIGH

DC Electrical Characteristics (over all temperature ranges, $V_{CC} = 3.3V \pm 0.3$)

Symbol	Parameter	Test Conditions	Min.	Typ.	Max.	Units
V_{IL}	Input LOW Voltage ^(1,2)		-0.5	—	0.8	V
V_{IH}	Input HIGH Voltage ⁽¹⁾		2.2	—	$V_{CC} + 0.3$	V
I_{IL}	Input Leakage Current	$V_{CC} = \text{Max}, V_{IN} = 0V \text{ to } V_{CC}$	-5	—	5	μA
I_{OL}	Output Leakage Current	$V_{CC} = \text{Max}, \overline{CE}_1 = V_{IH}, V_{OUT} = 0V \text{ to } V_{CC}$	-5	—	5	μA
V_{OL}	Output LOW Voltage	$I_{OL} = 4\text{mA}$	—	—	0.4	V
V_{OH}	Output HIGH Voltage	$I_{OH} = -2\text{mA}$	2.4	—	—	V

Symbol	Parameter	Com. ⁽⁴⁾	Units
I_{CC1}	Average Operating Current, $\overline{CE}_1 = V_{IL}, CE_2 = V_{IH}$, Output Open, $V_{CC} = \text{Max}, f = f_{MAX}$ ⁽³⁾	100	mA
I_{SB}	TTL Standby Current $\overline{CE}_1 \geq V_{IH}, CE_2 \leq V_{IL}, V_{CC} = \text{Max}.$	25	mA
I_{SB1}	CMOS Standby Current, $\overline{CE}_1 \geq V_{CC} - 0.2V, CE_2 \leq 0.2V,$ $V_{IN} \geq V_{CC} - 0.2V \text{ or } V_{IN} \leq 0.2V, V_{CC} = \text{Max}.$	2	mA

NOTES:

1. These are absolute values with respect to device ground and all overshoots due to system or tester noise are included.
2. V_{IL} (Min.) = -3.0V for pulse width < 20ns.
3. $f_{MAX} = 1/t_{RC}$.
4. Maximum values.

AC Test Conditions

Input Pulse Levels	0 to 3V
Input Rise and Fall Times	3 ns
Timing Reference Levels	1.5V
Output Load	see below

AC Test Loads and Waveforms

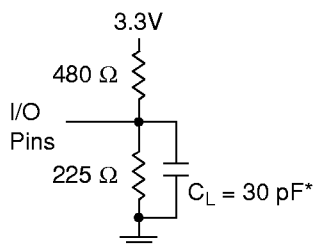

* Includes scope and jig capacitance

3181024 06

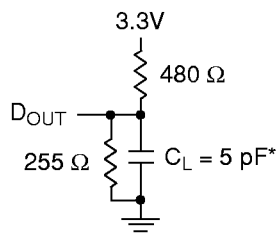

for $t_{CLZ}, t_{CHZ}, t_{OLZ}, t_{WZ}, t_{OW},$ and t_{OHZ}

3181024 06B

Key to Switching Waveforms

WAVEFORM	INPUTS	OUTPUTS
	MUST BE STEADY	WILL BE STEADY
	MAY CHANGE FROM H TO L	WILL BE CHANGING FROM H TO L
	MAY CHANGE FROM L TO H	WILL BE CHANGING FROM L TO H
	DON'T CARE: ANY CHANGE PERMITTED	CHANGING: STATE UNKNOWN
	DOES NOT APPLY	CENTER LINE IS HIGH IMPEDANCE "OFF" STATE

Data Retention Characteristics

Symbol	Parameter	Min.	Typ. ⁽²⁾	Max.	Units
V _{DR}	V _{CC} for Data Retention $\overline{CE}_1 \geq V_{CC} - 0.2V, CE_2 \leq 0.2V,$ $V_{IN} \geq V_{CC} - 0.2V, \text{ or } V_{IN} \leq 0.2V$	2.0	—	5.5	V
I _{CCDR}	Data Retention Current $\overline{CE}_1 \geq V_{DR} - 0.2V, CE_2 \leq 0.2V,$ $V_{IN} \geq V_{CC} - 0.2V, \text{ or } V_{IN} \leq 0.2V$	—	75	150	μA
t _{CDR}	Chip Deselect to Data Retention Time	0	—	—	ns
t _R	Operation Recovery Time (see Retention Waveform)	t _{RC} ⁽¹⁾	—	—	ns

NOTES:

- t_{RC} = Read Cycle Time
- T_A = +25°C.

Low V_{CC} Data Retention Waveform (1) (\overline{CE}_1 Controlled)

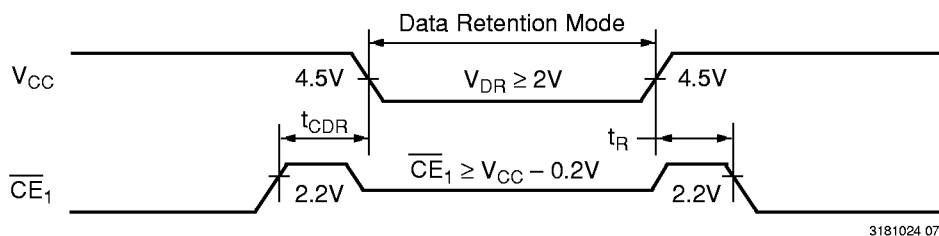

Low V_{CC} Data Retention Waveform (2) (CE₂ Controlled)

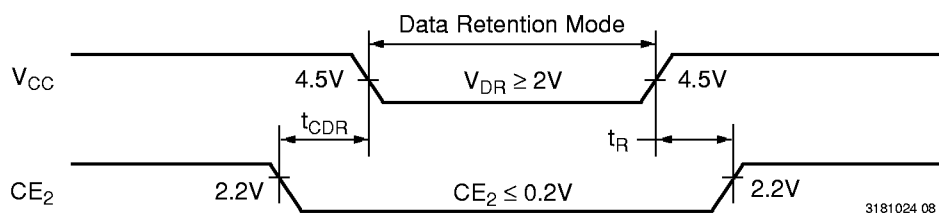

AC Electrical Characteristics

(over all temperature ranges)

Read Cycle

Parameter Name	Parameter	-10		-12		-15		Unit
		Min.	Max.	Min.	Max.	Min.	Max.	
t_{RC}	Read Cycle Time	10	—	12	—	15	—	ns
t_{AA}	Address Access Time	—	10	—	12	—	15	ns
t_{ACS1}	Chip Enable Access Time	—	10	—	12	—	15	ns
t_{ACS2}	Chip Enable Access Time	—	10	—	12	—	15	ns
t_{OE}	Output Enable to Output Valid	—	6	—	6	—	7	ns
t_{CLZ1}	Chip Enable to Output in Low Z	3	—	3	—	3	—	ns
t_{CLZ2}	Chip Enable to Output in Low Z	3	—	3	—	3	—	ns
t_{OLZ}	Output Enable to Output in Low Z	0	—	0	—	0	—	ns
t_{CHZ}	Chip Disable to Output in High Z	0	3	0	3	0	4	ns
t_{OHZ}	Output Disable to Output in High Z	0	3	0	3	0	4	ns
t_{OH}	Output Hold from Address Change	3	—	3	—	3	—	ns

Write Cycle

Parameter Name	Parameter	-10		-12		-15		Unit
		Min.	Max.	Min.	Max.	Min.	Max.	
t_{WC}	Write Cycle Time	10	—	12	—	15	—	ns
t_{CW1}	Chip Enable to End of Write	8	—	10	—	13	—	ns
t_{CW2}	Chip Enable to End of Write	8	—	10	—	13	—	ns
t_{AS}	Address Setup Time	0	—	0	—	0	—	ns
t_{AW}	Address Valid to End of Write	8	—	10	—	13	—	ns
t_{WP}	Write Pulse Width	8	—	9	—	11	—	ns
t_{AH}	Address Hold to End of Write	0	—	0	—	0	—	ns
t_{WHZ}	Write to Output High-Z	0	5	0	5	0	5	ns
t_{WLZ}	Write to Output Low Z	3	—	3	—	5	—	ns
t_{DW}	Data Setup to End of Write	5	—	6	—	8	—	ns
t_{DH}	Data Hold from End of Write	0	—	0	—	0	—	ns

Switching Waveforms (Read Cycle)

Read Cycle 1^(1, 2)

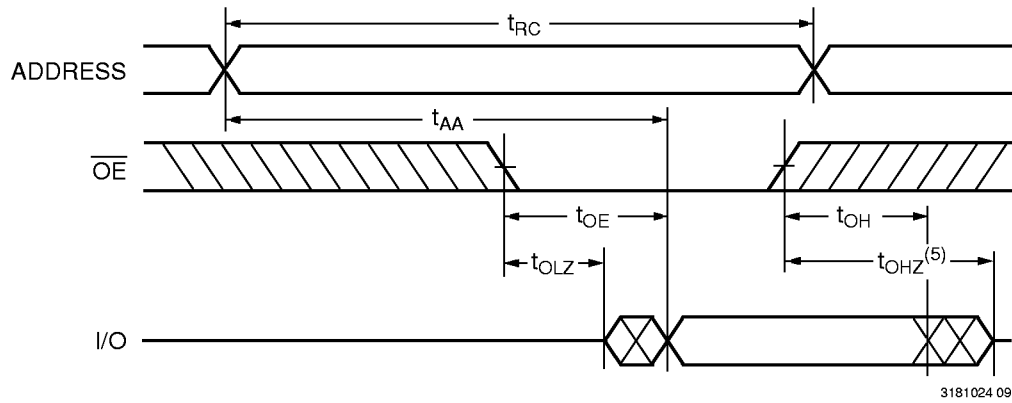

Read Cycle 2^(1, 2, 4)

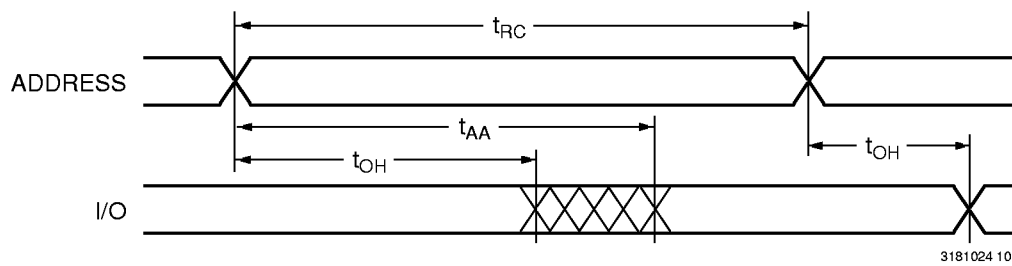

Read Cycle 3^(1, 3, 4)

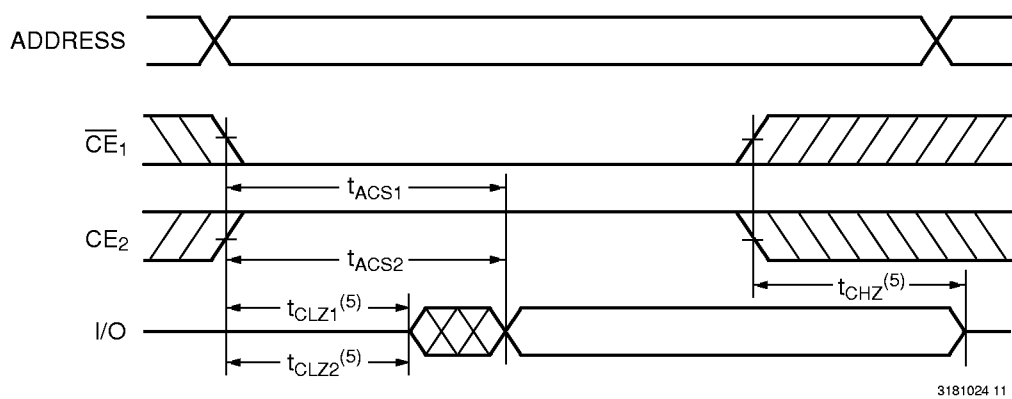

NOTES:

1. $\overline{WE} = V_{IH}$.
2. $\overline{CE}_1 = V_{IL}$ and $CE_2 = V_{IH}$.
3. Address valid prior to or coincident with \overline{CE}_1 transition LOW and/or CE_2 transition HIGH.
4. $\overline{OE} = V_{IL}$.
5. Transition is measured $\pm 500mV$ from steady state with $C_L = 5pF$. This parameter is guaranteed and not 100% tested.

Switching Waveforms (Write Cycle)

Write Cycle 1 (\overline{WE} Controlled)⁽⁴⁾

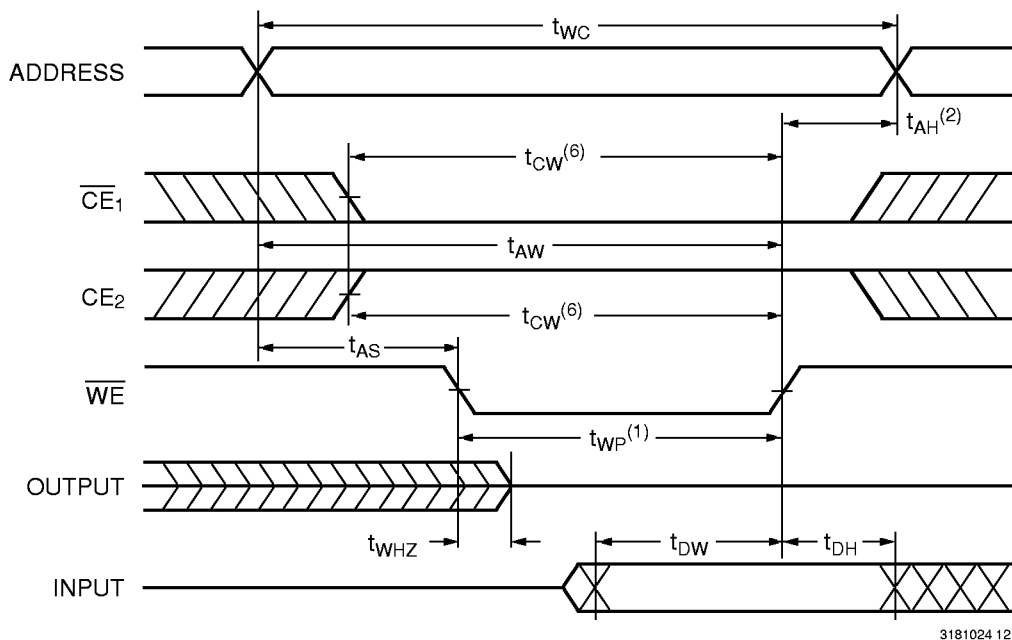

3181024 12

Write Cycle 2 (CE Controlled)⁽⁴⁾

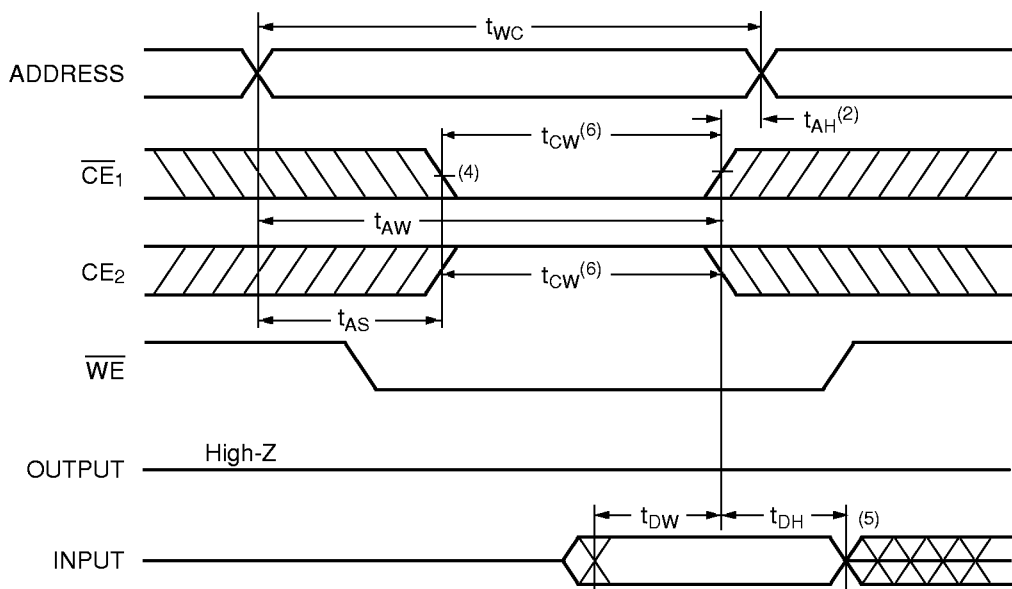

3181024 13

NOTES:

1. The internal write time of the memory is defined by the overlap of \overline{CE}_1 and CE_2 active and \overline{WE} low. All signals must be active to initiate and any one signal can terminate a write by going inactive. The data input setup and hold timing should be referenced to the second transition edge of the signal that terminates the write.
2. t_{AH} is measured from the earlier of \overline{CE}_1 or \overline{WE} going high, or CE_2 going LOW at the end of the write cycle.
3. During this period, I/O pins are in the output state so that the input signals of opposite phase to the outputs must not be applied.
4. $\overline{OE} = V_{IL}$ or V_{IH} . However it is recommended to keep \overline{OE} at V_{IH} during write cycle to avoid bus contention.
5. If \overline{CE}_1 is LOW and CE_2 is HIGH during this period, I/O pins are in the output state. Then the data input signals of opposite phase to the outputs must not be applied to them.
6. t_{CW} is measured from \overline{CE}_1 going low or CE_2 going HIGH to the end of write.

Package Diagrams

32-Pin 300 mil SOJ

Units in inches

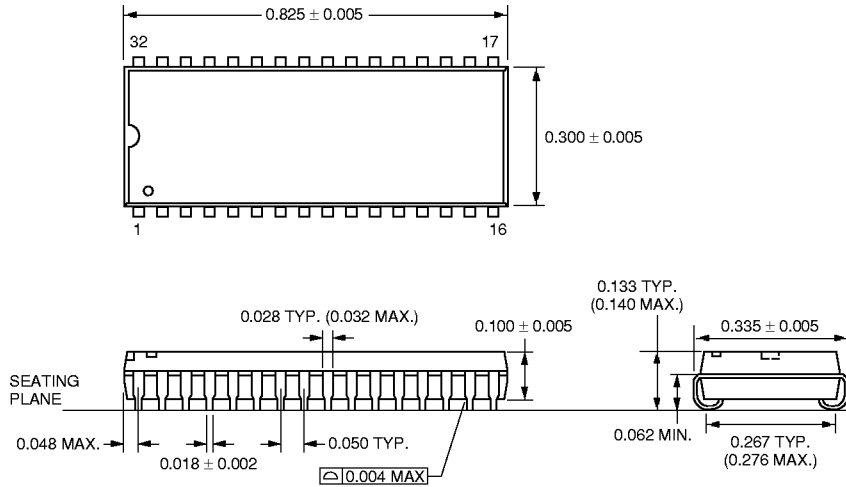

32-Pin TSOP-I

Units in inches [mm]

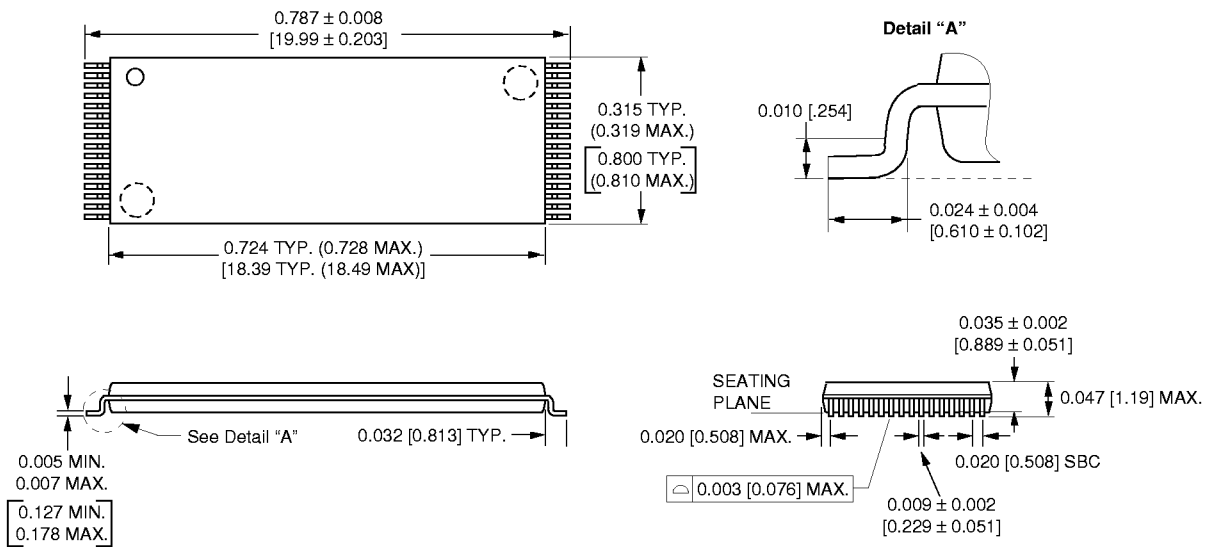

U.S.A.

3910 NORTH FIRST STREET
SAN JOSE, CA 95134
PHONE: 408-433-6000
FAX: 408-433-0952

HONG KONG

19 DAI FU STREET
TAIPO INDUSTRIAL ESTATE
TAIPO, NT, HONG KONG
PHONE: 852-2665-4883
FAX: 852-2664-7535

TAIWAN

7F, NO. 102
MIN-CHUAN E. ROAD, SEC. 3
TAIPEI
PHONE: 886-2-2545-1213
FAX: 886-2-2545-1209

1 CREATION ROAD I
SCIENCE BASED IND. PARK
HSIN CHU, TAIWAN, R.O.C.
PHONE: 886-3-578-3344
FAX: 886-3-579-2838

SINGAPORE

10 ANSON ROAD #23-13
INTERNATIONAL PLAZA
SINGAPORE 079903
PHONE: 65-3231801
FAX: 65-3237013

JAPAN

WBG MARINE WEST 25F
6, NAKASE 2-CHOME
MIHAMA-KU, CHIBA-SHI
CHIBA 261-71
PHONE: 81-43-299-6000
FAX: 81-43-299-6555

IRELAND & UK

BLOCK A UNIT 2
BROOMFIELD BUSINESS PARK
MALAHIDE
CO. DUBLIN, IRELAND
PHONE: +353 1 8038020
FAX: +353 1 8038049

**GERMANY
(CONTINENTAL
EUROPE & ISRAEL)**

71083 HERRENBERG
BENZSTR. 32
GERMANY
PHONE: +49 7032 2796-0
FAX: +49 7032 2796 22

U.S. SALES OFFICES**NORTHWESTERN**

3910 NORTH FIRST STREET
SAN JOSE, CA 95134
PHONE: 408-433-6000
FAX: 408-433-0952

NORTHEASTERN

SUITE 436
20 TRAFALGAR SQUARE
NASHUA, NH 03063
PHONE: 603-889-4393
FAX: 603-889-9347

NORTHEASTERN

SUITE 436
20 TRAFALGAR SQUARE
NASHUA, NH 03063
PHONE: 603-889-4393
FAX: 603-889-9347

SOUTHWESTERN

SUITE 200
5150 E. PACIFIC COAST HWY.
LONG BEACH, CA 90804
PHONE: 562-498-3314
FAX: 562-597-2174

**CENTRAL &
SOUTHEASTERN**

604 FIELDWOOD CIRCLE
RICHARDSON, TX 75081
PHONE: 972-690-1402
FAX: 972-690-0341

The information in this document is subject to change without notice.

MOSEL VITELIC makes no commitment to update or keep current the information contained in this document. No part of this document may be copied or reproduced in any form or by any means without the prior written consent of MOSEL-VITELIC.

MOSEL VITELIC subjects its products to normal quality control sampling techniques which are intended to provide an assurance of high quality products suitable for usual commercial applications. MOSEL VITELIC does not do testing appropriate to provide 100% product quality assurance and does not assume any liability for consequential or incidental arising from any use of its products. If such products are to be used in applications in which personal injury might occur from failure, purchaser must do its own quality assurance testing appropriate to such applications.