

TOSHIBA CMOS Digital Integrated Circuit Silicon Monolithic

TC74AC138P, TC74AC138F, TC74AC138FN, TC74AC138FT

3-to-8 Line Decoder

The TC74AC138 is an advanced high speed CMOS 3-to-8 LINE DECODER fabricated with silicon gate and double-layer metal wiring C2MOS technology.

It achieves the high speed operation similar to equivalent Bipolar Schottky TTL while maintaining the CMOS low power dissipation.

When the device is enabled, 3 Binary Select inputs (A, B and C) determine which one of the outputs ($\overline{Y}0 - \overline{Y}7$) will go low.

When enable input G1 is held low or either $\overline{G}2A$ or $\overline{G}2B$ is held high, decoding function is inhibited and all outputs go high.

G1, $\overline{G}2A$, and $\overline{G}2B$ inputs are provided to ease cascade connection and for use as an address decoder for memory systems.

All inputs are equipped with protection circuits against static discharge or transient excess voltage.

Features

- High speed: $t_{pd} = 5.9$ ns (typ.) at $V_{CC} = 5$ V
- Low power dissipation: $I_{CC} = 8$ μ A (max) at $T_a = 25^\circ$ C
- High noise immunity: $V_{NIH} = V_{NIL} = 28\%$ V_{CC} (min)
- Symmetrical output impedance: $|I_{OH}| = I_{OL} = 24$ mA (min)
Capability of driving 50 Ω transmission lines.
- Balanced propagation delays: $t_{pLH} \approx t_{pHL}$
- Wide operating voltage range: $V_{CC(opr)} = 2$ to 5.5 V
- Pin and function compatible with 74F138

Note: xxxFN (JEDEC SOP) is not available in Japan.

TC74AC138P

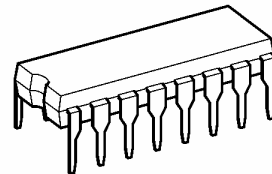

DIP16-P-300-2.54A

TC74AC138F

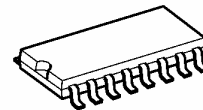

SOP16-P-300-1.27A

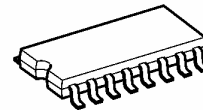

SOP16-P-300-1.27

TC74AC138FN

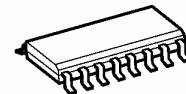

SOL16-P-150-1.27

TC74AC138FT

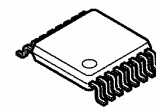

TSSOP16-P-0044-0.65A

Weight	
DIP16-P-300-2.54A	: 1.00 g (typ.)
SOP16-P-300-1.27A	: 0.18 g (typ.)
SOP16-P-300-1.27	: 0.18 g (typ.)
SOL16-P-150-1.27	: 0.13 g (typ.)
TSSOP16-P-0044-0.65A	: 0.06 g (typ.)

Pin Assignment

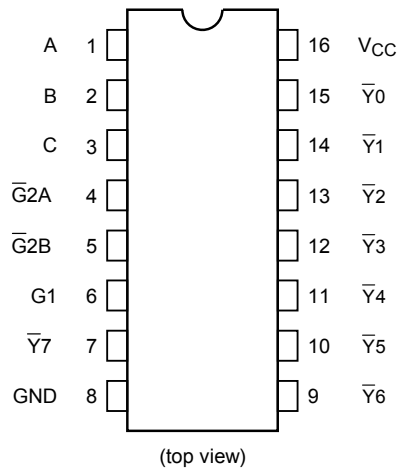

IEC Logic Symbol

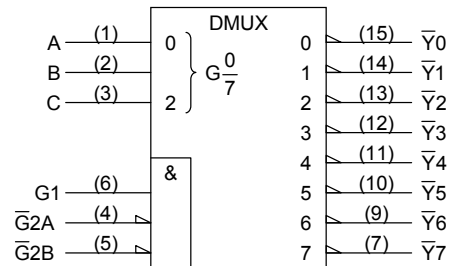
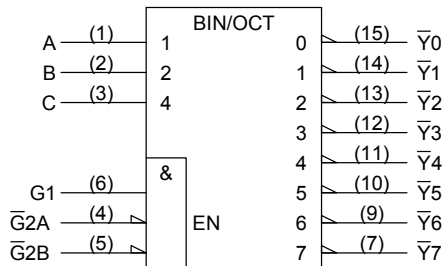

Truth Table

Inputs						Outputs								Selected Output
Enable			Select			$\bar{Y}0$	$\bar{Y}1$	$\bar{Y}2$	$\bar{Y}3$	$\bar{Y}4$	$\bar{Y}5$	$\bar{Y}6$	$\bar{Y}7$	
G1	$\bar{G}2A$	$\bar{G}2B$	C	B	A									
L	X	X	X	X	X	H	H	H	H	H	H	H	H	None
X	H	X	X	X	X	H	H	H	H	H	H	H	H	None
X	X	H	X	X	X	H	H	H	H	H	H	H	H	None
H	L	L	L	L	L	L	H	H	H	H	H	H	H	$\bar{Y}0$
H	L	L	L	L	H	H	L	H	H	H	H	H	H	$\bar{Y}1$
H	L	L	L	H	L	H	H	L	H	H	H	H	H	$\bar{Y}2$
H	L	L	L	H	H	H	H	H	L	H	H	H	H	$\bar{Y}3$
H	L	L	H	L	L	H	H	H	H	L	H	H	H	$\bar{Y}4$
H	L	L	H	L	H	H	H	H	H	H	L	H	H	$\bar{Y}5$
H	L	L	H	H	L	H	H	H	H	H	H	L	H	$\bar{Y}6$
H	L	L	H	H	H	H	H	H	H	H	H	H	L	$\bar{Y}7$

X: Don't care

Logic Diagram

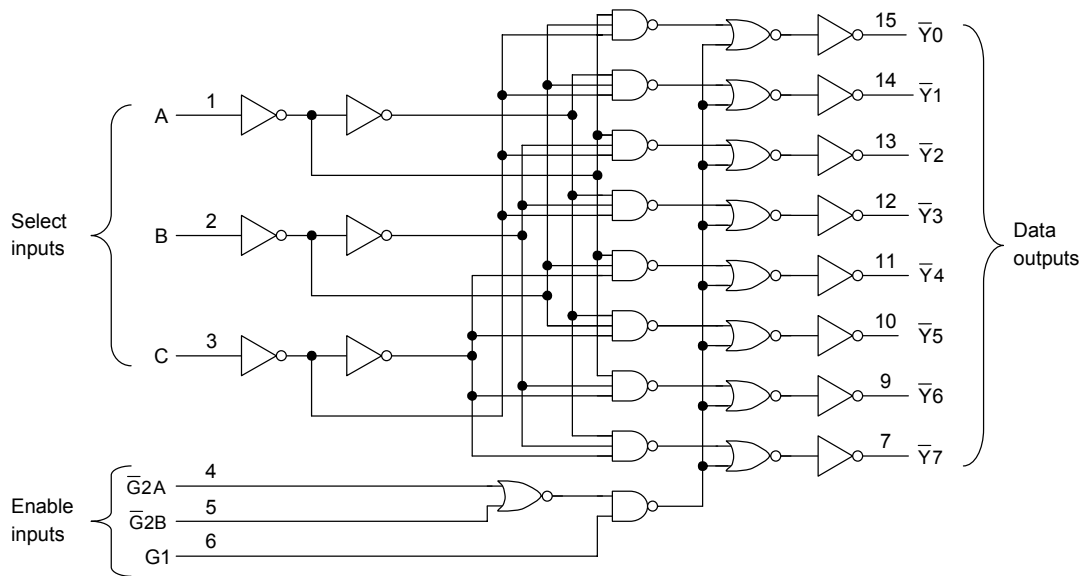

Absolute Maximum Ratings (Note 1)

Characteristics	Symbol	Rating	Unit
Supply voltage range	V_{CC}	-0.5 to 7.0	V
DC input voltage	V_{IN}	-0.5 to $V_{CC} + 0.5$	V
DC output voltage	V_{OUT}	-0.5 to $V_{CC} + 0.5$	V
Input diode current	I_{IK}	± 20	mA
Output diode current	I_{OK}	± 50	mA
DC output current	I_{OUT}	± 50	mA
DC V_{CC} /ground current	I_{CC}	± 200	mA
Power dissipation	P_D	500 (DIP) (Note 2)/180 (SOP/TSSOP)	mW
Storage temperature	T_{stg}	-65 to 150	$^{\circ}C$

Note1: Exceeding any of the absolute maximum ratings, even briefly, lead to deterioration in IC performance or even destruction.

Note2: 500 mW in the range of $T_a = -40$ to $65^{\circ}C$. From $T_a = 65$ to $85^{\circ}C$ a derating factor of -10 mW/ $^{\circ}C$ should be applied up to 300 mW.

Recommended Operating Conditions (Note)

Characteristics	Symbol	Rating	Unit
Supply voltage	V_{CC}	2.0 to 5.5	V
Input voltage	V_{IN}	0 to V_{CC}	V
Output voltage	V_{OUT}	0 to V_{CC}	V
Operating temperature	T_{opr}	-40 to 85	$^{\circ}C$
Input rise and fall time	dt/dV	0 to 100 ($V_{CC} = 3.3 \pm 0.3$ V) 0 to 20 ($V_{CC} = 5 \pm 0.5$ V)	ns/V

Note: The recommended operating conditions are required to ensure the normal operation of the device. Unused inputs must be tied to either VCC or GND.

Electrical Characteristics

DC Characteristics

Characteristics	Symbol	Test Condition	V _{CC} (V)	Ta = 25°C			Ta = -40 to 85°C		Unit	
				Min	Typ.	Max	Min	Max		
High-level input voltage	V _{IH}	—	2.0	1.5	—	—	1.5	—	V	
			3.0	2.10	—	—	2.10	—		
			5.5	3.85	—	—	3.85	—		
Low-level input voltage	V _{IL}	—	2.0	—	—	0.50	—	0.50	V	
			3.0	—	—	0.90	—	0.90		
			5.5	—	—	1.65	—	1.65		
High-level output voltage	V _{OH}	V _{IN} = V _{IH} or V _{IL}	I _{OH} = -50 μA	2.0	1.9	2.0	—	1.9	—	V
				3.0	2.9	3.0	—	2.9	—	
				4.5	4.4	4.5	—	4.4	—	
			I _{OH} = -4 mA	3.0	2.58	—	—	2.48	—	
				4.5	3.94	—	—	3.80	—	
I _{OH} = -75 mA (Note)	5.5	—	—	—	3.85	—				
Low-level output voltage	V _{OL}	V _{IN} = V _{IH} or V _{IL}	I _{OL} = 50 μA	2.0	—	0.0	0.1	—	0.1	V
				3.0	—	0.0	0.1	—	0.1	
				4.5	—	0.0	0.1	—	0.1	
			I _{OL} = 12 mA	3.0	—	—	0.36	—	0.44	
				4.5	—	—	0.36	—	0.44	
I _{OL} = 75 mA (Note)	5.5	—	—	—	—	1.65				
Input leakage current	I _{IN}	V _{IN} = V _{CC} or GND	5.5	—	—	±0.1	—	±1.0	μA	
Quiescent supply current	I _{CC}	V _{IN} = V _{CC} or GND	5.5	—	—	8.0	—	80.0	μA	

Note: This spec indicates the capability of driving 50 Ω transmission lines.

One output should be tested at a time for a 10 ms maximum duration.

AC Characteristics ($C_L = 50 \text{ pF}$, $R_L = 500 \text{ } \Omega$, input: $t_r = t_f = 3 \text{ ns}$)

Characteristics	Symbol	Test Condition	V_{CC} (V)	$T_a = 25^\circ\text{C}$			$T_a = -40 \text{ to } 85^\circ\text{C}$		Unit
				Min	Typ.	Max	Min	Max	
Propagation delay time (A, B, C- \bar{Y})	t_{pLH}	—	3.3 ± 0.3	—	8.5	14.2	1.0	16.3	ns
	t_{pHL}		5.0 ± 0.5	—	6.4	9.2	1.0	10.5	
Propagation delay time (G1- \bar{Y})	t_{pLH}	—	3.3 ± 0.3	—	7.5	12.8	1.0	14.7	ns
	t_{pHL}		5.0 ± 0.5	—	6.1	8.9	1.0	10.2	
Propagation delay time ($\bar{G}2$ - \bar{Y})	t_{pLH}	—	3.3 ± 0.3	—	8.8	15.0	1.0	17.3	ns
	t_{pHL}		5.0 ± 0.5	—	7.2	10.5	1.0	12.0	
Input capacitance	C_{IN}	—	—	5	10	—	10	pF	
Power dissipation capacitance	C_{PD}	(Note)	—	143	—	—	—	pF	

Note: C_{PD} is defined as the value of the internal equivalent capacitance which is calculated from the operating current consumption without load.

Average operating current can be obtained by the equation:

$$I_{CC(\text{opr})} = C_{PD} \cdot V_{CC} \cdot f_{IN} + I_{CC}$$

Package Dimensions

DIP16-P-300-2.54A

Unit : mm

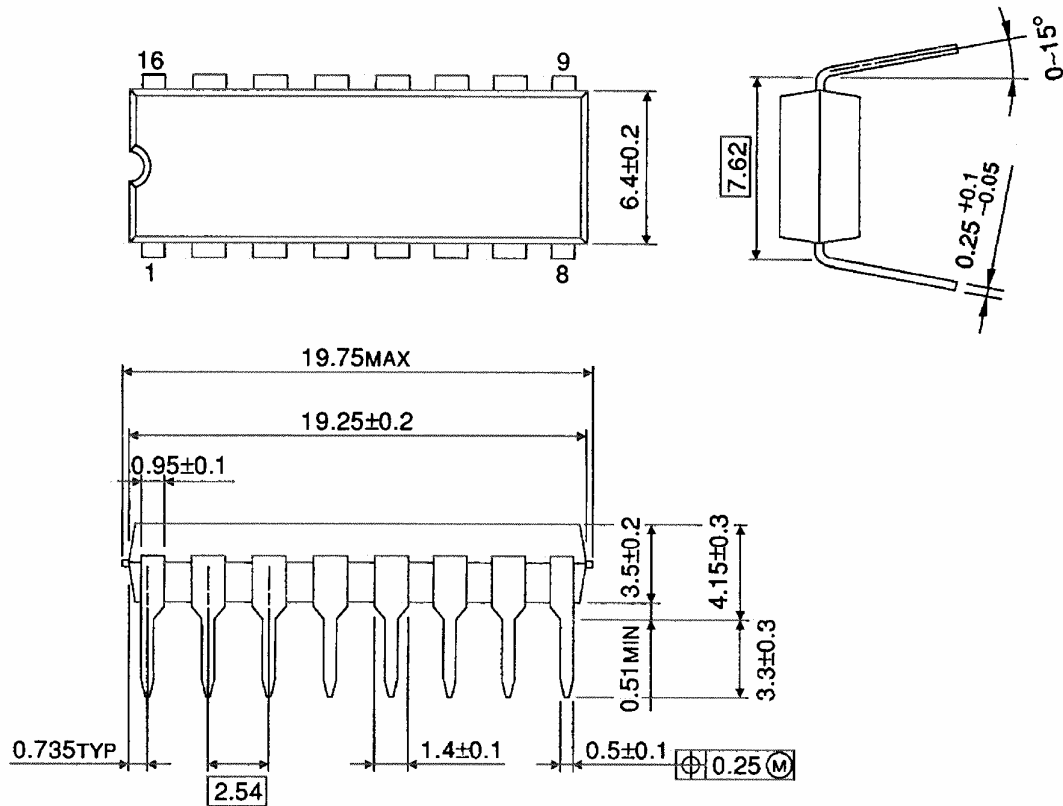

Weight: 1.00 g (typ.)

Package Dimensions

SOP16-P-300-1.27A

Unit: mm

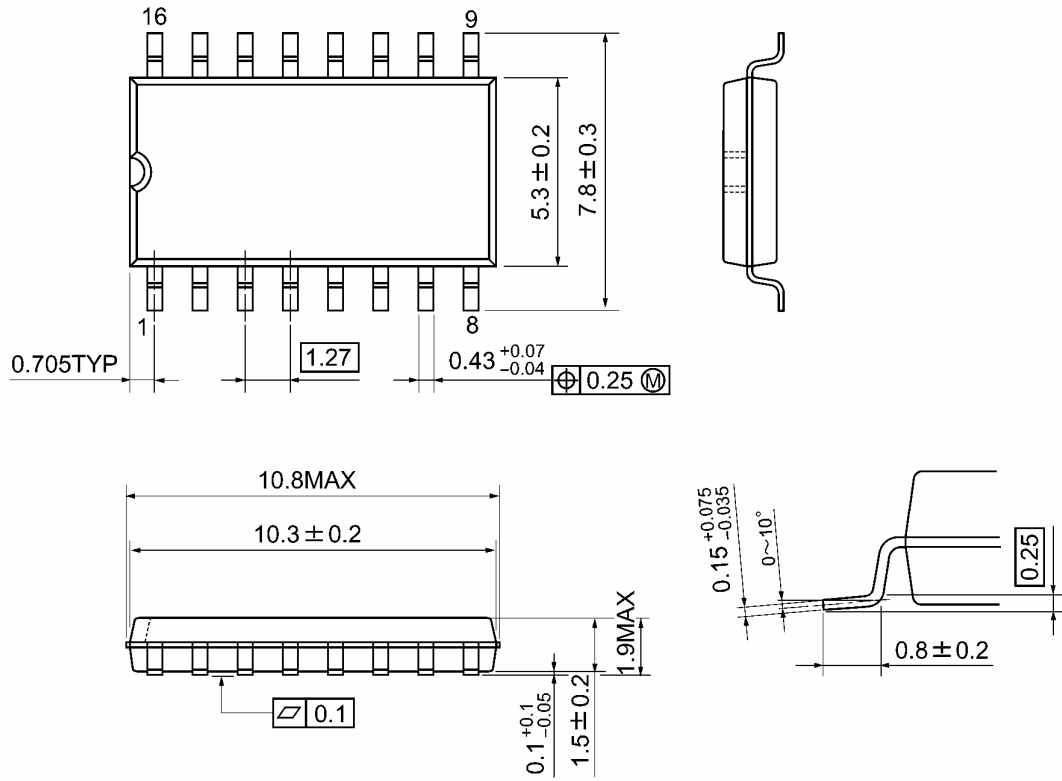

Weight: 0.18 g (typ.)

Package Dimensions

SOP16-P-300-1.27

Unit : mm

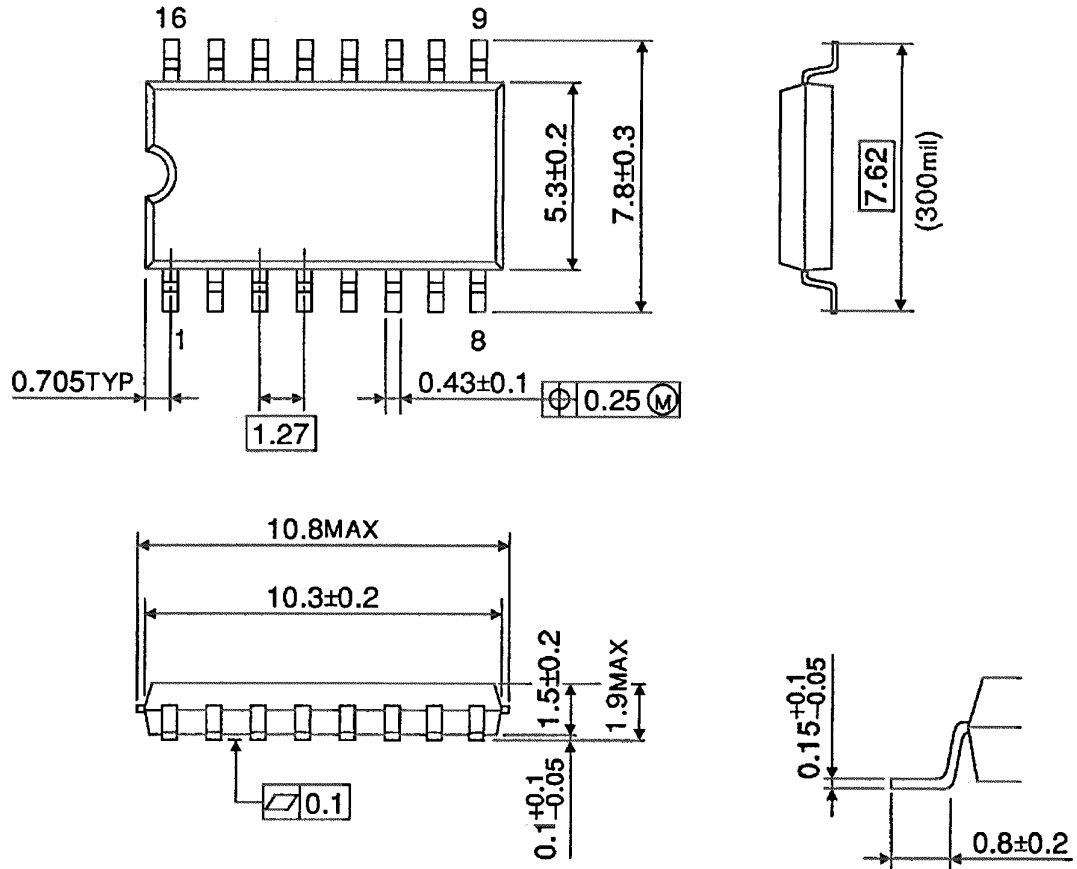

Weight: 0.18 g (typ.)

Package Dimensions (Note)

SOL16-P-150-1.27

Unit : mm

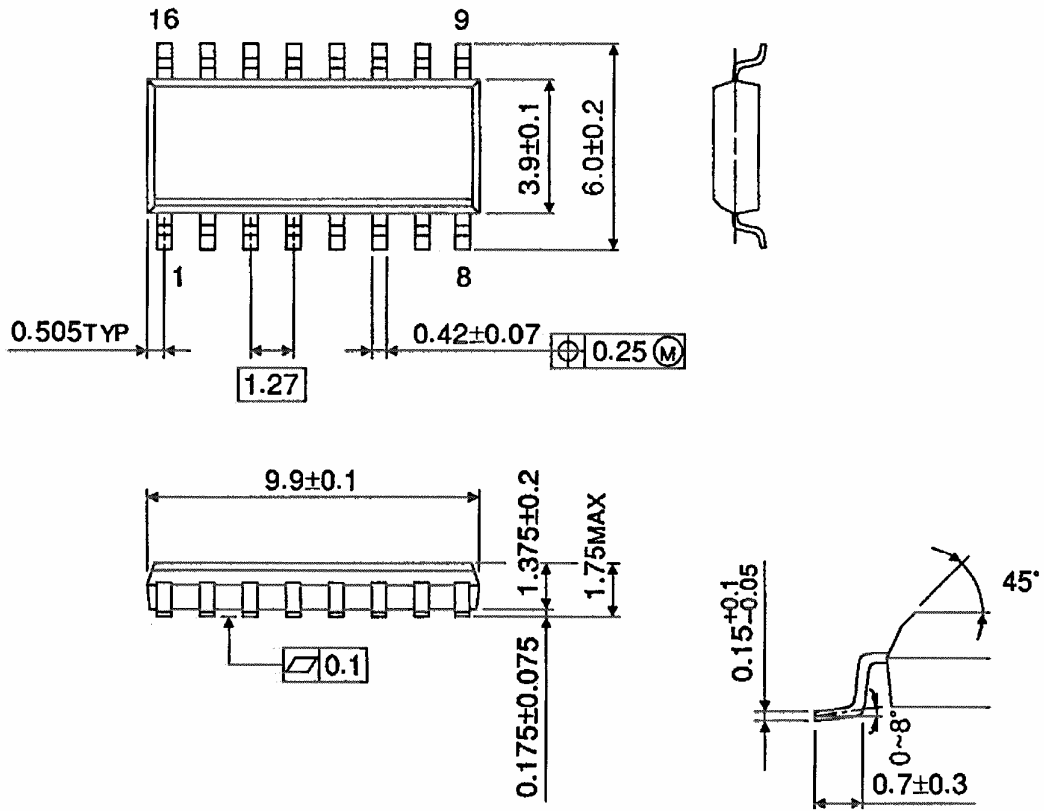

Note: This package is not available in Japan.

Weight: 0.13 g (typ.)

Package Dimensions

TSSOP16-P-0044-0.65A

Unit: mm

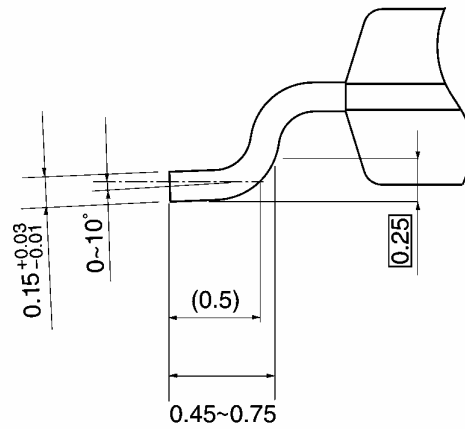
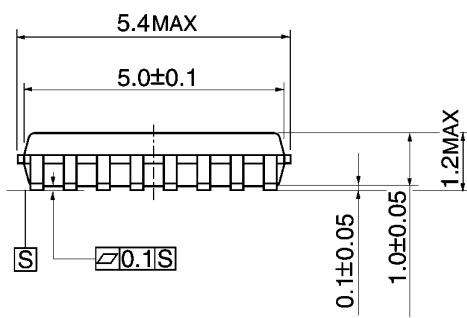
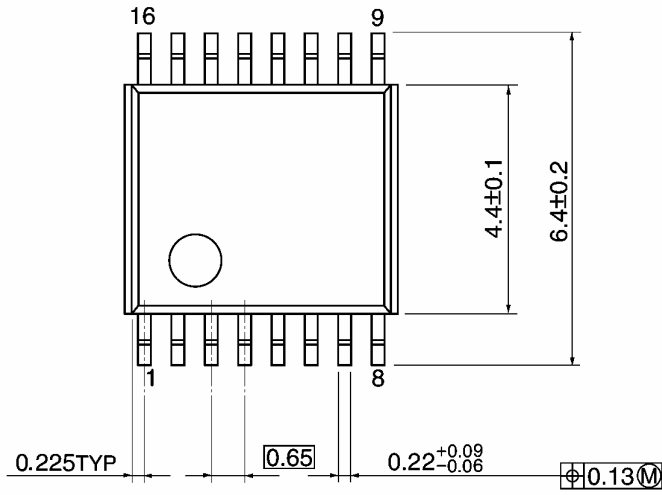

Weight: 0.06 g (typ.)

Note: Lead (Pb)-Free Packages**DIP16-P-300-2.54A SOP16-P-300-1.27A SOL16-P-150-1.27 TSSOP16-P-0044-0.65A****RESTRICTIONS ON PRODUCT USE**

060116EBA

- The information contained herein is subject to change without notice. 021023_D
- TOSHIBA is continually working to improve the quality and reliability of its products. Nevertheless, semiconductor devices in general can malfunction or fail due to their inherent electrical sensitivity and vulnerability to physical stress. It is the responsibility of the buyer, when utilizing TOSHIBA products, to comply with the standards of safety in making a safe design for the entire system, and to avoid situations in which a malfunction or failure of such TOSHIBA products could cause loss of human life, bodily injury or damage to property.
In developing your designs, please ensure that TOSHIBA products are used within specified operating ranges as set forth in the most recent TOSHIBA products specifications. Also, please keep in mind the precautions and conditions set forth in the "Handling Guide for Semiconductor Devices," or "TOSHIBA Semiconductor Reliability Handbook" etc. 021023_A
- The TOSHIBA products listed in this document are intended for usage in general electronics applications (computer, personal equipment, office equipment, measuring equipment, industrial robotics, domestic appliances, etc.). These TOSHIBA products are neither intended nor warranted for usage in equipment that requires extraordinarily high quality and/or reliability or a malfunction or failure of which may cause loss of human life or bodily injury ("Unintended Usage"). Unintended Usage include atomic energy control instruments, airplane or spaceship instruments, transportation instruments, traffic signal instruments, combustion control instruments, medical instruments, all types of safety devices, etc. Unintended Usage of TOSHIBA products listed in this document shall be made at the customer's own risk. 021023_B
- The products described in this document shall not be used or embedded to any downstream products of which manufacture, use and/or sale are prohibited under any applicable laws and regulations. 060106_Q
- The information contained herein is presented only as a guide for the applications of our products. No responsibility is assumed by TOSHIBA for any infringements of patents or other rights of the third parties which may result from its use. No license is granted by implication or otherwise under any patent or patent rights of TOSHIBA or others. 021023_C
- The products described in this document are subject to the foreign exchange and foreign trade laws. 021023_E