



Section 15: SEMICELL[®] Power Semiconductor Chips

The following tables contain our standard types. Other types or selections are available on special request. Please contact your SEMIKRON office.

SEMICELL[®] Rectifier Diode Chips

Types  	V _{RRM} , V _{RRM} ¹⁾ 100 V	V _{RSM} , V _{RRM} ¹⁾ V	I _{FAV} max. A	at		I _{FSM} 10 ms A	V _F at T _{vj} = 25 °C		V _(TO) V	r _T mΩ	T _{vjmax} ⁶⁾ °C	Fig.	a mm
				T _{case} (T _{amb}) °C	R _{thjc} (R _{thja}) °C/W		V _F V	I _F A					
SKN-SW 2,5/..	200 ... 1600	1,3	(45)	(80)	50	1,6	10	0,85	90	150	1	2,5	
SKN-SW 2,5/..	200 ... 800	1,4	(45)	(80)	100	1,3	10	0,85	50	150	1	2,5	
SKN-SW 3,5/..	200 ... 1600	2,5	(45)	(40)	150	1,2	10	0,85	30	150	1	3,5	
SKN-SW 5 /..	200 ... 1600	25	100	2	320	1,55	60	0,85	11	150	1	5	
SKN-TABL 8H/..	200 ... 1600	50	100	1,1	640	1,8	150	0,85	8	180	2	8	
SKN-TABL 9H/..	200 ... 1600	95	100	0,55	1000	1,5	200	0,85	3	180	2	9	
SKN-TABL 11H/..	200 ... 1600	125	100	0,45	1500	1,55	400	0,85	1,8	180	2	11	
SKN-TABL 8,3 QU/..	200 ... 1600	45	86	0,6	600	1,95	250	0,85	5	180		8,3	
SKN-TABL 11,3 QU/..	200 ... 1600	100	85	0,35	2000	1,35	300	0,85	1,3	180		11,3	
SKN-TABL 11RD/..	200 ... 1600	125	100	0,45	1500	1,55	400	0,85	1,8	180	3	11	
SKN-TABL 13RD/..	200 ... 1600	160	100	0,35	2000	1,5	500	0,85	1,3	180	3	13,5	
SKN-TABL 18RD/..	200 ... 1600	320	100	0,20	5000	1,4	750	0,85	0,6	180	3	19	
SKN-TABL 23RD/..	200 ... 1600	420	100	0,16	8000	1,35	1000	0,85	1,45	180	3	24	
SKR-TABL 4,2QU/.. ^{5,6)}	800 ... 1800	25	80	1,6	350	1,1	25	0,8	13	150	8	4,2	
SKR-TABL 5,6QU/.. ^{5,6)}	800 ... 1800	35	80	1,2	750	1,1	35	0,8	11	150	8	5,6	
SKR-TABL 6,2QU/.. ^{5,6)}	800 ... 1800	40	80	1,1	900	1,2	50	0,8	8,5	150	8	6,2	
SKR-TABL 7,0QU/.. ^{5,6)}	800 ... 1800	75	80	0,7	1150	1,15	75	0,8	7	150	8	7,0	
SKR-TABL 8,9QU/.. ^{5,6)}	800 ... 1800	90	80	0,5	1700	1,2	125	0,8	4	150	8	8,9	
SKR-GSW18,2QU/.. ²⁾	800 ... 1800	250	80	0,18	6000	1,2	500	0,8	1	150	7	18,2	

SEMICELL[®] Fast Rectifier Diode Chips

Types ¹⁾ 	V _{RRM} , V _{RRM} ¹⁾ V	I _{FAV} max. A	at		I _{FSM} 10 ms A	V _F at T _{vj} = 25 °C		V _(TO) V	r _T mΩ	t _{rr} 25 °C μs	T _{vjmax} ⁶⁾ °C	Fig.	a mm
			T _{case} (T _{amb}) °C	R _{thjc} (R _{thja}) °C/W		V _F V	I _F A						
SW 2,5 F/..	100 ... 800	1,2	(45)	(60)	60	1,5	10	1,0	50	0,45	130	1	2,5
SW 3,5 F/..	100 ... 800	2,0	(45)	(40)	200	1,25	10	1,0	20	0,45	130	1	3,5
SW 5 F/..	100 ... 1200	21	100	1,2	310	2,15	50	1,3	12	0,25	150	1	5
TABL 8 RDF	200 ... 1000	52	100	0,5	940	1,8	50	1,2	4	0,20	150	3	9
TABL11 RDF	200 ... 1500	60	100	0,5	1200	1,75	150	1,0	4	0,5	150	3	11
TABL14 RDF 1	600 ... 1500	140	100	0,2	2100	1,80	300	1,1	2	0,8	150	3	14
TABL14 RDF 2	600 ... 1200	135	100	0,2	2100	1,95	300	1,1	2,3	0,5	150	3	14
TABL18 RDM	200 ... 1500	170	85	0,2	3000	1,3	500	0,9	0,6	2	125	3	18

Remarks

¹⁾ Available selections for V_{RRM} ≥ 800 V ... 1000 V; e.g. SKR-TABL 4,2 QU/08...10 ≥ 1200 V ... 1400 V; e.g. SKR-TABL 4,2 QU/12...14 ≥ 1600 V ... 1800 V; e.g. SKR-TABL 4,2 QU/16...18

²⁾ GSW = glass passivated sandwich: Molybdenum / Siliconchip/Molybdenum
³⁾ SKN-TABL = silicone passivated silicon diode chip, Mesa edge, Top = cathode (solderable); Bottom = anode (solderable)

⁴⁾ SKR-TABL = Glass passivated silicon diode chip; Bottom = cathode Mesa edge, Top = anode (solderable), Bottom = cathode (solderable)

⁵⁾ Metallisation of Version "B": Top = anode is bondable AL-contact; bondable area = (a - 1,4) x (a - 1,4); add suffix "B" (on request); I_{FSM} depends on number of bonds
⁶⁾ Soldering temperature = 255 ± 5 °C

8136671 0006705 592

SEMICELL® Ultrafast Epitaxial Rectifier Diode Chips

Types	V _{RSM} , V _{RRM}		I _{FAV}	at		I _{FSM}	V _F at		V _(TO)	r _T	t _r	T _{vjmax} ⁸⁾	Fig.	a
	max.			T _{case}	R _{thjc}		T _{vj = 25 °C}	I _F						
	V		A	°C	°C/W	A	V	A	V	mΩ	ns	°C		mm
SKCD 47E..B ⁹⁾	50 ... 400	40	100	0,85	700	1,6	120	0,8	6,5	60	150	4 a	7	
SKR-Tabl.13,3QE..	50 ... 300	200	85	0,22	2800	1,55	500	0,75	1,5	100	150	4 b	13,3	

SEMICELL® Thyristor Chips

Types ¹⁾ 本	I _{TAV} at		I _{TSM}	V _T at		V _{T(TO)}	r _T	(dv/dt) _{cr} ⁸⁾	(di/dt) _{cr}	V _{GT}	I _{GT}	V _{GD}	I _{GD}
	T _{case} = 85 °C			T _{vj = 25 °C}									
	max	R _{thjc}	T _{vjmax}	I _T	T _{vjmax}	V	mΩ	V/μs	A/μs	25 °C	T _{vjmax}		
V	°C/W	A	A	A	V				V	mA	V	mA	
SKT-GSW 5,6Q1/..	16	0,9	300	2,4	75	1,0	20	1000	125	3	100	0,25	3
SKT-GSW 7 Q1/..	25	0,95	400	1,8	75	1,0	10	1000	125	3	100	0,25	3
SKT-GSW 8,9Q1/..	45	0,60	1000	1,8	120	1,1	5	1000	125	3	150	0,25	5
SKT-GSW 10,3Q1/..	50	0,60	1250	1,65	200	0,9	3,5	1000	100	3	150	0,25	6
SKT-GSW 12,4Q1/..	90	0,30	1750	1,65	300	0,9	2	1000	100	3	150	0,25	6
SKT-GSW 18,2QU/..	160	0,18	4000	1,80	500	0,85	1,5	1000	100	3	150	0,25	10
SKT-TABL 5,6QU/.. ⁵⁾	16	0,9	370	2,4	75	1,0	20	1000	50	3	100	0,25	3
SKT-TABL 7 QU/.. ⁵⁾	24	0,9	450	1,8	75	1,0	10	1000	50	3	100	0,25	3
SKT-TABL 8,9QU/.. ⁵⁾	45	0,6	1050	1,8	120	1,1	5	1000	50	3	150	0,25	5
SKT-TABL 8,9QU/..ZG ^{7, 5)}	45	0,6	1050	1,8	120	1,1	5	1000	50	3	150	0,25	5
SKT-TABL 10,3QU/..	55	0,6	1250	1,65	200	0,9	3,5	1000	100	3	150	0,25	6
SKT-TABL 10,3QU/..ZG ⁷⁾	55	0,6	1250	1,65	200	0,9	3,5	1000	100	3	150	0,25	6
SKT-TABL 12,4QU/..	95	0,3	1750	1,65	300	0,9	2	1000	100	3	150	0,25	6
SKT-TABL 12,4QU/..ZG ⁷⁾	95	0,3	1750	1,65	300	0,9	2	1000	100	3	150	0,25	6
SKT-TABL C 24 N/..	160	0,18	3750	1,75	500	1	1,5	1000	125	3	200	0,25	8
SKT-TABL C 30 N/..	300	0,11	7000	1,45	800	0,9	0,6	1000	125	3	200	0,25	8

Remarks:

- Available selections for V_{DRM}, V_{RRM}: ≥ 800 V ... 1000 V; e.g. SKT-GSW 5,6 Q1/08
≥ 1200 V ... 1600 V; e.g. SKT-GSW 5,6 Q1/12..16
≥ 1600; e.g. SKT-GSW 5,6 Q1/16
- GSW = glass passivated sandwich: Molybdenum / Siliconchip/Molybdenum
- TABL = glass passivated silicon chip, Metallisation: Bottom = anode (solderable), Top = cathode (solderable) → 5)
- I_R, I_D (V_R = V_{RRM}, V_D = V_{DRM}, T_j = 25 °C) ≤ 0,3 mA
I_R, I_D (V_R = V_{RRM}, V_D = V_{DRM}, T_j = 130 °C) ≤ 8 mA
- Metallisation of version "B" (add suffix B): Top = cath., bondable, on request
- (dv/dt)_{cr} as per AQL 2,5
- ZG = Central gate (all others have "edge gate" see Fig. 5 and Fig. 6)
- Soldering temperature = 255 ± 5 °C
- Metallization of version "S": Top = anode is solderable contact (solderable area = 4,8 mm)
add suffix "S" (on request)

Fig. 4c GMCL04C

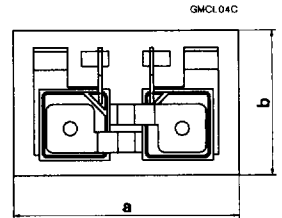

SEMICELL® Chips on Ceramic Substrate

Custom Designs on request

e.g. 2 antiparallel thyristor chips on ceramic substrate (in W1C circuit) → Fig. 4c
I_{RMS} = 25 ... 100 A / V_{DRM} = 800 ... 1600 V

8136671 0006706 429

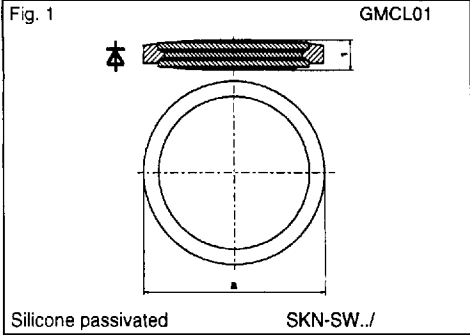

I_H 25 °C	I_L 25 °C	t_q T_{vjmax} typ. μs	T_{vj} max 8) °C	Fig.	a
mA	mA				mm
120	300		130	5	5,6
200	400		130	5	7
250	600	150	130	5	8,9
250	600	150	130	5	11
250	600	150	130	5	12,4
400	1000	150	130	5	
150	300	150	130	9	5,6
150	400	150	130	9	7
200	400	150	130	9	8,9
200	400	150	130	10	8,9
250	600	150	130	9	10,3
250	600	150	130	10	10,3
250	600	150	130	9	12,4
250	600	150	130	10	12,4
250	600	150	130	6	24
250	600	150	130	6	30

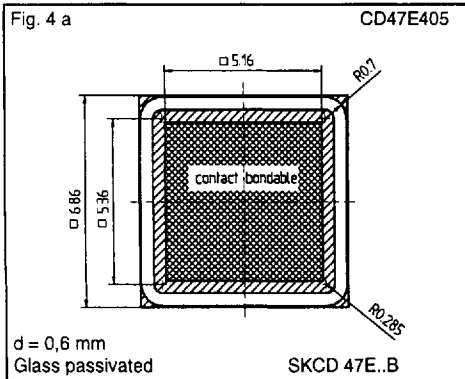
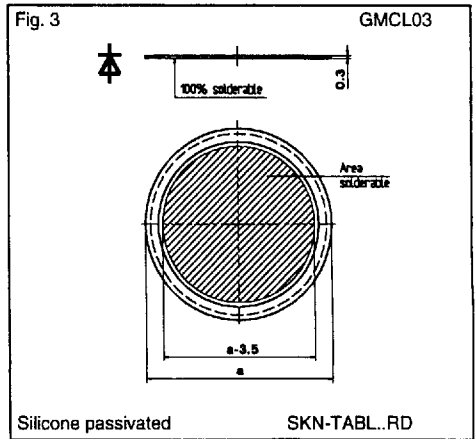
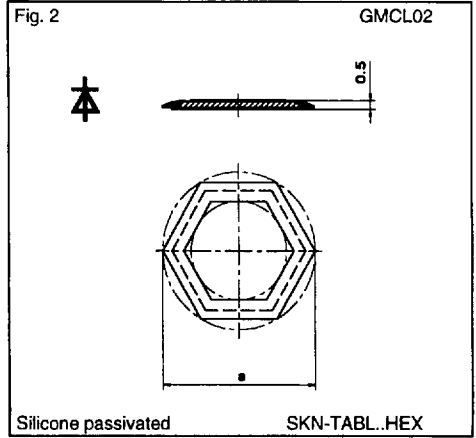

Dimensions in mm

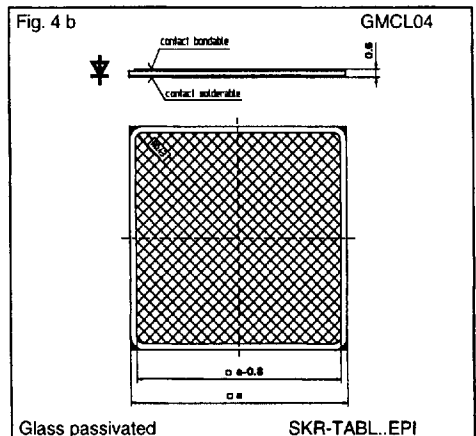
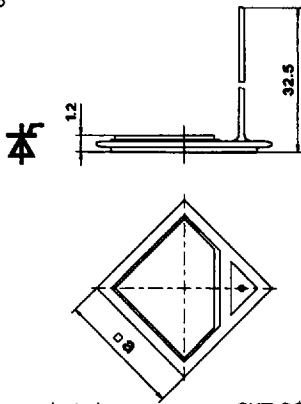
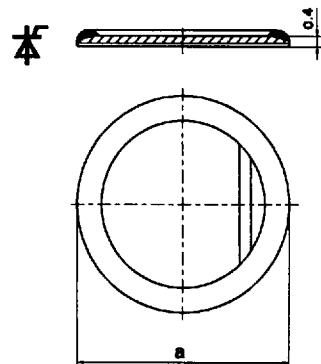

Fig. 5 GMCL05



Glass passivated SKT-GSW..QU/

Fig. 6 GMCL06



Silicone passivated SKT-TABLC..RD

Fig. 7 GMCL07

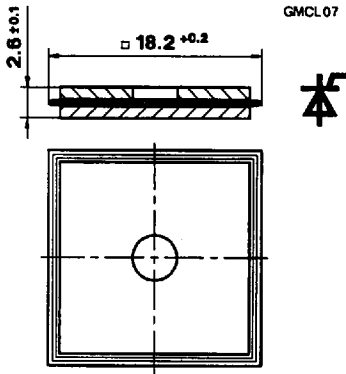

Glass passivated SKR-GSW 18.2 QU

Fig. 8 GMCL08

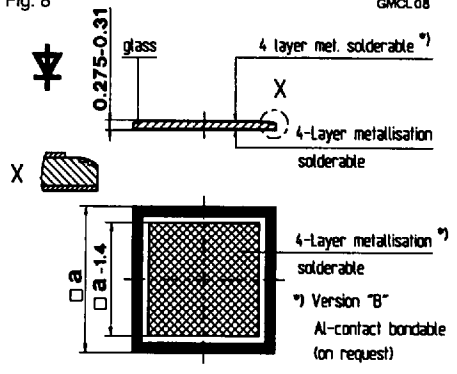

Glass passivated SKR-TABL..QU/..(B)

Fig. 9 GMCL09

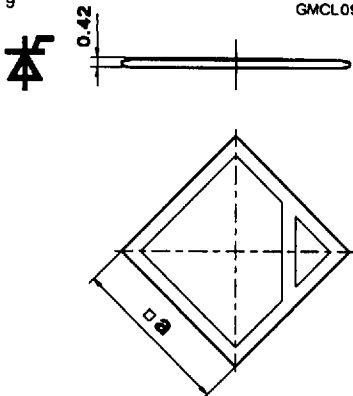

Glass passivated SKT-TABL..QU/

Fig. 10 GMCL10

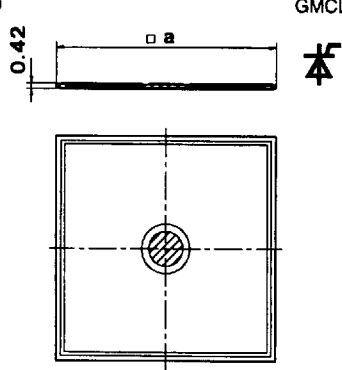

Glass passivated SKT-TABL/.. ZG

Dimensions in mm

8136671 0006708 2T1