

Table of Models

	<p>Description: Peel-A-Way® (KSS) Material: Polyimide Film Index: -269°C to 400°C (-452°F to 752°F)</p>	
	<p>Description: Molded Snap Strips (RSS, RLSS) Material: High Temp. Liquid Crystal Polymer (LCP) Index: -40°C to 260°C (-40°F to 500°F)</p>	
	<p>Description: Molded Solid Strips (RNB, RLNB) Material: High Temp. Liquid Crystal Polymer (LCP) Index: -40°C to 260°C (-40°F to 500°F)</p>	

Features:

- Available in three body types: Peel-A-Way® Removable Terminal Carriers, molded Solid Strips, and molded Snap Strips [breakable at .100/(2.54mm)].
- Tapered entry for ease of insertion.
- Multi-finger contacts for reliability.
- Closed bottom sleeve for 100% anti-wicking of solder.
- Custom configurations available.

Specifications:

Terminals:

Brass - Copper Alloy
(C36000) ASTM-B-16

Contacts:

Beryllium Copper
(C17200) ASTM-B-194

Solder Preform:

Standard: 63Sn/37Pb
Lead-free: 95.5Sn/4.0Ag/0.5Cu

Plating:

G - Gold over Nickel
M - Matte Tin over Nickel
T - Tin/Lead over Nickel

Gold per MIL-G-45204
Matte Tin per ASTM545-97
Tin/Lead per MIL-P-81728
Nickel per QQ-N-290

RSS/RLSS replaces HSS/HLSS and SS/LSS
RNB/RLNB replaces HNB/HLNB and NB/LNB

Options

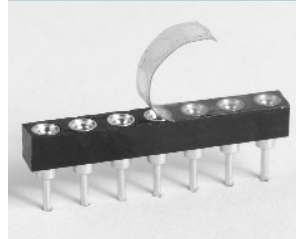

Tape Sealant - add 3M to end of part number

- Removable tape seal protects plated contact in harsh environments
- Sealed socket will not allow dirt and other contaminants to enter socket chamber and become entrapped behind contact fingers
- Spray flux without contaminating contact area
- Material - Silicone Backed Polyimide Film, -74°C to 260°C (-100°F to 500°F) Intermittent to 371°C (700°F)

Dimensional Information

Molded Body Types

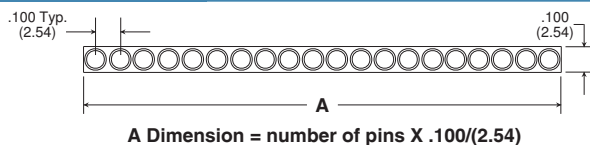

Peel-A-Way® Body Types

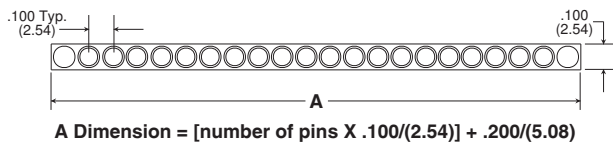

How To Order

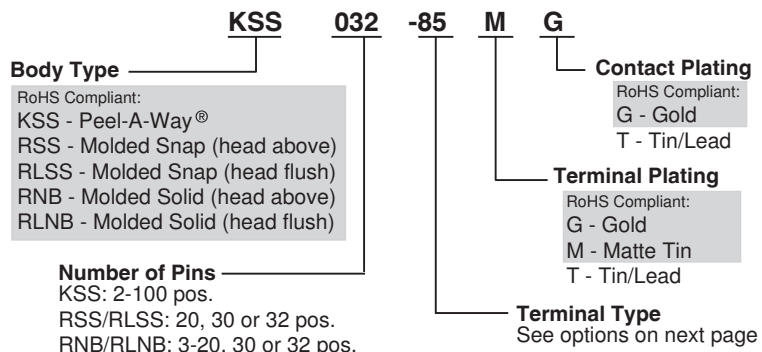

Note: Terminals plated with Matte Tin are available only with Gold plated contacts.
 Quick-Turn delivery is not available on products with Matte Tin plating.

Products shown covered by patents issued and/or pending. Specifications subject to change without notice.

inch/(mm)



Additional standard and custom terminals available.
See Terminals section online or consult factory.

Standard Quick-Turn Terminals

Type -51	Type -04	Type -49	Type -01
<p>.072 Dia. (1.83) .130 (3.30) .110 (2.79) .020 Dia. (.51)</p>	<p>.072 Dia. (1.83) .120 (3.05) .110 (2.79) .028 Dia. (.71)</p>	<p>Not for use with head above</p> <p>.072 Dia. (1.83) .095 (2.41) .021 Hole (.53) Dia. .095 (2.41) .028 Dia. (.71)</p>	<p>Molded only</p> <p>.072 Dia. (1.83) .145 (3.68) .165 (4.19) .125 (3.18) .020 Dia. (.51)</p>
Type -33	Type -85	Type -176	Type -210
<p>Peel-A-Way® only</p> <p>.072 Dia. (1.83) .165 (4.19) .125 (3.18) .020 Dia. (.51)</p>	<p>Peel-A-Way® only</p> <p>.058 Dia. (1.47) .031 (.79) .155 (3.94) .038 Dia. (.97)</p>	<p>Peel-A-Way® only</p> <p>.058 Dia. (1.47) .031 (.79) .155 (3.95) .034 Dia. (.86)</p>	<p>Peel-A-Way® only</p> <p>.058 Dia. (1.47) .015 (.38) .155 (3.94) .034 Dia. (.86)</p>

Solder Preform Terminals

Tin/Lead: Type -150 Lead-free: Type -811	Tin/Lead: Type -151 Lead-free: Type -812	Tin/Lead: Type -111 Lead-free: Type -810
<p>.072 Dia. (1.83) .165 (4.19) .125 (3.18) .020 Dia. (.51)</p> <p>Solder Preform</p>	<p>.072 Dia. (1.83) .130 (3.30) .110 (2.79) .020 Dia. (.51)</p> <p>Solder Preform</p>	<p>Peel-A-Way® only</p> <p>.058 Dia. (1.47) .031 (.79) .155 (3.94) .038 Dia. (.97)</p> <p>Solder Preform</p>

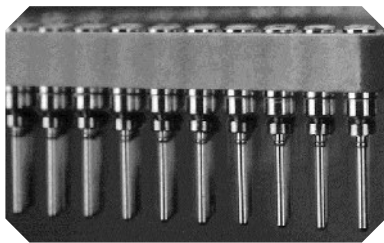

Intrusive Reflow Application

- Combines the labor of socket loading and solder application into one operation.
- Eliminates the use of solder paste and screening operation.
- Eliminates solder bridges and/or solder shorts due to excess solder.
- Ensures a reliable solder joint with controlled solder volume.
- Ideal for surface mount and mixed technology applications.
- For custom solder preform terminal applications consult factory.

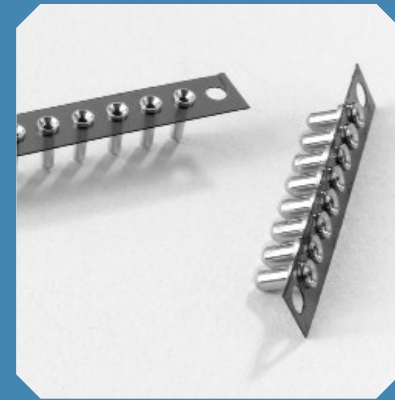
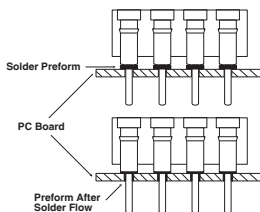

Surface Mount Applications:

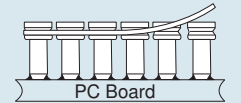

Peel-A-Way®
Surface Mount Sockets

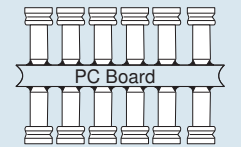

Surface Mount Top/Bottom

Features:

- Sockets surface mount to PCB.
- Supplied in high temperature Peel-A-Way® socket terminal carrier.
- Peel-A-Way® carrier can be left in place for added stability.
- High reliability screw-machined terminals with multiple finger beryllium copper contacts.
- Available with solder preforms.

Available Online:

- RoHS Qualification Test Report



5 Energy Way, West Warwick, RI 02893 USA
Tel: 800.424.9850 | 401.823.5200
Fax: 401.823.8723
info@advanced.com | www.advanced.com
Cat. 16 Rev. 2

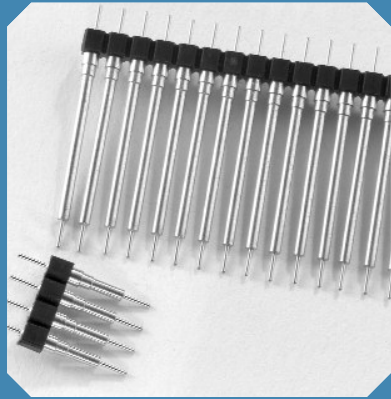

Table of Models

	<p>Description: Peel-A-Way® (KSA) Material: Polyimide Film Index: -269°C to 400°C (-452°F to 752°F)</p>	
	<p>Description: Molded Snap Strips (RSA) Material: High Temp. Liquid Crystal Polymer (LCP) Index: -40°C to 260°C (-40°F to 500°F)</p>	
	<p>Description: Molded Solid Strips (RNA) Material: High Temp. Liquid Crystal Polymer (LCP) Index: -40°C to 260°C (-40°F to 500°F)</p>	

RSA replaces SA, RNA replaces NA and HNA.

Features:

- Available in three body types: Peel-A-Way® Removable Terminal Carriers, molded Solid Strips, and molded Snap Strips [breakable at .100/(2.54mm)].
- Board to board applications.
- Peel-A-Way® Removable Terminal Carrier can be easily removed to allow inspection of solder joints on both sides of PC board, or left in place for added stability.
- Custom designs available.

Specifications:

Terminals:

Brass - Copper Alloy
(C36000) ASTM-B-16

Plating:

- G - Gold over Nickel
- M - Matte Tin over Nickel
- T - Tin/Lead over Nickel

Gold per MIL-G-45204
 Matte Tin per ASTM545-97
 Tin/Lead per MIL-P-81728
 Nickel per QQ-N-290

Dimensional Information

Molded Body Types

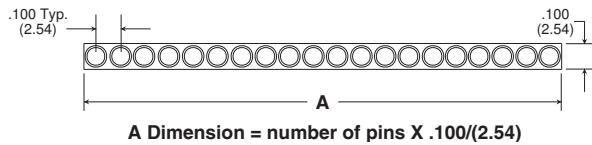

Peel-A-Way® Body Types

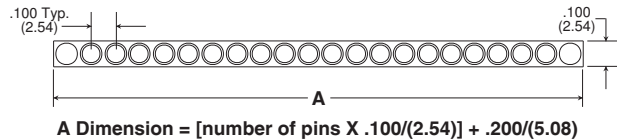

How To Order

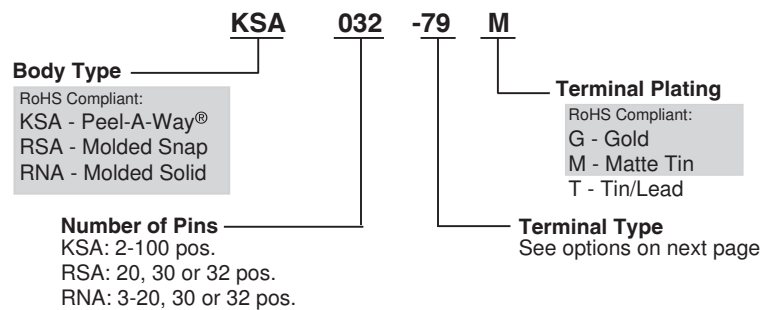

Note: Quick-Turn delivery is not available on products with Matte Tin plating.



5 Energy Way, West Warwick, RI 02893 USA
 Tel: 800.424.9850 | 401.823.5200
 Fax: 401.823.8723
 info@advanced.com | www.advanced.com
 Cat. 16 Rev. 2

Products shown covered by patents issued and/or pending. Specifications subject to change without notice.

inch/(mm)



Standard Quick-Turn Terminals

Additional standard and custom terminals available.
See Terminals section or consult factory.

Type -79	Type -80	Type -81	Type -574
Peel-A-Way® only	Peel-A-Way® only	Peel-A-Way® only	Peel-A-Way® only (not Quick-Turn)
Type -08	Type -09	Type -68	Type -43
Molded only	Molded only	Molded only	Molded only
Type -185	Type -42	Type -71	
Molded only	Molded only	Molded only	

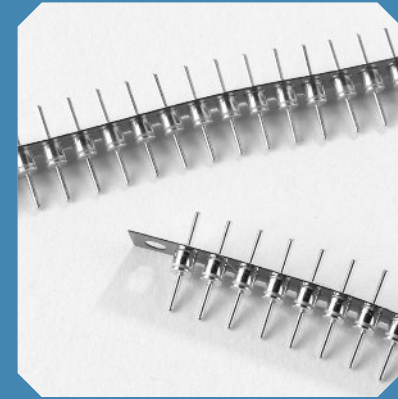

Surface Mount Applications:

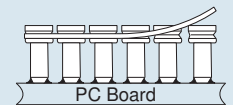

Peel-A-Way®
Surface Mount Sockets

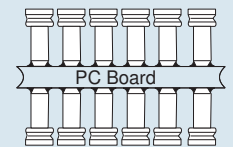

Surface Mount Top/Bottom

Features:

- Sockets surface mount to PCB.
- Supplied in high temperature Peel-A-Way® socket terminal carrier.
- Peel-A-Way® carrier can be left in place for added stability.
- High reliability screw-machined terminals with multiple finger beryllium copper contacts.
- Available with solder preforms.

Available Online:

- RoHS Qualification Test Report