

CD54/74HC4514, CD54/74HCT4514 CD54/74HC4515, CD54/74HCT4515

High-Speed CMOS Logic

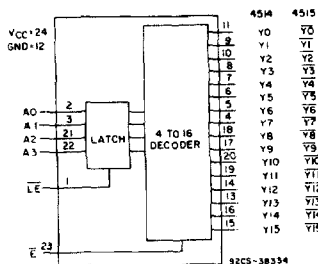

FUNCTIONAL DIAGRAM

4-to-16 Line Decoder/Demultiplexer with Input Latches

Type Features:

- Multifunction capability:
Binary to 1-of-16 decoder
1-to-16 line demultiplexer

The RCA CD54/74HC4514, 4515 and CD54/74HCT4514, 4515 are high-speed silicon gate devices consisting of a 4-bit strobed latch and a 4-to-16 line decoder. The selected output is enabled by a low on the enable input (E). A high on E inhibits selection of any output. Demultiplexing is accomplished by using the E input as the data input and the select inputs (A0-A3) as addresses. This E input also serves as a chip select when these devices are cascaded.

When Latch Enable (LE) is high the output follows changes in the inputs (see truth table). When LE is low the output is isolated from changes in the input and remains at the level (high for the 4514, low for the 4515) it had before the latches were enabled. These devices, enhanced versions of the equivalent CMOS types, can drive 10 LSTTL loads.

The CD54HC4514, 4515 and CD54HCT4514, 4515 are supplied in 24-lead dual-in-line frit-seal ceramic packages (F suffix). The CD74HC4514, 4515 and CD74HCT4514, are supplied in 24-lead dual-in-line, narrow-body plastic packages (EN suffix), in 24-lead dual-in-line, wide-body plastic packages (E suffix), and in 24-lead dual-in-line surface-mount plastic packages (M suffix). Both types are also available in chip form (H suffix).

Family Features

- Fanout (over temperature range):
Standard loads — 10 LSTTL loads
Bus driver outputs — 15 LSTTL loads
- Wide operating temperature range:
CD74HC/HCT: -40 to +85°C
- Balanced propagation delay and transition times
- Significant power reduction compared to LSTTL logic ICs
- Alternate source is Philips/Signetics
- CD54HC/CD74HC types:
2 to 6 V operation
High noise immunity: $N_{IL} = 30\%$, $N_{IH} = 30\%$;
@ $V_{CC} = 5V$
- CD54HCT/CD74HCT types:
4.5 to 5.5 V operation
Direct LSTTL input logic compatibility
 $V_{IL} = 0.8 V \text{ max.}$, $V_{IH} = 2 V \text{ min.}$
CMOS input compatibility
 $I_1 \leq 1 \mu A @ V_{OL}, V_{OH}$

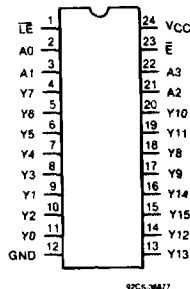

TERMINAL ASSIGNMENT

CD54/74HC4514, CD54/74HCT4514 CD54/74HC4515, CD54/74HCT4515

MAXIMUM RATINGS, Absolute-Maximum Values:

DC SUPPLY-VOLTAGE (V_{CC}):

(Voltages referenced to ground)	-0.5 to +7 V
DC INPUT DIODE CURRENT, I_{IK} (FOR $V_I < -0.5$ V OR $V_I > V_{CC} + 0.5$ V)	± 20 mA
DC OUTPUT CURRENT, I_{OK} (FOR $V_O < -0.5$ V OR $V_O > V_{CC} + 0.5$ V)	± 20 mA
DC DRAIN CURRENT, PER OUTPUT (I_O) (FOR -0.5 V $< V_O < V_{CC} + 0.5$ V)	± 25 mA
DC V_{CC} OR GROUND CURRENT, PER PIN (I_{CC})	± 50 mA

POWER DISSIPATION PER PACKAGE (P_D):

For $T_A = -40$ to $+60^\circ\text{C}$ (PACKAGE TYPE E)	500 mW
For $T_A = +60$ to -85°C (PACKAGE TYPE E)	Derate Linearly at 8 mW/ $^\circ\text{C}$ to 300 mW
For $T_A = -55$ to $+100^\circ\text{C}$ (PACKAGE TYPE F, H)	500 mW
For $T_A = +100$ to $+125^\circ\text{C}$ (PACKAGE TYPE F, H)	Derate Linearly at 8 mW/ $^\circ\text{C}$ to 300 mW
For $T_A = -40$ to $+70^\circ\text{C}$ (PACKAGE TYPE M)	400 mW
For $T_A = +70$ to $+125^\circ\text{C}$ (PACKAGE TYPE M)	Derate Linearly at 6 mW/ $^\circ\text{C}$ to 70 mW

OPERATING-TEMPERATURE RANGE (T_A):

PACKAGE TYPE F, H 	-55 to $+125^\circ\text{C}$
PACKAGE TYPE E, M	-40 to $+85^\circ\text{C}$

STORAGE TEMPERATURE (T_{STG})

-65 to $+150^\circ\text{C}$

LEAD TEMPERATURE (DURING SOLDERING):

At distance $1/16 \pm 1/32$ in. (1.59 ± 0.79 mm) from case for 10 s max.	$+265^\circ\text{C}$
Unit inserted into a PC Board (min. thickness $1/16$ in., 1.59 mm) with solder contacting lead tips only	$+300^\circ\text{C}$

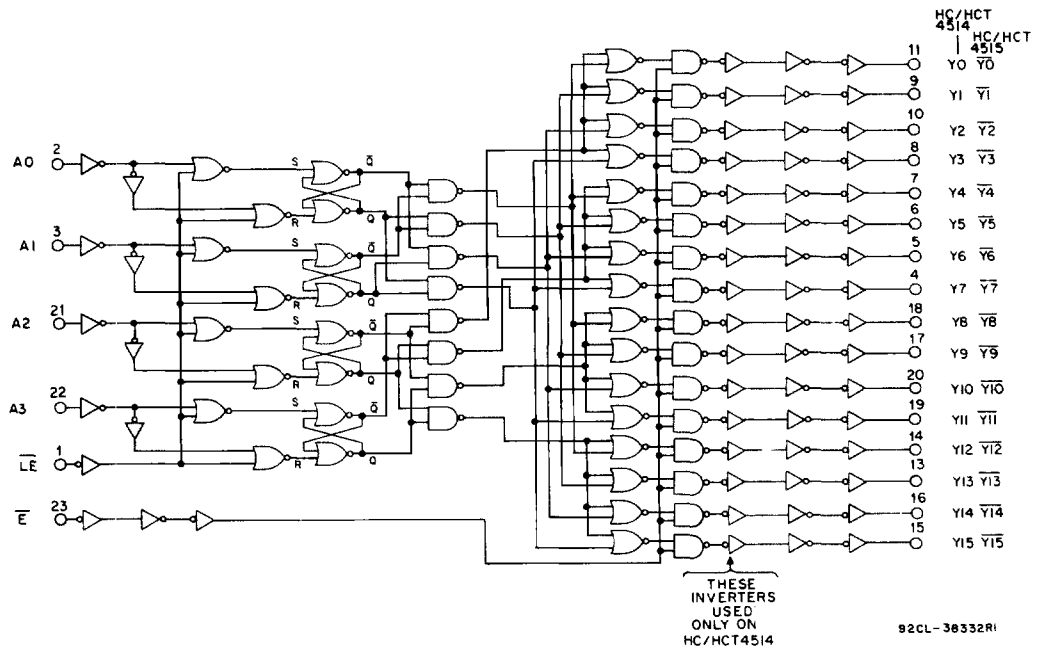

Fig. — Logic diagram for CD54/74HC4514, 4515 and CD54/74HCT4514, 4515.

CD54/74HC4514, CD54/74HCT4514 CD54/74HC4515, CD54/74HCT4515

DECODE TRUTH TABLE ($\bar{LE} = 1$)

ENABLE	DECODER INPUTS				ADDRESSED OUTPUT 4514 = Logic 1 (High) 4515 = Logic 0 (Low)
	A3	A2	A1	A0	
0	0	0	0	0	Y0
0	0	0	0	1	Y1
0	0	0	1	0	Y2
0	0	0	1	1	Y3
0	0	1	0	0	Y4
0	0	1	0	1	Y5
0	0	1	1	0	Y6
0	0	1	1	1	Y7
0	1	0	0	0	Y8
0	1	0	0	1	Y9
0	1	0	1	0	Y10
0	1	0	1	1	Y11
0	1	1	0	0	Y12
0	1	1	0	1	Y13
0	1	1	1	0	Y14
0	1	1	1	1	Y15
1	X	X	X	X	All Outputs = 0, 4514 All Outputs = 1, 4515

X = Don't Care Logic 1 = High Logic 0 = Low

RECOMMENDED OPERATING CONDITIONS:

For maximum reliability, nominal operating conditions should be selected so that operation is always within the following ranges:

CHARACTERISTIC	LIMITS		UNITS
	MIN.	MAX.	
Supply-Voltage Range (For T_A = Full Package Temperature Range) V_{CC} .* CD54/74HC Types	2	6	V
CD54/74HCT Types	4.5	5.5	V
DC Input or Output Voltage V_i, V_o	0	V_{CC}	V
Operating Temperature T_A : CD74 Types	-40	+85	°C
CD54 Types	-55	+125	°C
Input Rise and Fall Times, t_r, t_f at 2V	0	1000	ns
at 4.5 V	0	500	ns
at 6V	0	400	ns

*Unless otherwise specified, all voltages are referenced to Ground.

CD54/74HC4514, CD54/74HCT4514 CD54/74HC4515, CD54/74HCT4515

STATIC ELECTRICAL CHARACTERISTICS

CHARACTERISTIC	CD74HC4514/CD54HC4515										CD74HCT4514/CD54HCT4515								UNITS	
	TEST CONDITIONS			74HC/54HC TYPE			74HC TYPE		54HC TYPE		TEST CONDITIONS		74HCT/54HCT TYPE			74HCT TYPE		54HCT TYPE		
	V _i V	I _o mA	V _{cc} V	+25°C			-40/ +85°C		-55/ +125°C		V _i V	V _{cc} V	+25°C			-40/ +85°C		-55/ +125°C		
				Min	Typ	Max	Min	Max	Min	Max			Min	Typ	Max	Min	Max	Min		Max
High-Level Input Voltage V _{IH}			2	1.5	—	—	1.5	—	1.5	—	—	4.5	2	—	—	2	—	2	—	V
			4.5	3.15	—	—	3.15	—	3.15	—	I _o	5.5	—	—	—	—	—	—	—	
			6	4.2	—	—	4.2	—	4.2	—										
Low-Level Input Voltage V _{IL}			2	—	—	0.5	—	0.5	—	0.5	—	4.5	—	—	0.8	—	0.8	—	0.8	V
			4.5	—	—	1.35	—	1.35	—	1.35	—	I _o	5.5	—	—	—	—	—	—	
			6	—	—	1.8	—	1.8	—	1.8	—									
High-Level Output Voltage V _{OH}	V _{IL} or V _{IH}	-0.02	2	1.9	—	—	1.9	—	1.9	—	V _{IL} or V _{IH}	4.5	4.4	—	—	4.4	—	4.4	—	V
CMOS Loads			4.5	4.4	—	—	4.4	—	4.4	—										
			6	5.9	—	—	5.9	—	5.9	—										
TTL Loads	V _{IL} or V _{IH}	-4	4.5	3.98	—	—	3.84	—	3.7	—	V _{IL} or V _{IH}	4.5	3.98	—	—	3.84	—	3.7	—	V
			6	5.48	—	—	5.34	—	5.2	—										
Low-Level Output Voltage V _{OL}	V _{IL} or V _{IH}	0.02	2	—	—	0.1	—	0.1	—	0.1	V _{IL} or V _{IH}	4.5	—	—	0.1	—	0.1	—	0.1	V
CMOS Loads			4.5	—	—	0.1	—	0.1	—	0.1										
			6	—	—	0.1	—	0.1	—	0.1										
TTL Loads	V _{IL} or V _{IH}	4	4.5	—	—	0.26	—	0.33	—	0.4	V _{IL} or V _{IH}	4.5	—	—	0.26	—	0.33	—	0.4	V
			6	—	—	0.26	—	0.33	—	0.4										
Input Leakage Current I _i	V _{cc} or Gnd		6	—	—	±0.1	—	±1	—	±1	Any Voltage Between V _{cc} & Gnd	5.5	—	—	±0.1	—	±1	—	±1	μA
Quiescent Device Current I _{cc}	V _{cc} or Gnd	0	6	—	—	8	—	80	—	160	V _{cc} or Gnd	5.5	—	—	8	—	80	—	160	μA
Additional Quiescent Device Current per input pin; 1 unit load ΔI _{cc} *											V _{cc} - 2.1 4.5 to 5.5	—	100	360	—	450	—	490	μA	

*For dual-supply systems theoretical worst case (V_i = 2.4 V, V_{cc} = 5.5 V) specification is 1.8 mA.

HCT Input Loading Table

Input	Unit Loads*
A0 — A3	0.15
LE	0.85
E	0.3

*Unit load is ΔI_{cc} limit specified in Static Characteristic Chart, e.g., 360 μA max. @ 25°C.

CD54/74HC4514, CD54/74HCT4514 CD54/74HC4515, CD54/74HCT4515

SWITCHING CHARACTERISTICS ($V_{CC} = 5\text{ V}$, $T_A = 25^\circ\text{C}$, Input $t_r, t_f = 6\text{ ns}$)

CHARACTERISTIC	SYMBOL	C_L (pF)	Typical Values		UNITS
			HC	HCT	
Propagation Delay Select to Output	t_{PHL}	15	23	25	ns
	t_{PLH}				
\overline{LE} to Output	t_{PHL}	15	19	21	ns
	t_{PLH}				
\overline{E} to Output	t_{PHL}	15	14	17	ns
	t_{PLH}				
Power Dissipation Capacitance*	C_{PD}	—	70	75	pF

* C_{PD} is used to determine the dynamic power consumption, per package.

$PD = V_{CC}^2 f_i (C_{PD} + C_L)$ where:

f_i = input frequency,

C_L = output load capacitance

V_{CC} = supply voltage

PREREQUISITE FOR SWITCHING FUNCTION

CHARACTERISTIC	SYMBOL	V_{CC}	25°C				-40°C to +85°C				-55°C to +125°C				UNITS
			HC		HCT		74HC		74HCT		54HC		54HCT		
			Min.	Max.	Min.	Max.	Min.	Max.	Min.	Max.	Min.	Max.	Min.	Max.	
\overline{LE} Pulse Width	t_w	2	75	—	—	—	95	—	—	—	110	—	—	—	ns
		4.5	15	—	30	—	19	—	38	—	22	—	45	—	
		6	13	—	—	—	16	—	—	—	19	—	—	—	
Select to \overline{LE} Set-up time	t_{su}	2	100	—	—	—	125	—	—	—	150	—	—	—	ns
		4.5	20	—	20	—	25	—	25	—	30	—	30	—	
		6	17	—	—	—	21	—	—	—	26	—	—	—	
Select to \overline{LE} Hold Time	t_H	2	0	—	—	—	0	—	—	—	0	—	—	—	ns
		4.5	0	—	5	—	0	—	5	—	0	—	5	—	
		6	0	—	—	—	0	—	—	—	0	—	—	—	

SWITCHING CHARACTERISTICS ($C_L = 50\text{ pF}$, Input $t_r, t_f = 6\text{ ns}$)

CHARACTERISTIC	SYMBOL	V_{CC}	25°C				-40°C to +85°C				-55°C to +125°C				UNITS
			HC		HCT		74HC		74HCT		54HC		54HCT		
			Min.	Max.	Min.	Max.	Min.	Max.	Min.	Max.	Min.	Max.	Min.	Max.	
Propagation Delay Select to Outputs	t_{PLH} t_{PHL}	2	—	275	—	—	—	345	—	—	—	415	—	—	ns
		4.5	—	55	—	55	—	69	—	69	—	83	—	83	
		6	—	47	—	—	—	59	—	—	—	71	—	—	
\overline{LE} to Outputs	t_{PLH} t_{PHL}	2	—	225	—	—	—	280	—	—	—	340	—	—	ns
		4.5	—	45	—	50	—	56	—	63	—	68	—	75	
		6	—	38	—	—	—	48	—	—	—	58	—	—	
\overline{E} to Outputs	t_{PLH} t_{PHL}	2	—	175	—	—	—	220	—	—	—	265	—	—	ns
		4.5	—	35	—	40	—	44	—	50	—	53	—	60	
		6	—	30	—	—	—	37	—	—	—	45	—	—	
Output Transition Time	t_{TLH} t_{THL}	2	—	75	—	—	—	95	—	—	—	110	—	—	ns
		4.5	—	15	—	15	—	19	—	19	—	22	—	22	
		6	—	13	—	—	—	16	—	—	—	19	—	—	
Input Capacitance	C_i		—	10	—	10	—	10	—	10	—	10	—	pF	

CD54/74HC4514, CD54/74HCT4514 CD54/74HC4515, CD54/74HCT4515

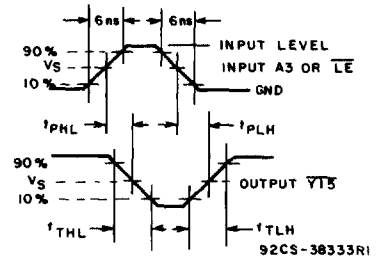
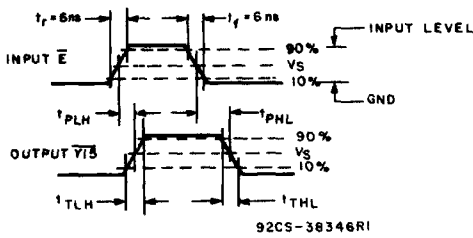

	54/74HC	54/74HCT
Input Level	V_{CC}	3 V
Switching Voltage, V_s	50% V_{CC}	1.3 V

Propagation delay times and transition times for HC/HCT4515.

