



---

# HM66AEB36102/HM66AEB18202

## HM66AEB9402

36-Mbit DDR II SRAM  
2-word Burst

REJ03C0046-0001Z  
(Previous ADE-203-1365 (Z) Rev. 0.0)  
Preliminary  
Rev.0.01  
Apr.28.2004

---

### Description

The HM66AEB36102 is a 1,048,576-word by 36-bit, the HM66AEB18202 is a 2,097,152-word by 18-bit, and the HM66AEB9402 is a 4,194,304-word by 9-bit synchronous double data rate static RAM fabricated with advanced CMOS technology using full CMOS six-transistor memory cell. It integrates unique synchronous peripheral circuitry and a burst counter. All input registers controlled by an input clock pair (K and  $\bar{K}$ ) and are latched on the positive edge of K and  $\bar{K}$ . These products are suitable for applications which require synchronous operation, high speed, low voltage, high density and wide bit configuration. These products are packaged in 165-pin plastic FBGA package.

Preliminary: The specifications of this device are subject to change without notice. Please contact your nearest Renesas Technology's Sales Dept. regarding specifications.

## Features

- 1.8 V  $\pm$  0.1 V power supply for core ( $V_{DD}$ )
- 1.4 V to  $V_{DD}$  power supply for I/O ( $V_{DDQ}$ )
- DLL circuitry for wide output data valid window and future frequency scaling
- Pipelined double data rate operation
- Common data input/output bus
- Two-tick burst for low DDR transaction size
- Two input clocks (K and  $\bar{K}$ ) for precise DDR timing at clock rising edges only
- Two output clocks (C and  $\bar{C}$ ) for precise flight time and clock skew matching-clock and data delivered together to receiving device
- Internally self-timed write control
- Clock-stop capability with  $\mu$ s restart
- User programmable impedance output
- Fast clock cycle time: 3.0 ns (333 MHz)/3.3 ns (300 MHz)/4.0 ns (250 MHz)/5.0 ns (200 MHz)/6.0 ns (167 MHz)
- Simple control logic for easy depth expansion
- JTAG boundary scan

## Ordering Information

Type No.	Organization	Cycle time	Clock frequency	Package
HM66AEB36102BP-30	1-M word	3.0 ns	333 MHz	Plastic FBGA 165-pin (BP-165A)
HM66AEB36102BP-33	$\times$ 36-bit	3.3 ns	300 MHz	
HM66AEB36102BP-40		4.0 ns	250 MHz	
HM66AEB36102BP-50		5.0 ns	200 MHz	
HM66AEB36102BP-60		6.0 ns	167 MHz	
HM66AEB18202BP-30	2-M word	3.0 ns	333 MHz	
HM66AEB18202BP-33	$\times$ 18-bit	3.3 ns	300 MHz	
HM66AEB18202BP-40		4.0 ns	250 MHz	
HM66AEB18202BP-50		5.0 ns	200 MHz	
HM66AEB18202BP-60		6.0 ns	167 MHz	
HM66AEB9402BP-30	4-M word	3.0 ns	333 MHz	
HM66AEB9402BP-33	$\times$ 9-bit	3.3 ns	300 MHz	
HM66AEB9402BP-40		4.0 ns	250 MHz	
HM66AEB9402BP-50		5.0 ns	200 MHz	
HM66AEB9402BP-60		6.0 ns	167 MHz	

**Pin Arrangement (HM66AEB36102) 165PIN-BGA**

	1	2	3	4	5	6	7	8	9	10	11
A	$\overline{\text{CQ}}$	$V_{SS}$	SA	$\text{R}/\overline{\text{W}}$	$\overline{\text{BW2}}$	$\overline{\text{K}}$	$\overline{\text{BW1}}$	$\overline{\text{LD}}$	SA	NC	CQ
B	NC	DQ27	DQ18	SA	$\overline{\text{BW3}}$	K	$\overline{\text{BW0}}$	SA	NC	NC	DQ8
C	NC	NC	DQ28	$V_{SS}$	SA	SA0	SA	$V_{SS}$	NC	DQ17	DQ7
D	NC	DQ29	DQ19	$V_{SS}$	$V_{SS}$	$V_{SS}$	$V_{SS}$	$V_{SS}$	NC	NC	DQ16
E	NC	NC	DQ20	$V_{DDQ}$	$V_{SS}$	$V_{SS}$	$V_{SS}$	$V_{DDQ}$	NC	DQ15	DQ6
F	NC	DQ30	DQ21	$V_{DDQ}$	$V_{DD}$	$V_{SS}$	$V_{DD}$	$V_{DDQ}$	NC	NC	DQ5
G	NC	DQ31	DQ22	$V_{DDQ}$	$V_{DD}$	$V_{SS}$	$V_{DD}$	$V_{DDQ}$	NC	NC	DQ14
H	$\overline{\text{DOFF}}$	$V_{REF}$	$V_{DDQ}$	$V_{DDQ}$	$V_{DD}$	$V_{SS}$	$V_{DD}$	$V_{DDQ}$	$V_{DDQ}$	$V_{REF}$	ZQ
J	NC	NC	DQ32	$V_{DDQ}$	$V_{DD}$	$V_{SS}$	$V_{DD}$	$V_{DDQ}$	NC	DQ13	DQ4
K	NC	NC	DQ23	$V_{DDQ}$	$V_{DD}$	$V_{SS}$	$V_{DD}$	$V_{DDQ}$	NC	DQ12	DQ3
L	NC	DQ33	DQ24	$V_{DDQ}$	$V_{SS}$	$V_{SS}$	$V_{SS}$	$V_{DDQ}$	NC	NC	DQ2
M	NC	NC	DQ34	$V_{SS}$	$V_{SS}$	$V_{SS}$	$V_{SS}$	$V_{SS}$	NC	DQ11	DQ1
N	NC	DQ35	DQ25	$V_{SS}$	SA	SA	SA	$V_{SS}$	NC	NC	DQ10
P	NC	NC	DQ26	SA	SA	C	SA	SA	NC	DQ9	DQ0
R	TDO	TCK	SA	SA	SA	$\overline{\text{C}}$	SA	SA	SA	TMS	TDI

(Top view)

**Pin Arrangement (HM66AEB18202) 165PIN-BGA**

	1	2	3	4	5	6	7	8	9	10	11
A	$\overline{\text{CQ}}$	$V_{SS}$	SA	$\text{R}/\overline{\text{W}}$	$\overline{\text{BW1}}$	$\overline{\text{K}}$	NC	$\overline{\text{LD}}$	SA	SA	CQ
B	NC	DQ9	NC	SA	NC	K	$\overline{\text{BW0}}$	SA	NC	NC	DQ8
C	NC	NC	NC	$V_{SS}$	SA	SA0	SA	$V_{SS}$	NC	DQ7	NC
D	NC	NC	DQ10	$V_{SS}$	$V_{SS}$	$V_{SS}$	$V_{SS}$	$V_{SS}$	NC	NC	NC
E	NC	NC	DQ11	$V_{DDQ}$	$V_{SS}$	$V_{SS}$	$V_{SS}$	$V_{DDQ}$	NC	NC	DQ6
F	NC	DQ12	NC	$V_{DDQ}$	$V_{DD}$	$V_{SS}$	$V_{DD}$	$V_{DDQ}$	NC	NC	DQ5
G	NC	NC	DQ13	$V_{DDQ}$	$V_{DD}$	$V_{SS}$	$V_{DD}$	$V_{DDQ}$	NC	NC	NC
H	$\overline{\text{DOFF}}$	$V_{REF}$	$V_{DDQ}$	$V_{DDQ}$	$V_{DD}$	$V_{SS}$	$V_{DD}$	$V_{DDQ}$	$V_{DDQ}$	$V_{REF}$	ZQ
J	NC	NC	NC	$V_{DDQ}$	$V_{DD}$	$V_{SS}$	$V_{DD}$	$V_{DDQ}$	NC	DQ4	NC
K	NC	NC	DQ14	$V_{DDQ}$	$V_{DD}$	$V_{SS}$	$V_{DD}$	$V_{DDQ}$	NC	NC	DQ3
L	NC	DQ15	NC	$V_{DDQ}$	$V_{SS}$	$V_{SS}$	$V_{SS}$	$V_{DDQ}$	NC	NC	DQ2
M	NC	NC	NC	$V_{SS}$	$V_{SS}$	$V_{SS}$	$V_{SS}$	$V_{SS}$	NC	DQ1	NC
N	NC	NC	DQ16	$V_{SS}$	SA	SA	SA	$V_{SS}$	NC	NC	NC
P	NC	NC	DQ17	SA	SA	C	SA	SA	NC	NC	DQ0
R	TDO	TCK	SA	SA	SA	$\overline{\text{C}}$	SA	SA	SA	TMS	TDI

(Top view)

**Pin Arrangement (HM66AEB9402) 165PIN-BGA**

	1	2	3	4	5	6	7	8	9	10	11
A	$\overline{\text{CQ}}$	$V_{SS}$	SA	$\overline{\text{R/W}}$	NC	$\overline{\text{K}}$	NC	$\overline{\text{LD}}$	SA	SA	CQ
B	NC	NC	NC	SA	NC	K	$\overline{\text{BW}}$	SA	NC	NC	DQ4
C	NC	NC	NC	$V_{SS}$	SA	SA	SA	$V_{SS}$	NC	NC	NC
D	NC	NC	NC	$V_{SS}$	$V_{SS}$	$V_{SS}$	$V_{SS}$	$V_{SS}$	NC	NC	NC
E	NC	NC	DQ5	$V_{DDQ}$	$V_{SS}$	$V_{SS}$	$V_{SS}$	$V_{DDQ}$	NC	NC	DQ3
F	NC	NC	NC	$V_{DDQ}$	$V_{DD}$	$V_{SS}$	$V_{DD}$	$V_{DDQ}$	NC	NC	NC
G	NC	NC	DQ6	$V_{DDQ}$	$V_{DD}$	$V_{SS}$	$V_{DD}$	$V_{DDQ}$	NC	NC	NC
H	$\overline{\text{DOFF}}$	$V_{REF}$	$V_{DDQ}$	$V_{DDQ}$	$V_{DD}$	$V_{SS}$	$V_{DD}$	$V_{DDQ}$	$V_{DDQ}$	$V_{REF}$	ZQ
J	NC	NC	NC	$V_{DDQ}$	$V_{DD}$	$V_{SS}$	$V_{DD}$	$V_{DDQ}$	NC	DQ2	NC
K	NC	NC	NC	$V_{DDQ}$	$V_{DD}$	$V_{SS}$	$V_{DD}$	$V_{DDQ}$	NC	NC	NC
L	NC	DQ7	NC	$V_{DDQ}$	$V_{SS}$	$V_{SS}$	$V_{SS}$	$V_{DDQ}$	NC	NC	DQ1
M	NC	NC	NC	$V_{SS}$	$V_{SS}$	$V_{SS}$	$V_{SS}$	$V_{SS}$	NC	NC	NC
N	NC	NC	NC	$V_{SS}$	SA	SA	SA	$V_{SS}$	NC	NC	NC
P	NC	NC	DQ8	SA	SA	C	SA	SA	NC	NC	DQ0
R	TDO	TCK	SA	SA	SA	$\overline{\text{C}}$	SA	SA	SA	TMS	TDI

(Top view)

Note: Note that 6C is not SA0. The ×9 product does not permit random start address on the least significant address bit. SA0 = 0 at the start of each address.

**Notes on Usage**

- Power-on initialization cycles are required for all operations, including JTAG functions, to become normal.
- Clock recovery initialization cycles are required for read/write operations to become normal.
- Output buffer impedance can be programmed by terminating the ZQ ball to  $V_{SS}$  through a precision resistor (RQ). The value of RQ is five times the output impedance desired. The allowable range of RQ to guarantee impedance matching with a tolerance of 10% is 250 Ω typical. The total external capacitance of ZQ ball must be less than 7.5 pF.

## Pin Descriptions

Name	I/O type	Descriptions
SA0 SA	Input	Synchronous address inputs: These inputs are registered and must meet the setup and hold times around the rising edge of K. All transactions operate on a burst-of-two words (one clock period of bus activity). SA0 is used as the lowest address bit for burst READ and burst WRITE operations permitting a random burst start address on $\times 18$ and $\times 36$ devices. These inputs are ignored when device is deselected.
$\overline{\text{LD}}$	Input	Synchronous load: This input is brought low when a bus cycle sequence is to be defined. This definition includes address and READ / WRITE direction. All transactions operate on a burst-of-two data (one clock period of bus activity).
$\overline{\text{R/W}}$	Input	Synchronous read / write input: When $\overline{\text{LD}}$ is low, this input designates the access type (READ when $\overline{\text{R/W}}$ is high, WRITE when $\overline{\text{R/W}}$ is low) for the loaded address. $\overline{\text{R/W}}$ must meet the setup and hold times around the rising edge of K.
$\overline{\text{BW}}$ $\overline{\text{Bwn}}$	Input	Synchronous byte writes: When low, these inputs cause their respective byte to be registered and written during WRITE cycles. These signals must meet setup and hold times around the rising edges of K and $\overline{\text{K}}$ for each of the two rising edges comprising the WRITE cycle. See Byte Write Truth Table for signal to data relationship.
K, $\overline{\text{K}}$	Input	Input clock: This input clock pair registers address and control inputs on the rising edge of K, and registers data on the rising edge of K and the rising edge of $\overline{\text{K}}$ . $\overline{\text{K}}$ is ideally 180 degrees out of phase with K. All synchronous inputs must meet setup and hold times around the clock rising edges. These balls cannot remain $V_{\text{REF}}$ level.
C, $\overline{\text{C}}$	Input	Output clock: This clock pair provides a user-controlled means of tuning device output data. The rising edge of $\overline{\text{C}}$ is used as the output timing reference for first output data. The rising edge of C is used as the output timing reference for second output data. Ideally, $\overline{\text{C}}$ is 180 degrees out of phase with C. C and $\overline{\text{C}}$ may be tied high to force the use of K and $\overline{\text{K}}$ as the output reference clocks instead of having to provide C and $\overline{\text{C}}$ clocks. If tied high, C and $\overline{\text{C}}$ must remain high and not to be toggled during device operation. These balls cannot remain $V_{\text{REF}}$ level.
$\overline{\text{DOFF}}$	Input	DLL disable: When low, this input causes the DLL to be bypassed for stable, low frequency operation.
ZQ	Input	Output impedance matching input: This input is used to tune the device outputs to the system data bus impedance. DQ and CQ output impedance are set to $0.2 \times \text{RQ}$ , where RQ is a resistor from this ball to ground. This ball can be connected directly to $V_{\text{DDQ}}$ , which enables the minimum impedance mode. This ball cannot be connected directly to $V_{\text{SS}}$ or left unconnected.
TMS TDI	Input	IEEE1149.1 test inputs: 1.8 V I/O levels. These balls may be left not connected if the JTAG function is not used in the circuit.
TCK	Input	IEEE1149.1 clock input: 1.8 V I/O levels. This ball must be tied to $V_{\text{SS}}$ if the JTAG function is not used in the circuit.

## HM66AEB36102/18202/9402

---

Name	I/O type	Descriptions
DQ0 to DQn	Input/output	Synchronous data I/Os: Input data must meet setup and hold times around the rising edges of K and $\bar{K}$ . Output data is synchronized to the respective C and $\bar{C}$ , or to the respective K and $\bar{K}$ if C and $\bar{C}$ are tied high. The ×9 device uses DQ0 to DQ8. Remaining signals are NC. The ×18 device uses DQ0 to DQ17. Remaining signals are NC. The ×36 device uses DQ0 to DQ35.
CQ, $\bar{CQ}$	Output	Synchronous echo clock outputs: The edges of these outputs are tightly matched to the synchronous data outputs and can be used as a data valid indication. These signals run freely and do not stop when DQ tri-states.
TDO	Output	IEEE 1149.1 test output: 1.8 V I/O level.
V <sub>DD</sub>	Supply	Power supply: 1.8 V nominal. See DC Characteristics and Operating Conditions for range.
V <sub>DDQ</sub>	Supply	Power supply: Isolated output buffer supply. Nominally 1.5 V. 1.8 V is also permissible. See DC Characteristics and Operating Conditions for range.
V <sub>SS</sub>	Supply	Power supply: Ground
V <sub>REF</sub>	—	HSTL input reference voltage: Nominally V <sub>DDQ</sub> /2, but may be adjusted to improve system noise margin. Provides a reference voltage for the HSTL input buffers.
NC	—	No connect: These signals are internally connected. These signals may be connected to ground to improve package heat dissipation.

Note: 1. All power supply and ground balls must be connected for proper operation of the device.

**Block Diagram (HM66AEB36102)**

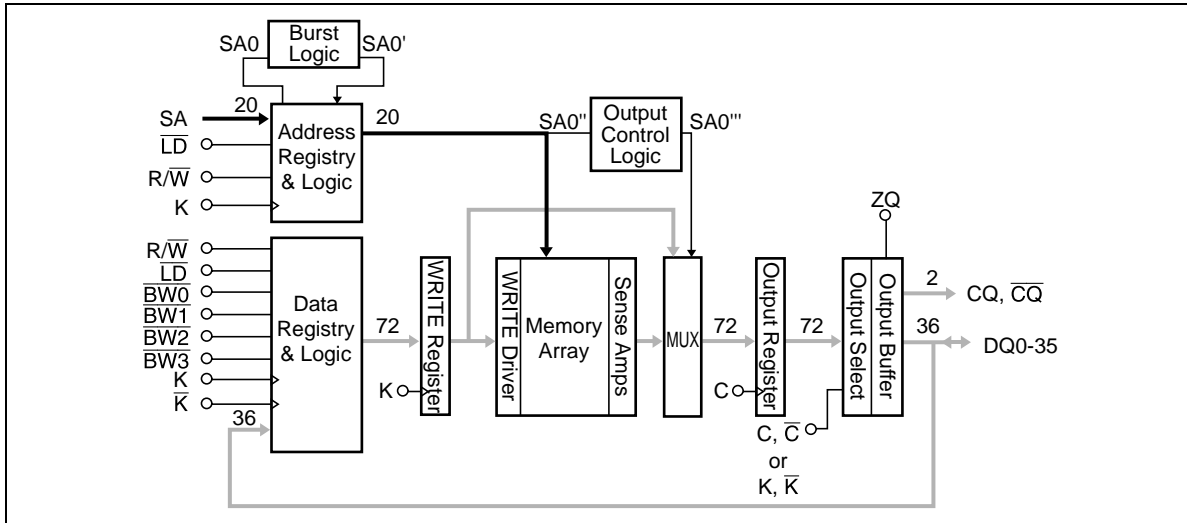

**Block Diagram (HM66AEB18202)**

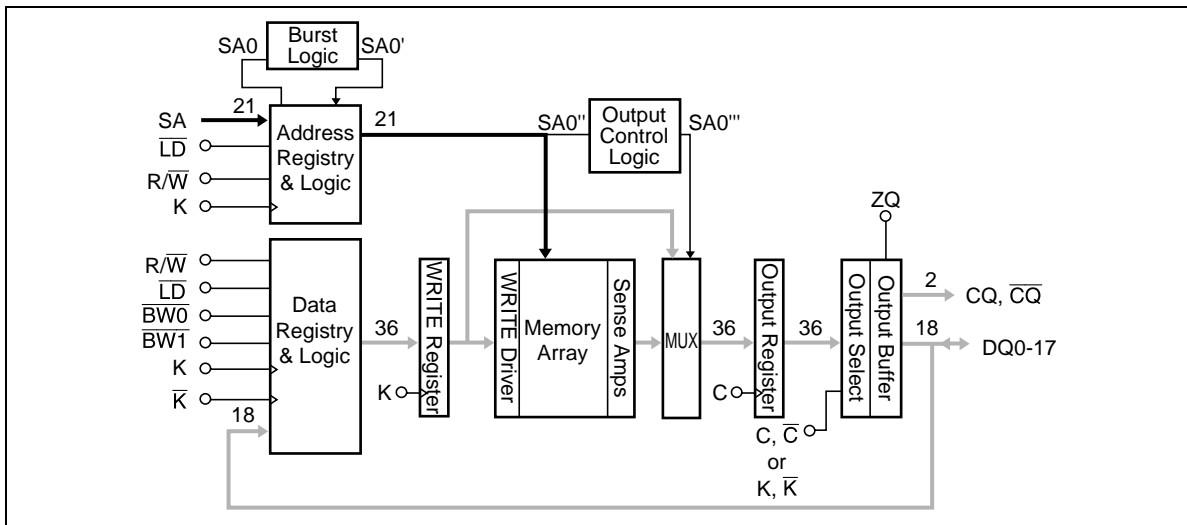

Block Diagram (HM66AEB9402)

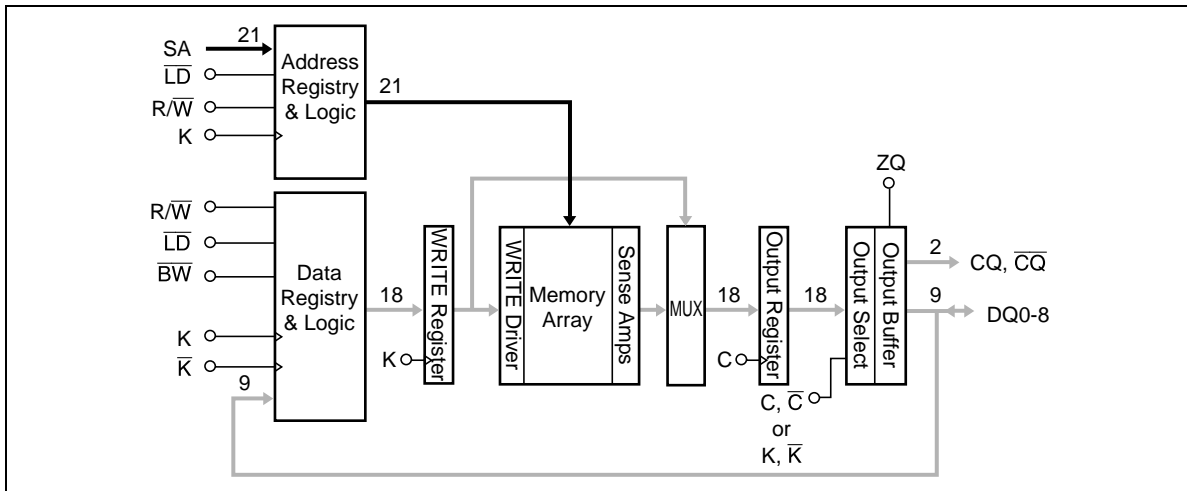



## Burst Sequence

### Linear Burst Sequence Table

(HM66AEB36102/18202)

	SA0	SA0
External address	0	1
1st internal burst address	1	0

### Truth Table

Operation	K	$\overline{LD}$	$R/\overline{W}$	DQ
WRITE cycle	L→H	L	L	Data in
Load address, input write data on consecutive K and $\overline{K}$ rising edges				Input data
				D(A1)    D(A2)
				Input clock
				K(t+1)↑ $\overline{K}(t+1)$ ↑
READ cycle	L→H	L	H	Data out
Load address, read data on consecutive C and $\overline{C}$ rising edges				Output data
				Q(A1)    Q(A2)
				Output clock
				$\overline{C}(t+1)$ ↑    C(t+2)↑
NOP (No operation)	L→H	H	×	High-Z
STANDBY (Clock stopped)	Stopped	×	×	Previous state

- Notes:
1. H: high level, L: low level, ×: don't care, ↑: rising edge.
  2. Data inputs are registered at K and  $\overline{K}$  rising edges. Data outputs are delivered at C and  $\overline{C}$  rising edges, except if C and  $\overline{C}$  are high, then data outputs are delivered at K and  $\overline{K}$  rising edges.
  3.  $\overline{LD}$  and  $R/\overline{W}$  must meet setup/hold times around the rising edges (low to high) of K and are registered at the rising edge of K.
  4. This device contains circuitry that will ensure the outputs will be in high-Z during power-up.
  5. Refer to state diagram and timing diagrams for clarification.
  6. When clocks are stopped, the following cases are recommended; the case of K = low,  $\overline{K}$  = high, C = low and  $\overline{C}$  = high, or the case of K = high,  $\overline{K}$  = low, C = high and  $\overline{C}$  = low. This condition is not essential, but permits most rapid restart by overcoming transmission line charging symmetrically.
  7. A1 refers to the address input during a WRITE or READ cycle. A2 refers to the next internal burst address in accordance with the linear burst sequence.

## Byte Write Truth Table

(HM66AEB36102)

Operation	K	$\bar{K}$	$\overline{BW0}$	$\overline{BW1}$	$\overline{BW2}$	$\overline{BW3}$
Write D0 to D35	L→H	—	L	L	L	L
	—	L→H	L	L	L	L
Write D0 to D8	L→H	—	L	H	H	H
	—	L→H	L	H	H	H
Write D9 to D17	L→H	—	H	L	H	H
	—	L→H	H	L	H	H
Write D18 to D26	L→H	—	H	H	L	H
	—	L→H	H	H	L	H
Write D27 to D35	L→H	—	H	H	H	L
	—	L→H	H	H	H	L
Write nothing	L→H	—	H	H	H	H
	—	L→H	H	H	H	H

Notes: 1. H: high level, L: low level, →: rising edge.

2. Assumes a WRITE cycle was initiated.  $\overline{BW0}$  to  $\overline{BW3}$  can be altered for any portion of the BURST WRITE operation provided that the setup and hold requirements are satisfied.

(HM66AEB18202)

Operation	K	$\bar{K}$	$\overline{BW0}$	$\overline{BW1}$
Write D0 to D17	L→H	—	L	L
	—	L→H	L	L
Write D0 to D8	L→H	—	L	H
	—	L→H	L	H
Write D9 to D17	L→H	—	H	L
	—	L→H	H	L
Write nothing	L→H	—	H	H
	—	L→H	H	H

Notes: 1. H: high level, L: low level, →: rising edge.

2. Assumes a WRITE cycle was initiated.  $\overline{BW0}$  and  $\overline{BW1}$  can be altered for any portion of the BURST WRITE operation provided that the setup and hold requirements are satisfied.

## HM66AEB36102/18202/9402

(HM66AEB9402)

Operation	K	$\bar{K}$	$\bar{B}\bar{W}$
Write D0 to D8	L→H	—	L
	—	L→H	L
Write nothing	L→H	—	H
	—	L→H	H

Notes: 1. H: high level, L: low level, →: rising edge.

2. Assumes a WRITE cycle was initiated.  $\bar{B}\bar{W}$  can be altered for any portion of the BURST WRITE operation provided that the setup and hold requirements are satisfied.

### Bus Cycle State Diagram

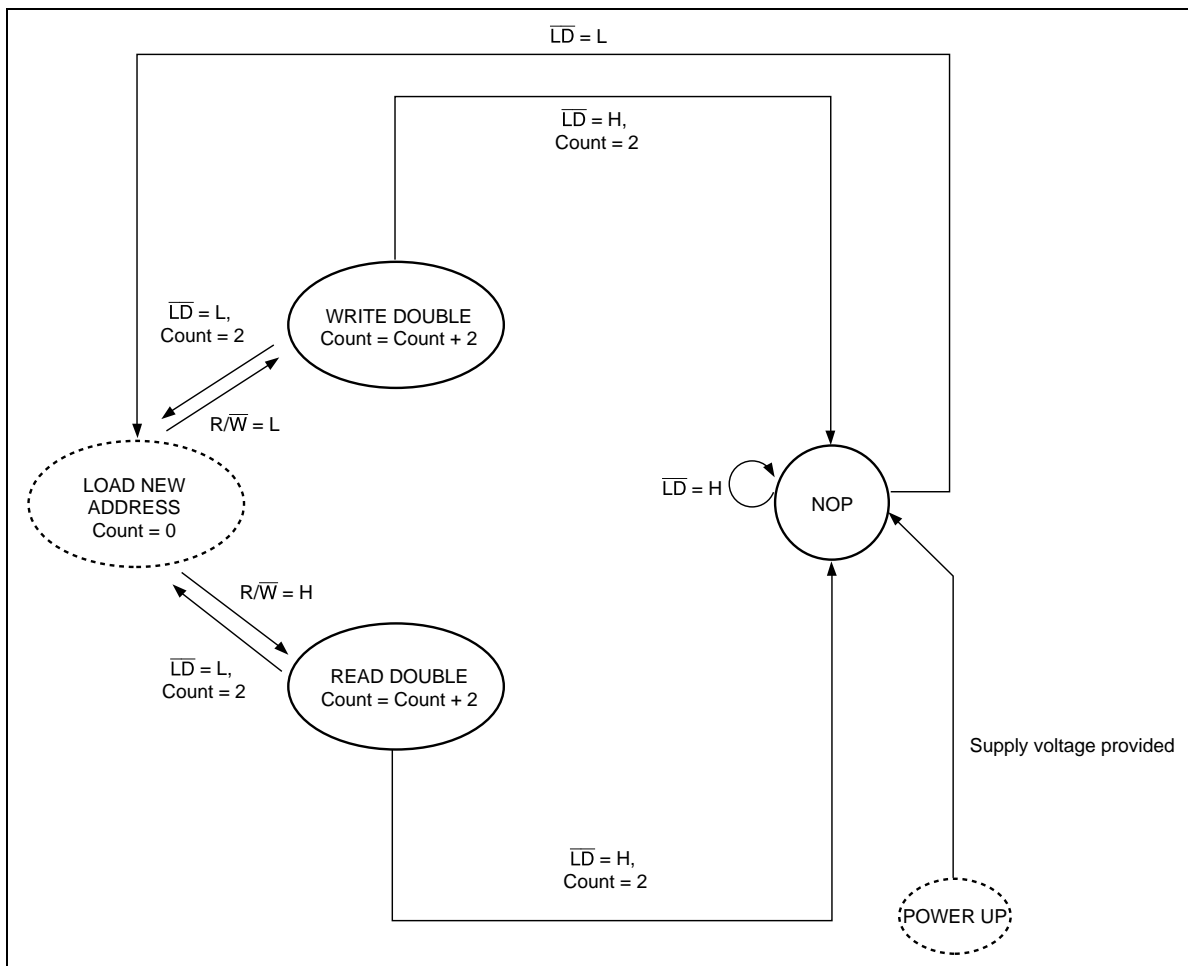

Notes: 1. SA0 is internally advanced in accordance with the burst order table. Bus cycle is terminated at the end of this sequence (burst count = 2).

2. State machine control timing sequence is controlled by K.

## Absolute Maximum Ratings

Parameter	Symbol	Rating	Unit	Notes
Input voltage on any ball	$V_{IN}$	-0.5 to $V_{DD} + 0.5$ (2.5 V max.)	V	1, 4
Input/output voltage	$V_{IO}$	-0.5 to $V_{DDQ} + 0.5$ (2.5 V max.)	V	1, 4
Core supply voltage	$V_{DD}$	-0.5 to 2.5	V	1, 4
Output supply voltage	$V_{DDQ}$	-0.5 to $V_{DD}$	V	1, 4
Junction temperature	$T_j$	+125 (max)	°C	
Storage temperature	$T_{STG}$	-55 to +125	°C	

- Notes:
- All voltage is referenced to  $V_{SS}$ .
  - Permanent device damage may occur if Absolute Maximum Ratings are exceeded. Functional operation should be restricted the Operation Conditions. Exposure to higher than recommended voltages for extended periods of time could affect device reliability.
  - These CMOS memory circuits have been designed to meet the DC and AC specifications shown in the tables after thermal equilibrium has been established.
  - The following supply voltage application sequence is recommended:  $V_{SS}$ ,  $V_{DD}$ ,  $V_{DDQ}$ ,  $V_{REF}$  then  $V_{IN}$ . Remember, according to the Absolute Maximum Ratings table,  $V_{DDQ}$  is not to exceed 2.5 V, whatever the instantaneous value of  $V_{DDQ}$ .

## Recommended DC Operating Conditions ( $T_a = 0$ to $+70^\circ\text{C}$ )

Parameter	Symbol	Min	Typ	Max	Unit	Notes
Power supply voltage -- core	$V_{DD}$	1.7	1.8	1.9	V	
Power supply voltage -- I/O	$V_{DDQ}$	1.4	1.5	$V_{DD}$	V	
Input reference voltage -- I/O	$V_{REF}$	0.68	0.75	0.95	V	1
Input high voltage	$V_{IH(DC)}$	$V_{REF} + 0.1$	—	$V_{DDQ} + 0.3$	V	2, 3
Input low voltage	$V_{IL(DC)}$	-0.3	—	$V_{REF} - 0.1$	V	2, 3

- Notes:
- Peak to peak AC component superimposed on  $V_{REF}$  may not exceed 5% of  $V_{REF}$ .
  - Overshoot:  $V_{IH(AC)} \leq V_{DDQ} + 0.5$  V for  $t \leq t_{KHKH}/2$   
 Undershoot:  $V_{IL(AC)} \geq -0.5$  V for  $t \leq t_{KHKH}/2$   
 Power-up:  $V_{IH} \leq V_{DDQ} + 0.3$  V and  $V_{DD} \leq 1.7$  V and  $V_{DDQ} \leq 1.4$  V for  $t \leq 200$  ms  
 During normal operation,  $V_{DDQ}$  must not exceed  $V_{DD}$ .  
 Control input signals may not have pulse widths less than  $t_{KHKL}$  (min) or operate at cycle rates less than  $t_{KHKH}$  (min).
  - These are DC test criteria. The AC  $V_{IH} / V_{IL}$  levels are defined separately to measure timing parameters.

**DC Characteristics** ( $T_a = 0$  to  $+70^\circ\text{C}$ ,  $V_{DD} = 1.8\text{ V} \pm 0.1\text{ V}$ )

		HM66AEB36102/HM66AEB18202 HM66AEB9402							
			-30	-33	-40	-50	-60		
Parameter	Symbol	Max						Unit	Notes
Operating supply current (READ / WRITE)	( $\times 9 / \times 18$ )	$I_{DD}$	770	720	630	540	480	mA	1, 2, 3
	( $\times 36$ )	$I_{DD}$	880	800	700	600	520	mA	1, 2, 3
Standby supply current (NOP)	( $\times 9 / \times 18 / \times 36$ )	$I_{SB1}$	350	330	300	280	260	mA	2, 4, 5

Parameter	Symbol	Min	Max	Unit	Test conditions	Notes
Input leakage current	$I_{LI}$	-2	2	$\mu\text{A}$		10
Output leakage current	$I_{LO}$	-2	2	$\mu\text{A}$		11
Output high voltage (Low)	$V_{OH}$	$V_{DDQ} - 0.2$	$V_{DDQ}$	V	$ I_{OH}  \leq 0.1\text{ mA}$	8, 9
	$V_{OH}$	$V_{DDQ}/2 - 0.08$	$V_{DDQ}/2 + 0.08$	V	Notes6	8, 9
Output low voltage (Low)	$V_{OL}$	$V_{SS}$	0.2	V	$I_{OL} \leq 0.1\text{ mA}$	8, 9
	$V_{OL}$	$V_{DDQ}/2 - 0.08$	$V_{DDQ}/2 + 0.08$	V	Notes7	8, 9

- Notes:
1. All inputs (except ZQ,  $V_{REF}$ ) are held at either  $V_{IH}$  or  $V_{IL}$ .
  2.  $I_{OUT} = 0\text{ mA}$ .  $V_{DD} = V_{DD}\text{ max}$ ,  $t_{KHKH} = t_{KHKH}\text{ min}$ .
  3. Operating supply currents are measured at 100% bus utilization.
  4. All address / data inputs are static at either  $V_{IN} > V_{IH}$  or  $V_{IN} < V_{IL}$ .
  5. NOP currents are valid when entering NOP after all pending READ and WRITE cycles are completed.
  6. Outputs are impedance-controlled.  $|I_{OH}| = (V_{DDQ}/2)/(RQ/5)$  for values of  $175\ \Omega \leq RQ \leq 350\ \Omega$ .
  7. Outputs are impedance-controlled.  $I_{OL} = (V_{DDQ}/2)/(RQ/5)$  for values of  $175\ \Omega \leq RQ \leq 350\ \Omega$ .
  8. AC load current is higher than the shown DC values. AC I/O curves are available upon request.
  9. HSTL outputs meet JEDEC HSTL Class I and Class II standards.
  10.  $0 \leq V_{IN} \leq V_{DDQ}$  for all input balls (except  $V_{REF}$ , ZQ, TCK, TMS, TDI ball).
  11.  $0 \leq V_{OUT} \leq V_{DDQ}$  (except TDO ball), output disabled.

**Capacitance** ( $T_a = +25^\circ\text{C}$ ,  $f = 1.0\text{ MHz}$ ,  $V_{DD} = 1.8\text{ V}$ ,  $V_{DDQ} = 1.5\text{ V}$ )

Parameter	Symbol	Min	Typ	Max	Unit	Test conditions
Input capacitance	$C_{IN}$	—	4	5	pF	$V_{IN} = 0\text{ V}$
Clock input capacitance	$C_{CLK}$	—	5	6	pF	$V_{CLK} = 0\text{ V}$
Input/output capacitance (DQ, ZQ)	$C_{I/O}$	—	6	7	pF	$V_{I/O} = 0\text{ V}$

Notes: 1. These parameters are sampled and not 100% tested.  
 2. Except JTAG (TCK, TMS, TDI, TDO) pins.

**AC Characteristics** ( $T_a = 0\text{ to }+70^\circ\text{C}$ ,  $V_{DD} = 1.8\text{ V} \pm 0.1\text{ V}$ )

**Test Conditions**

Input waveform (Rise/fall time  $\leq 0.3\text{ ns}$ )

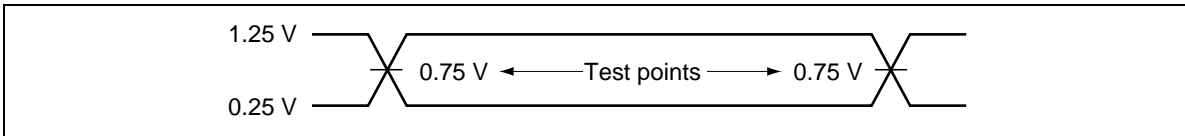

Output waveform

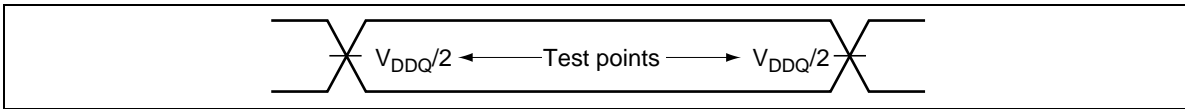

Output load condition

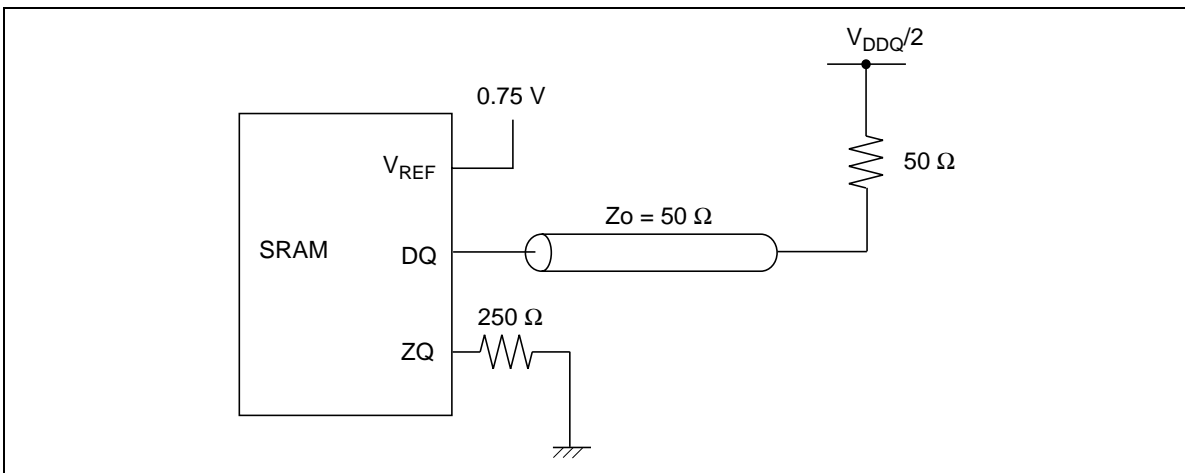

**Operating Conditions**

Parameter	Symbol	Min	Typ	Max	Unit	Notes
Input high voltage	$V_{IH(AC)}$	$V_{REF} + 0.2$	—	—	V	1, 2, 3, 4
Input low voltage	$V_{IL(AC)}$	—	—	$V_{REF} - 0.2$	V	1, 2, 3, 4

- Notes:
- All voltages referenced to  $V_{SS}$  (GND).
  - These conditions are for AC functions only, not for AC parameter test.
  - Overshoot:  $V_{IH(AC)} \leq V_{DDQ} + 0.5 \text{ V}$  for  $t \leq t_{KHKL}/2$

Undershoot:  $V_{IL(AC)} \geq -0.5 \text{ V}$  for  $t \leq t_{KHKL}/2$

Power-up:  $V_{IH} \leq V_{DDQ} + 0.3 \text{ V}$  and  $V_{DD} \leq 1.7 \text{ V}$  and  $V_{DDQ} \leq 1.4 \text{ V}$  for  $t \leq 200 \text{ ms}$

During normal operation,  $V_{DDQ}$  must not exceed  $V_{DD}$ . Control input signals may not have pulse widths less than  $t_{KHKL}$  (min) or operate at cycle rates less than  $t_{KHKL}$  (min).
  - To maintain a valid level, the transitioning edge of the input must:
    - Sustain a constant slew rate from the current AC level through the target AC level,  $V_{IL(AC)}$  or  $V_{IH(AC)}$ .
    - Reach at least the target AC level.
    - After the AC target level is reached, continue to maintain at least the target DC level,  $V_{IL(DC)}$  or  $V_{IH(DC)}$ .

**HM66AEB36102/18202/9402**

		HM66AEB36102/HM66AEB18202 HM66AEB9402											
		-30		-33		-40		-50		-60			
Parameter	Symbol	Min	Max	Min	Max	Min	Max	Min	Max	Min	Max	Unit	Notes
Average clock cycle time (K, $\bar{K}$ , C, $\bar{C}$ )	$t_{KHKL}$	3.00	3.47	3.30	4.20	4.00	5.25	5.00	6.30	6.00	7.88	ns	
Clock phase jitter (K, $\bar{K}$ , C, $\bar{C}$ )	$t_{KC}$ var	—	0.20	—	0.20	—	0.20	—	0.20	—	0.20	ns	3
Clock high time (K, $\bar{K}$ , C, $\bar{C}$ )	$t_{KHKL}$	1.20	—	1.32	—	1.60	—	2.00	—	2.40	—	ns	
Clock low time (K, $\bar{K}$ , C, $\bar{C}$ )	$t_{KLKH}$	1.20	—	1.32	—	1.60	—	2.00	—	2.40	—	ns	
Clock to clock (K to $\bar{K}$ , C to $\bar{C}$ )	$t_{KH/KH}$	1.35	—	1.49	—	1.80	—	2.20	—	2.70	—	ns	
Clock to clock ( $\bar{K}$ to K, $\bar{C}$ to C)	$t_{/KH/KH}$	1.35	—	1.49	—	1.80	—	2.20	—	2.70	—	ns	
Clock to data clock (K to C, $\bar{K}$ to $\bar{C}$ )	$t_{KHCH}$	0	1.30	0	1.45	0	1.80	0	2.30	0	2.80	ns	
DLL lock time (K, C)	$t_{KC}$ lock	1,024	—	1,024	—	1,024	—	1,024	—	1,024	—	Cycle	2
K static to DLL reset	$t_{KC}$ reset	30	—	30	—	30	—	30	—	30	—	ns	7
C, $\bar{C}$ high to output valid	$t_{CHQV}$	—	0.45	—	0.45	—	0.45	—	0.45	—	0.50	ns	
C, $\bar{C}$ high to output hold	$t_{CHQX}$	-0.45	—	-0.45	—	-0.45	—	-0.45	—	-0.50	—	ns	
C, $\bar{C}$ high to echo clock valid	$t_{CHCQV}$	—	0.45	—	0.45	—	0.45	—	0.45	—	0.50	ns	
C, $\bar{C}$ high to echo clock hold	$t_{CHCQX}$	-0.45	—	-0.45	—	-0.45	—	-0.45	—	-0.50	—	ns	
CQ, $\bar{CQ}$ high to output valid	$t_{CQHQV}$	—	0.25	—	0.27	—	0.30	—	0.35	—	0.40	ns	4, 7
CQ, $\bar{CQ}$ high to output hold	$t_{CQHQX}$	-0.25	—	-0.27	—	-0.30	—	-0.35	—	-0.40	—	ns	4, 7
C, $\bar{C}$ high to output high-Z	$t_{CHQZ}$	—	0.45	—	0.45	—	0.45	—	0.45	—	0.50	ns	5
C, $\bar{C}$ high to output low-Z	$t_{CHQX1}$	-0.45	—	-0.45	—	-0.45	—	-0.45	—	-0.50	—	ns	5



## HM66AEB36102/18202/9402

		HM66AEB36102/HM66AEB18202 HM66AEB9402											
		-30		-33		-40		-50		-60			
Parameter	Symbol	Min	Max	Min	Max	Min	Max	Min	Max	Min	Max	Unit	Notes
Address valid to K rising edge	$t_{AVKH}$	0.40	—	0.40	—	0.50	—	0.60	—	0.70	—	ns	1
Control inputs valid to K rising edge	$t_{IVKH}$	0.40	—	0.40	—	0.50	—	0.60	—	0.70	—	ns	1
Data-in valid to K, $\bar{K}$ rising edge	$t_{DVKH}$	0.28	—	0.30	—	0.35	—	0.40	—	0.50	—	ns	1
K rising edge to address hold	$t_{KHAX}$	0.40	—	0.40	—	0.50	—	0.60	—	0.70	—	ns	1
K rising edge to control inputs hold	$t_{KHIX}$	0.40	—	0.40	—	0.50	—	0.60	—	0.70	—	ns	1
K, $\bar{K}$ rising edge to data-in hold	$t_{KHDX}$	0.28	—	0.30	—	0.35	—	0.40	—	0.50	—	ns	1

- Notes:
1. This is a synchronous device. All addresses, data and control lines must meet the specified setup and hold times for all latching clock edges.
  2.  $V_{DD}$  slew rate must be less than 0.1 V DC per 50 ns for DLL lock retention. DLL lock time begins once  $V_{DD}$  and input clock are stable. It is recommended that the device is kept inactive during these cycles.
  3. Clock phase jitter is the variance from clock rising edge to the next expected clock rising edge.
  4. Echo clock is very tightly controlled to data valid / data hold. By design, there is a  $\pm 0.1$  ns variation from echo clock to data. The datasheet parameters reflect tester guardbands and test setup variations.
  5. Transitions are measured  $\pm 100$  mV from steady-state voltage.
  6. At any given voltage and temperature  $t_{CHQZ}$  is less than  $t_{CHQX1}$  and  $t_{CHQZ}$  less than  $t_{CHQV}$ .
  7. These parameters are sampled.

- Remarks:
1. Test conditions as specified with the output loading as shown in AC Test Conditions unless otherwise noted.
  2. Control input signals may not be operated with pulse widths less than  $t_{KHKL}$  (min).
  3. If C,  $\bar{C}$  are tied high, K,  $\bar{K}$  become the references for C,  $\bar{C}$  timing parameters.
  4.  $V_{DDQ}$  is +1.5 V DC.
  5. Control signals are  $\overline{LD}$ ,  $R/\overline{W}$ ,  $\overline{BW}$ ,  $\overline{BW0}$ ,  $\overline{BW1}$ ,  $\overline{BW2}$  and  $\overline{BW3}$ .

## Timing Waveforms

### Read and Write Timing

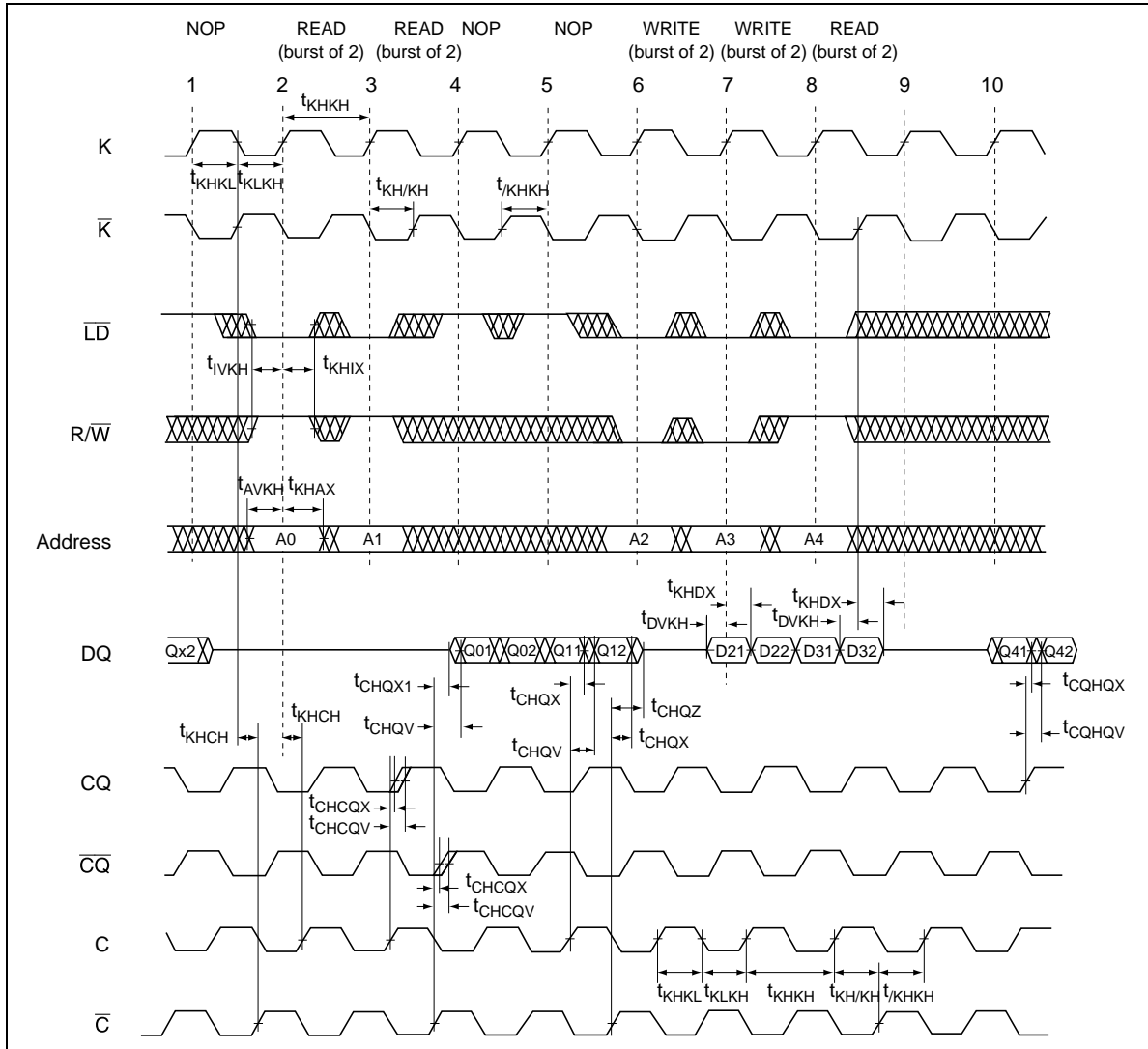

- Notes:
1. Q01 refers to output from address A0. Q02 refers to output from the next internal burst address following A0, etc.
  2. Outputs are disable (high-Z) one clock cycle after a NOP.
  3. In this example, if address A4 = A3, then data Q41 = D31, Q42 = D32. Write data is forwarded immediately as read results.
  4. To control read and write operations,  $\overline{B\overline{W}}$  signals must operate at the same timing as Data in.
  5. The second NOP cycle is not necessary for correct device operation; however, at high clock frequencies it may be required to prevent bus contention.

## JTAG Specification

These products support a limited set of JTAG functions as in IEEE standard 1149.1.

### Disabling the Test Access Port

It is possible to use this device without utilizing the TAP. To disable the TAP controller without interfering with normal operation of the device, TCK must be tied to  $V_{SS}$  to preclude mid level inputs.

TDI and TMS are designed so an undriven input will produce a response identical to the application of a logic 1, and may be left unconnected. But they may also be tied to  $V_{DD}$  through a 1k $\Omega$  resistor.

TDO should be left unconnected.

### Test Access Port (TAP) Pins

Symbol I/O	Pin assignments	Description
TCK	2R	Test clock input. All inputs are captured on the rising edge of TCK and all outputs propagate from the falling edge of TCK.
TMS	10R	Test mode select. This is the command input for the TAP controller state machine.
TDI	11R	Test data input. This is the input side of the serial registers placed between TDI and TDO. The register placed between TDI and TDO is determined by the state of the TAP controller state machine and the instruction that is currently loaded in the TAP instruction.
TDO	1R	Test data output. Output changes in response to the falling edge of TCK. This is the output side of the serial registers placed between TDI and TDO.

Note: The device does not have TRST (TAP reset). The Test-Logic Reset state is entered while TMS is held high for five rising edges of TCK. The TAP controller state is also reset on SRAM POWER-UP.

**TAP DC Operating Characteristics** ( $T_a = 0$  to  $+70^\circ\text{C}$ ,  $V_{DD} = 1.8\text{ V} \pm 0.1\text{ V}$ )

Parameter	Symbol	Min	Max	Unit	Conditions
Input high voltage	$V_{IH}$	+1.3	$V_{DD} + 0.3$	V	
Input low voltage	$V_{IL}$	-0.3	+0.5	V	
Input leakage current	$I_{LI}$	-5.0	+5.0	$\mu\text{A}$	$0\text{ V} \leq V_{IN} \leq V_{DD}$
Output leakage current	$I_{LO}$	-5.0	+5.0	$\mu\text{A}$	$0\text{ V} \leq V_{IN} \leq V_{DD}$ , output disabled
Output low voltage	$V_{OL1}$	—	0.2	V	$I_{OLC} = 100\ \mu\text{A}$
	$V_{OL2}$	—	0.4	V	$I_{OLT} = 2\ \text{mA}$
Output high voltage	$V_{OH1}$	1.6	—	V	$ I_{OHC}  = 100\ \mu\text{A}$
	$V_{OH2}$	1.4	—	V	$ I_{OHT}  = 2\ \text{mA}$

Notes: 1. All voltages referenced to  $V_{SS}$  (GND).

2. Power-up:  $V_{IH} \leq V_{DDQ} + 0.3\text{ V}$  and  $V_{DD} \leq +1.7\text{ V}$  and  $V_{DDQ} \leq +1.4\text{ V}$  for  $t \leq 200\ \text{ms}$ .

3. In "EXTTEST" mode and "SAMPLE" mode,  $V_{DDQ}$  is nominally 1.5 V.

4. ZQ:  $V_{IH} = V_{DDQ}$ .

### TAP AC Test Condition

- Temperature  $0^{\circ}\text{C} \leq T_a \leq +70^{\circ}\text{C}$
- Input timing measurement reference levels 0.9 V
- Input pulse levels 0 V to 1.8 V
- Input rise/fall time  $\leq 1.0 \text{ ns}$
- Output timing measurement reference levels 0.9 V
- Test load termination supply voltage ( $V_{TT}$ ) 0.9 V
- Output load See figures

Input waveform

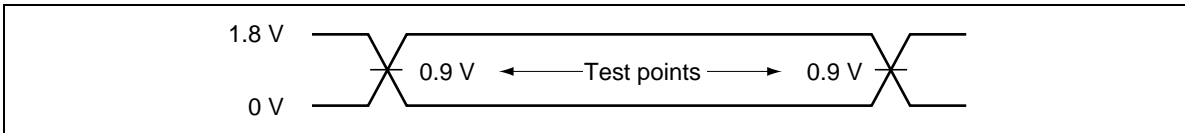

Output waveform

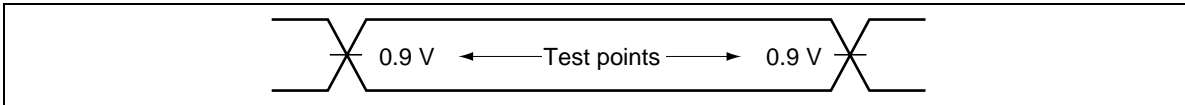

Output load

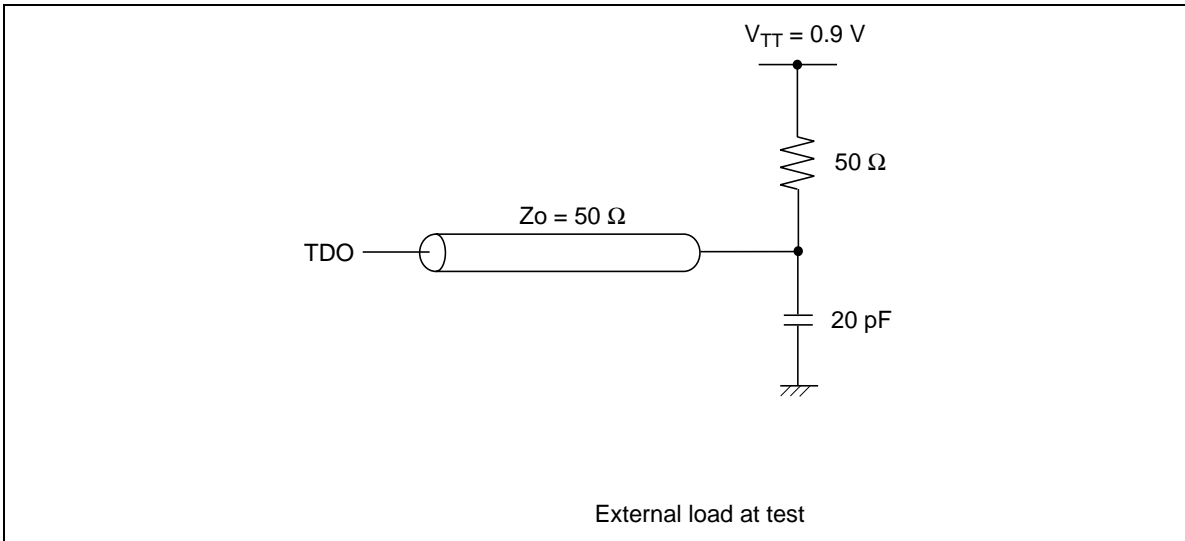

**TAP AC Operating Characteristics** ( $T_a = 0$  to  $+70^\circ\text{C}$ ,  $V_{DD} = 1.8\text{ V} \pm 0.1\text{ V}$ )

Parameter	Symbol	Min	Max	Unit	Note
Test clock cycle time	$t_{THTH}$	100	—	ns	
Test clock high pulse width	$t_{THTL}$	40	—	ns	
Test clock low pulse width	$t_{TLTH}$	40	—	ns	
Test mode select setup	$t_{MVTH}$	10	—	ns	
Test mode select hold	$t_{THMX}$	10	—	ns	
Capture setup	$t_{CS}$	10	—	ns	1
Capture hold	$t_{CH}$	10	—	ns	1
TDI valid to TCK high	$t_{DVTH}$	10	—	ns	
TCK high to TDI invalid	$t_{THDX}$	10	—	ns	
TCK low to TDO unknown	$t_{TLQX}$	0	—	ns	
TCK low to TDO valid	$t_{TLQV}$	—	20	ns	

Note: 1.  $t_{CS} + t_{CH}$  defines the minimum pause in RAM I/O pad transitions to assure pad data capture.

**TAP Controller Timing Diagram**

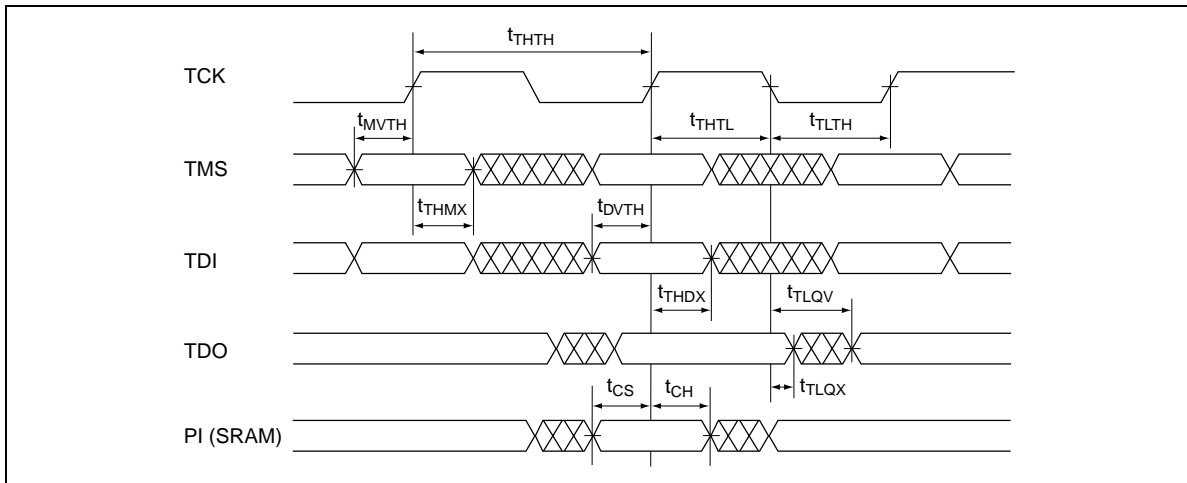

**Test Access Port Registers**

Register name	Length	Symbol
Instruction register	3 bits	IR [2:0]
Bypass register	1 bit	BP
ID register	32 bits	ID [31:0]
Boundary scan register	109 bits	BS [109:1]

## TAP Controller Instruction Set

IR2	IR1	IR0	Instruction	Description	Notes
0	0	0	EXTEST	The EXTEST instruction allows circuitry external to the component package to be tested. Boundary scan register cells at output balls are used to apply test vectors, while those at input balls capture test results. Typically, the first test vector to be applied using the EXTEST instruction will be shifted into the boundary scan register using the PRELOAD instruction. Thus, during the Update-IR state of EXTEST, the output driver is turned on and the PRELOAD data is driven onto the output balls.	1, 2, 3
0	0	1	IDCODE	The IDCODE instruction causes the ID ROM to be loaded into the ID register when the controller is in capture-DR mode and places the ID register between the TDI and TDO balls in shift-DR mode. The IDCODE instruction is the default instruction loaded in at power up and any time the controller is placed in the Test-Logic-Reset state.	
0	1	0	SAMPLE-Z	If the SAMPLE-Z instruction is loaded in the instruction register, all RAM outputs are forced to an inactive drive state (high-Z), moving the TAP controller into the capture-DR state loads the data in the RAMs input into the boundary scan register, and the boundary scan register is connected between TDI and TDO when the TAP controller is moved to the shift-DR state.	3, 4
0	1	1	RESERVED	The RESERVED instructions are not implemented but are reserved for future use. Do not use these instructions.	
1	0	0	SAMPLE (/PRELOAD)	When the SAMPLE instruction is loaded in the instruction register, moving the TAP controller into the capture-DR state loads the data in the RAMs input and I/O buffers into the boundary scan register. Because the RAM clock(s) are independent from the TAP clock (TCK) it is possible for the TAP to attempt to capture the I/O ring contents while the input buffers are in transition (i.e., in a metastable state). Although allowing the TAP to SAMPLE metastable input will not harm the device, repeatable results cannot be expected. Moving the controller to shift-DR state then places the boundary scan register between the TDI and TDO balls.	3
1	0	1	RESERVED		
1	1	0	RESERVED		
1	1	1	BYPASS	The BYPASS instruction is loaded in the instruction register when the bypass register is placed between TDI and TDO. This occurs when the TAP controller is moved to the shift-DR state. This allows the board level scan path to be shortened to facilitate testing of other devices in the scan path.	

## HM66AEB36102/18202/9402

---

- Notes:
1. Data in output register is not guaranteed if EXTEST instruction is loaded.
  2. After performing EXTEST, power-up conditions are required in order to return part to normal operation.
  3. RAM input signals must be stabilized for long enough to meet the TAPs input data capture setup plus hold time ( $t_{cs}$  plus  $t_{ch}$ ). The RAMs clock inputs need not be paused for any other TAP operation except capturing the I/O ring contents into the boundary scan register.
  4. Clock recovery initialization cycles are required to return from the SAMPLE-Z instruction.

### ID Register

Part	Revision number (31:29)	Type number (28:12)	Vendor JEDEC code (11:1)	Start bit (0)
HM66AEB36102	000	00010011010000000	01000100011	1
HM66AEB18202	000	00010010010000000	01000100011	1
HM66AEB9402	000	00010000010000000	01000100011	1



## Boundary Scan Order

Bit #	Ball ID	Signal names		
		x9	x18	x36
1	6R	$\overline{C}$	$\overline{C}$	$\overline{C}$
2	6P	C	C	C
3	6N	SA	SA	SA
4	7P	SA	SA	SA
5	7N	SA	SA	SA
6	7R	SA	SA	SA
7	8R	SA	SA	SA
8	8P	SA	SA	SA
9	9R	SA	SA	SA
10	11P	DQ0	DQ0	DQ0
11	10P	NC	NC	DQ9
12	10N	NC	NC	NC
13	9P	NC	NC	NC
14	10M	NC	DQ1	DQ11
15	11N	NC	NC	DQ10
16	9M	NC	NC	NC
17	9N	NC	NC	NC
18	11L	DQ1	DQ2	DQ2
19	11M	NC	NC	DQ1
20	9L	NC	NC	NC
21	10L	NC	NC	NC
22	11K	NC	DQ3	DQ3
23	10K	NC	NC	DQ12
24	9J	NC	NC	NC
25	9K	NC	NC	NC
26	10J	DQ2	DQ4	DQ13
27	11J	NC	NC	DQ4
28	11H	ZQ	ZQ	ZQ
29	10G	NC	NC	NC
30	9G	NC	NC	NC
31	11F	NC	DQ5	DQ5
32	11G	NC	NC	DQ14
33	9F	NC	NC	NC
34	10F	NC	NC	NC
35	11E	DQ3	DQ6	DQ6

Bit #	Ball ID	Signal names		
		x9	x18	x36
36	10E	NC	NC	DQ15
37	10D	NC	NC	NC
38	9E	NC	NC	NC
39	10C	NC	DQ7	DQ17
40	11D	NC	NC	DQ16
41	9C	NC	NC	NC
42	9D	NC	NC	NC
43	11B	DQ4	DQ8	DQ8
44	11C	NC	NC	DQ7
45	9B	NC	NC	NC
46	10B	NC	NC	NC
47	11A	CQ	CQ	CQ
48	10A	SA	SA	NC
49	9A	SA	SA	SA
50	8B	SA	SA	SA
51	7C	SA	SA	SA
52	6C	SA	SA0	SA0
53	8A	$\overline{LD}$	$\overline{LD}$	$\overline{LD}$
54	7A	NC	NC	$\overline{BW1}$
55	7B	$\overline{BW}$	$\overline{BW0}$	$\overline{BW0}$
56	6B	K	K	K
57	6A	$\overline{K}$	$\overline{K}$	$\overline{K}$
58	5B	NC	NC	$\overline{BW3}$
59	5A	NC	$\overline{BW1}$	$\overline{BW2}$
60	4A	R/ $\overline{W}$	R/ $\overline{W}$	R/ $\overline{W}$
61	5C	SA	SA	SA
62	4B	SA	SA	SA
63	3A	SA	SA	SA
64	2A	$V_{ss}$	$V_{ss}$	$V_{ss}$
65	1A	$\overline{CQ}$	$\overline{CQ}$	$\overline{CQ}$
66	2B	NC	DQ9	DQ27
67	3B	NC	NC	DQ18
68	1C	NC	NC	NC
69	1B	NC	NC	NC
70	3D	NC	DQ10	DQ19

Bit #	Ball ID	Signal names		
		x9	x18	x36
71	3C	NC	NC	DQ28
72	1D	NC	NC	NC
73	2C	NC	NC	NC
74	3E	DQ5	DQ11	DQ20
75	2D	NC	NC	DQ29
76	2E	NC	NC	NC
77	1E	NC	NC	NC
78	2F	NC	DQ12	DQ30
79	3F	NC	NC	DQ21
80	1G	NC	NC	NC
81	1F	NC	NC	NC
82	3G	DQ6	DQ13	DQ22
83	2G	NC	NC	DQ31
84	1H	$\overline{\text{DOFF}}$	$\overline{\text{DOFF}}$	$\overline{\text{DOFF}}$
85	1J	NC	NC	NC
86	2J	NC	NC	NC
87	3K	NC	DQ14	DQ23
88	3J	NC	NC	DQ32
89	2K	NC	NC	NC
90	1K	NC	NC	NC

Bit #	Ball ID	Signal names		
		x9	x18	x36
91	2L	DQ7	DQ15	DQ33
92	3L	NC	NC	DQ24
93	1M	NC	NC	NC
94	1L	NC	NC	NC
95	3N	NC	DQ16	DQ25
96	3M	NC	NC	DQ34
97	1N	NC	NC	NC
98	2M	NC	NC	NC
99	3P	DQ8	DQ17	DQ26
100	2N	NC	NC	DQ35
101	2P	NC	NC	NC
102	1P	NC	NC	NC
103	3R	SA	SA	SA
104	4R	SA	SA	SA
105	4P	SA	SA	SA
106	5P	SA	SA	SA
107	5N	SA	SA	SA
108	5R	SA	SA	SA
109	—	INTER- NAL	INTER- NAL	INTER- NAL

Note: In boundary scan mode,

1. Clock balls (K /  $\overline{K}$ , C /  $\overline{C}$ ) are referenced to each other and must be at opposite logic levels for reliable operation.
2. CQ and  $\overline{CQ}$  data are synchronized to the respective C and  $\overline{C}$  (except EXTEST, SAMPLE-Z).
3. If C and  $\overline{C}$  tied high, CQ is generated with respect to K and  $\overline{CQ}$  is generated with respect to  $\overline{K}$  (except EXTEST, SAMPLE-Z).
4. ZQ must be driven to  $V_{DDQ}$  supply to ensure consistent results.

### TAP Controller State Diagram

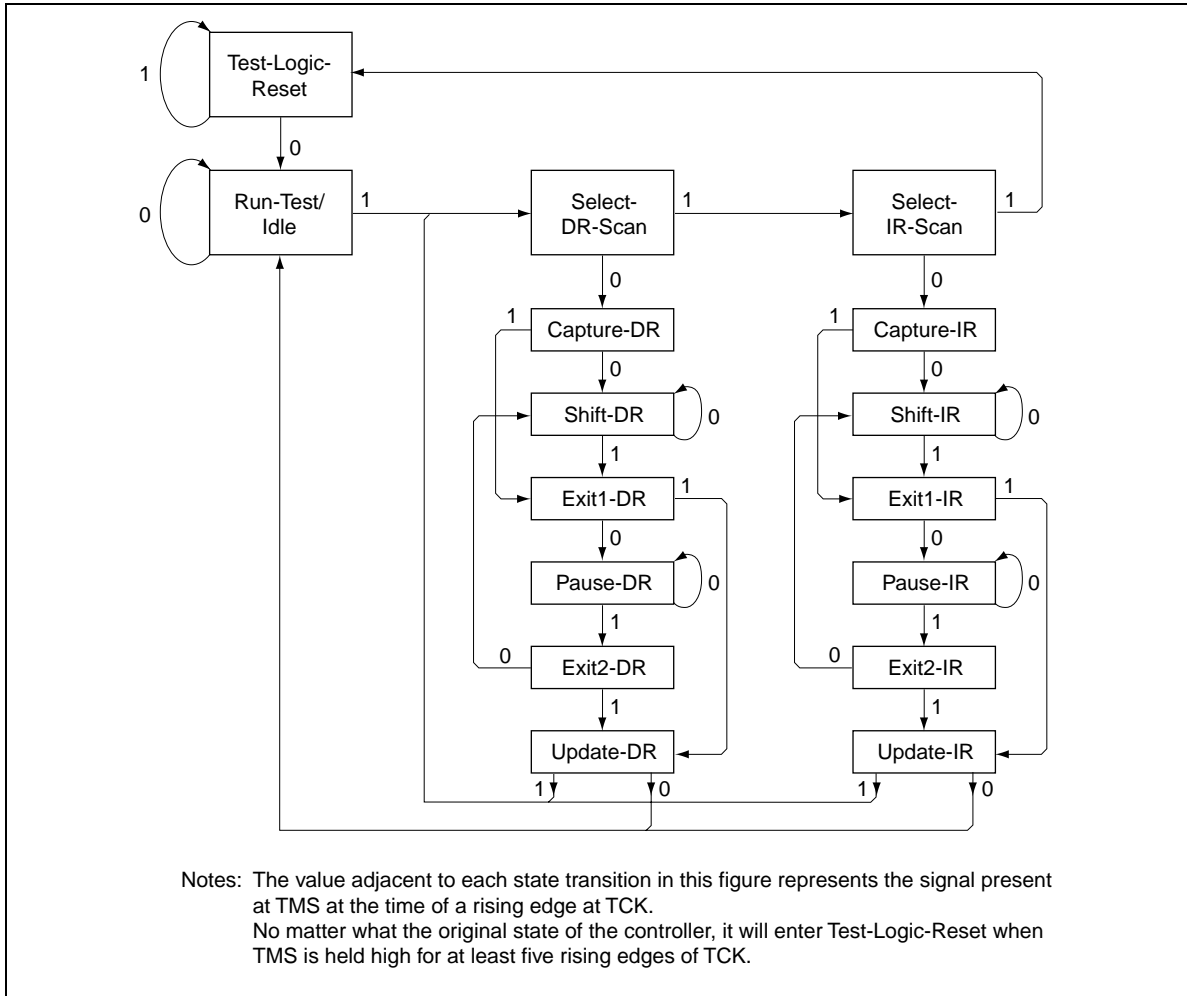

Package Dimensions

HM66AEB36102/18202/9402BP (BP-165A)

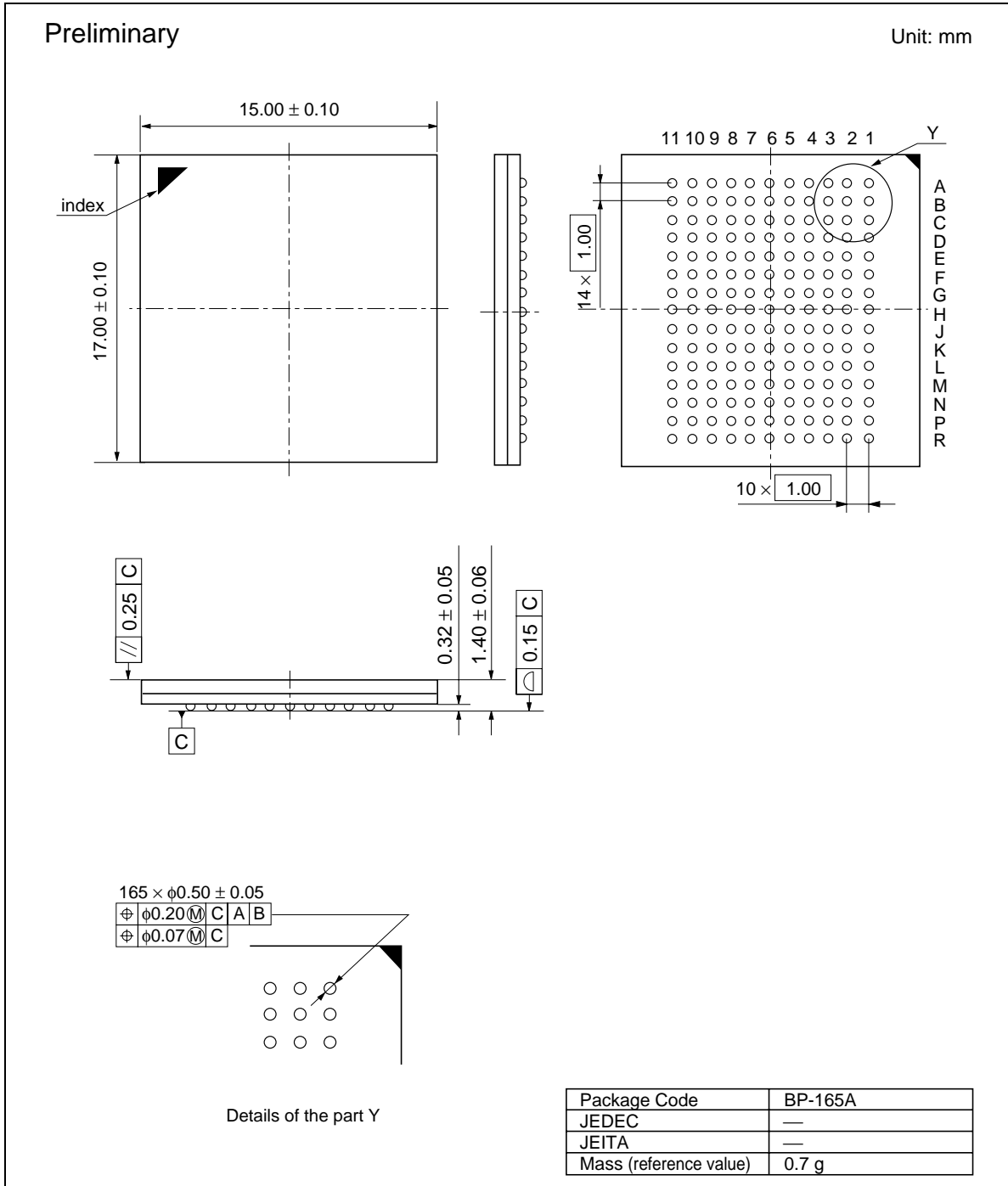

## Revision History

## HM66AEB36102/HM66AEB18202 HM66AEB9402 Data Sheet

Rev.	Date	Contents of Modification	
		Page	Description
0.0	Dec. 18, 2002	—	Initial issue
0.01	Apr.28.2004	—	Change format issued by Renesas Technology Corp.
		—	HM66AEB9402: Change of pin names
			DQ0 to DQ1
			DQ1 to DQ2
			DQ2 to DQ3
			DQ3 to DQ4
			DQ4 to DQ5
			DQ5 to DQ6
			DQ6 to DQ7
			DQ7 to DQ8
			DQ8 to DQ0
		4	Addition of Notes on Usage
		5-6	Pin Descriptions
			SA0/SAn to SA0/SA
			SA0/SA: Change of Descriptions
			K, $\bar{K}$ : Change of Descriptions
			C, $\bar{C}$ : Change of Descriptions
			ZQ: Change of Descriptions
			DQ0 to DQn: Change of Descriptions
			V <sub>REF</sub> : Change of Descriptions
			NC: Change of Descriptions
		7-8	Block Diagram
			Change of the figures
		9	Truth Table
			D <sub>A</sub> (A1) to D(A1)
			D <sub>A</sub> (A2) to D(A2)
			Q <sub>A</sub> (A1) to Q(A1)
			Q <sub>A</sub> (A2) to Q(A2)
			Change of Notes3, 6
		10-11	Byte Write Truth Table
			0 to L
			1 to H
		11	Bus Cycle State Diagram
			Change of Notes1
		12	Absolute Maximum Ratings
			V <sub>IN</sub> , V <sub>IO</sub> , V <sub>DD</sub> , V <sub>DDQ</sub> (Notes4)
			Maximum value: 2.9 V to 2.5 V
		12	Recommended DC Operating Conditions
			Deletion of Notes2
			Notes3 to Notes2
			Change of Notes2
			Addition of Notes3

Rev.	Date	Contents of Modification	
		Page	Description
0.01	Apr.28.2004	13	DC Characteristics (1st table) $I_{DD}$ (Max): ×9, ×18: 525/475/400/330/280 mA to 770/720/630/540/480 mA ×36: 710/640/545/445/380 mA to 880/800/700/600/520 mA $I_{SB1}$ (Max): ×9, ×18: 255/235/200/170/150 mA to 350/330/300/280/260 mA ×36: 265/240/210/180/160 mA to 350/330/300/280/260 mA $I_{DD}$ , $I_{SB1}$ : Addition of Notes Deletion of Notes3 Notes4 to Notes3 Addition of Notes4 Notes1-5 are moved to DC Characteristics (2nd table)
		13	DC Characteristics (2nd table) Deletion of $I_{OH}$ , $I_{OL}$ Deletion of Notes5-7, 10 Notes1-4 to Notes6-9 Notes8-9 to Notes10-11
		14	Capacitance Change of condition $C_{I/O}$ : Change of Parameter Change of Notes2
		14	AC Characteristics Output load condition: Change of the figure
		15	$V_{IH(AC)}$ , $V_{IL(AC)}$ : Addition of Notes4 Addition of Notes2 Notes2-3 to Notes3-4 Change of Notes3
		16	$t_{KC}$ reset, $t_{CQHQV}$ , $t_{CQHGX}$ : Addition of Notes7 $t_{CHQZ}$ , $t_{CHQX1}$ : Change of Parameter
		17	Remarks1 to Notes7 Change of Notes7 Remarks2-5 to Remarks1-4 Addition of Remarks5
		18	Timing Waveforms Notes4 to Notes5 Addition of Notes4
		20	TAP DC Operating Characteristics Addition of Notes4
		22	TAP Controller Timing Diagram Change of the figure

Rev.	Date	Contents of Modification	
		Page	Description
0.01	Apr.28.2004	23-24	TAP Controller Instruction Set SAMPLE(-PRELOAD) to SAMPLE(/PRELOAD) EXTEST, SAMPLE-Z, RESERVED, SAMPLE(/PRELOAD): Change of Description Addition of Notes3-4
		24	ID Register Vendor JEDEC code: 00000000111 to 01000100011
		25-26	Boundary Scan Order Change of Note
		28	Package Dimensions Change of the figure of BP-165A

**Renesas Technology Corp.** Sales Strategic Planning Div. Nippon Bldg., 2-6-2, Ohte-machi, Chiyoda-ku, Tokyo 100-0004, Japan

---

**Keep safety first in your circuit designs!**

1. Renesas Technology Corp. puts the maximum effort into making semiconductor products better and more reliable, but there is always the possibility that trouble may occur with them. Trouble with semiconductors may lead to personal injury, fire or property damage.  
Remember to give due consideration to safety when making your circuit designs, with appropriate measures such as (i) placement of substitutive, auxiliary circuits, (ii) use of nonflammable material or (iii) prevention against any malfunction or mishap.

**Notes regarding these materials**

1. These materials are intended as a reference to assist our customers in the selection of the Renesas Technology Corp. product best suited to the customer's application; they do not convey any license under any intellectual property rights, or any other rights, belonging to Renesas Technology Corp. or a third party.
  2. Renesas Technology Corp. assumes no responsibility for any damage, or infringement of any third-party's rights, originating in the use of any product data, diagrams, charts, programs, algorithms, or circuit application examples contained in these materials.
  3. All information contained in these materials, including product data, diagrams, charts, programs and algorithms represents information on products at the time of publication of these materials, and are subject to change by Renesas Technology Corp. without notice due to product improvements or other reasons. It is therefore recommended that customers contact Renesas Technology Corp. or an authorized Renesas Technology Corp. product distributor for the latest product information before purchasing a product listed herein.  
The information described here may contain technical inaccuracies or typographical errors.  
Renesas Technology Corp. assumes no responsibility for any damage, liability, or other loss rising from these inaccuracies or errors.  
Please also pay attention to information published by Renesas Technology Corp. by various means, including the Renesas Technology Corp. Semiconductor home page (<http://www.renesas.com>).
  4. When using any or all of the information contained in these materials, including product data, diagrams, charts, programs, and algorithms, please be sure to evaluate all information as a total system before making a final decision on the applicability of the information and products. Renesas Technology Corp. assumes no responsibility for any damage, liability or other loss resulting from the information contained herein.
  5. Renesas Technology Corp. semiconductors are not designed or manufactured for use in a device or system that is used under circumstances in which human life is potentially at stake. Please contact Renesas Technology Corp. or an authorized Renesas Technology Corp. product distributor when considering the use of a product contained herein for any specific purposes, such as apparatus or systems for transportation, vehicular, medical, aerospace, nuclear, or undersea repeater use.
  6. The prior written approval of Renesas Technology Corp. is necessary to reprint or reproduce in whole or in part these materials.
  7. If these products or technologies are subject to the Japanese export control restrictions, they must be exported under a license from the Japanese government and cannot be imported into a country other than the approved destination.  
Any diversion or reexport contrary to the export control laws and regulations of Japan and/or the country of destination is prohibited.
  8. Please contact Renesas Technology Corp. for further details on these materials or the products contained therein.
- 



**RENESAS SALES OFFICES**

<http://www.renesas.com>

**Renesas Technology America, Inc.**

450 Holger Way, San Jose, CA 95134-1368, U.S.A  
Tel: <1> (408) 382-7500 Fax: <1> (408) 382-7501

**Renesas Technology Europe Limited.**

Dukes Meadow, Millboard Road, Bourne End, Buckinghamshire, SL8 5FH, United Kingdom  
Tel: <44> (1628) 585 100, Fax: <44> (1628) 585 900

**Renesas Technology Europe GmbH**

Dornacher Str. 3, D-85622 Feldkirchen, Germany  
Tel: <49> (89) 380 70 0, Fax: <49> (89) 929 30 11

**Renesas Technology Hong Kong Ltd.**

7/F., North Tower, World Finance Centre, Harbour City, Canton Road, Hong Kong  
Tel: <852> 2265-6688, Fax: <852> 2375-6836

**Renesas Technology Taiwan Co., Ltd.**

FL 10, #99, Fu-Hsing N. Rd., Taipei, Taiwan  
Tel: <886> (2) 2715-2888, Fax: <886> (2) 2713-2999

**Renesas Technology (Shanghai) Co., Ltd.**

26/F., Ruijin Building, No.205 Maoming Road (S), Shanghai 200020, China  
Tel: <86> (21) 6472-1001, Fax: <86> (21) 6415-2952

**Renesas Technology Singapore Pte. Ltd.**

1, Harbour Front Avenue, #06-10, Keppel Bay Tower, Singapore 098632  
Tel: <65> 6213-0200, Fax: <65> 6278-8001