

NCP5623

Triple Output I2C Controlled RGB LED Driver

The NCP5623 mixed analog circuit is a triple output LED driver dedicated to the RGB illumination or backlight LCD display.

Features

- 2.7 to 5.5 V Input Voltage Range
- RGB Function Fully Supported
- Programmable Integrated Gradual Dimming
- 90 mA Total LED Current Capability
- Provides Three Independent LED Drives
- Support I2C Protocol
- This is a Pb-Free Device

Typical Applications

- Multicolor Illuminations
- Portable Back Light
- Digital Cellular Phone Camera Photo Flash
- LCD and Key Board Simultaneous Drive

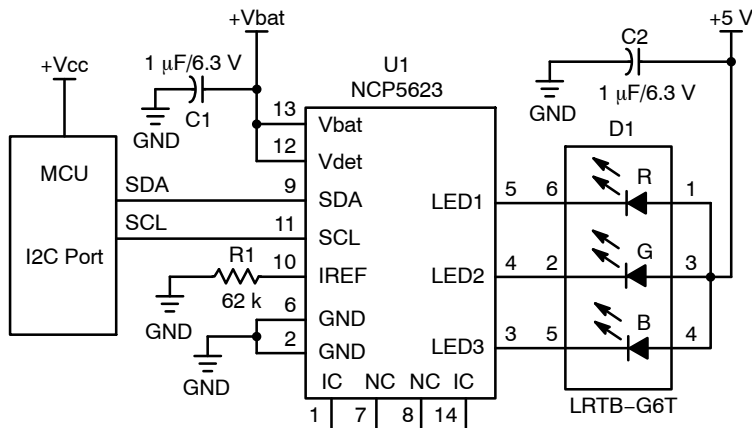

Figure 1. Typical Multiple Color LED Driver



ON Semiconductor®

<http://onsemi.com>

MARKING DIAGRAM



5623 = Specific Device Code
 A = Assembly Location
 L = Wafer Lot
 Y = Year
 W = Work Week
 ▪ = Pb-Free Package

(Note: Microdot may be in either location)

ORDERING INFORMATION

| Device | Package | Shipping† |
|---------------|--------------------|--------------------|
| NCP5623DTBR2G | TSSOP-14 (Pb-Free) | 2500 / Tape & Reel |

†For information on tape and reel specifications, including part orientation and tape sizes, please refer to our Tape and Reel Packaging Specification Brochure, BRD8011/D.

NCP5623

PIN ASSIGNMENT

| Pin | Name | Type | Description |
|------|------------------|----------------|---|
| 1 | IC | | This pin is internally connected. It must be left open. |
| 2 | GND | POWER | This pin is the GROUND signal for the analog and digital blocks and output current control. The pin must be connected to the system ground, a ground plane being strongly recommended. |
| 3 | LED3 | OUTPUT, POWER | This pin sinks to ground and monitors the current flowing into the BLUE LED, intended to be used in illumination application (Note 1). The Anode of the associated LED shall be connected to the Vbat supply. |
| 4 | LED2 | OUTPUT, POWER | This pin sinks to ground and monitors the current flowing into the GREEN LED, intended to be used in illumination application (Note 1). The Anode of the associated LED shall be connected to the Vbat supply. |
| 5 | LED1 | OUTPUT, POWER | This pin sinks to ground and monitors the current flowing into the RED LED, intended to be used in illumination application (Note 1). The anode of the associated LED shall be connected to the Vbat supply. |
| 6 | GND | ANALOG GROUND | This pin copies the Analog Ground and shall be connected to the system ground plane. |
| 7, 8 | NC | | This pin must be left floating with no connection. |
| 9 | SDA | INPUT, DIGITAL | This pin carries the data provided by the I2C protocol. The content of the SDA byte is used to program the mode of operation and to set up the output current. |
| 10 | I _{REF} | ANALOG | This pin provides the reference current, based on the internal band-gap voltage reference, to control the output current flowing in the LED. A 1% tolerance, or better, resistor shall be used to get the highest accuracy of the LED current. An external current mirror can be used to bias this pin to dynamically set up the LED maximum current. In no case shall the voltage at I _{REF} pin be forced either higher or lower than the 600 mV provided by the internal reference. |
| 11 | SCL | INPUT, DIGITAL | This pin carries the I2C clock to control the I2C communication. The SCL clock is associated with the SDA signal. |
| 12 | Vdet | INPUT | This pin provides a DC bias to the internal circuit and must be connected to the same voltage that the one applied to the Vbat pin 13. |
| 13 | Vbat | POWER | This pin is the input Battery voltage to supply the analog and digital blocks. The pin must be decoupled to ground by a 1 μ F or higher ceramic capacitor (Note 2). |
| 14 | IC | | This pin is internally connected. It must be left open. |

1. The maximum current is 37 mA for each LED
2. Using low ESR ceramic capacitor, X5R type, is recommended.

NCP5623

MAXIMUM RATINGS

| Symbol | Rating | Value | Unit |
|---|---|------------------------|---------------------------|
| V_{bat} | Power Supply (see Figure 4) | $-0.3 < V_{bat} < 7.0$ | V |
| SDA, SCL | Digital Input Voltage | $-0.3 < V < V_{bat}$ | V |
| ESD | Human Body Model: R = 1500 Ω , C = 100 pF (Note 3) | 2 | kV |
| | Machine Model | 200 | V |
| P_D $R_{\theta JC}$ $R_{\theta JA}$ | Power Dissipation @ $T_A = +85^\circ\text{C}$ (Note 4) | 235 | mW |
| | Thermal Resistance Junction to Case | 46 | $^\circ\text{C}/\text{W}$ |
| | Thermal Resistance Junction to Air | 170 | $^\circ\text{C}/\text{W}$ |
| T_A | Operating Ambient Temperature Range | -40 to +85 | $^\circ\text{C}$ |
| T_J | Operating Junction Temperature Range | -40 to +125 | $^\circ\text{C}$ |
| T_{Jmax} | Maximum Junction Temperature | +150 | $^\circ\text{C}$ |
| T_{stg} | Storage Temperature Range | -65 to +150 | $^\circ\text{C}$ |
| $I_{LATCHUP}$ | Latch-up current maximum rating per JEDEC standard: JESD78. | ± 100 | mA |

Stresses exceeding Maximum Ratings may damage the device. Maximum Ratings are stress ratings only. Functional operation above the Recommended Operating Conditions is not implied. Extended exposure to stresses above the Recommended Operating Conditions may affect device reliability.

Moisture Sensitivity Level (MSL): 1 per IPC/JEDEC standard: J-STD-020A.

3. This device series contains ESD protection and exceeds the following tests:

Human Body Model (HBM) ± 2.0 kV per JEDEC standard: JESD22-A114

Machine Model (MM) ± 200 V per JEDEC standard: JESD22-A115

4. The maximum package power dissipation limit must not be exceeded.

POWER SUPPLY SECTION:

(Typical values are referenced to $T_A = +25^\circ\text{C}$, Min & Max values are referenced -40°C to $+85^\circ\text{C}$ ambient temperature, unless otherwise noted), operating conditions $2.85 \text{ V} < V_{bat} < 5.5 \text{ V}$, unless otherwise noted.

| Pin | Symbol | Rating | Min | Typ | Max | Unit |
|-------|-------------|---|-----|-----------|-----|---------------|
| 13 | V_{bat} | Power Supply | 2.7 | | 5.5 | V |
| 13 | I_{stdb} | Stand By Current $3.0 \text{ V} \leq V_{bat} \leq 4.2 \text{ V}$, $I_{LED} = 0 \text{ mA}$ | | 0.8 | 1.0 | μA |
| 13 | I_{op} | Operating Current, @ $I_{LED} = 0 \text{ mA}$, $3.0 \text{ V} \leq V_{bat} \leq 4.2 \text{ V}$ | | 350 | | μA |
| 3,4,5 | I_{TOL} | RGB Output Current Tolerance @ $V_{bat} = 3.6 \text{ V}$, $I_{LED} = 10 \text{ mA}$ $-25^\circ\text{C} < T_A < 85^\circ\text{C}$ | | ± 3 | | % |
| 3,4,5 | I_{MATCH} | RGB Output Current LED Matching @ $V_{bat} = 3.6 \text{ V}$, $I_{LED} = 5.0 \text{ mA}$ | | ± 0.5 | | % |
| | Fpwr | Internal Clock Operating Frequency $-40^\circ\text{C} < T_A < 85^\circ\text{C}$ | 0.8 | 1 | 1.2 | MHz |

NCP5623

ANALOG SECTION:

(Typical values are referenced to $T_A = +25^\circ\text{C}$, Min & Max values are referenced -40°C to $+85^\circ\text{C}$ ambient temperature, unless otherwise noted), operating conditions $2.85\text{ V} < V_{\text{bat}} < 5.5\text{ V}$, unless otherwise noted.

| Pin | Symbol | Rating | Min | Typ | Max | Unit |
|-------|-------------------|--|-----|------|-----|------------------|
| 10 | I_{REF} | Reference current @ $V_{\text{REF}} = 600\text{ mV}$ (Note 5, Note 8) | 3 | 12.5 | 20 | μA |
| 10 | V_{REF} | Reference Voltage (Note 5) | -3% | 600 | +3% | mV |
| | I_{LEDR} | Reference Current (I_{REF}) current ratio | | 2400 | | |
| 10 | Rbias | External Reference current Bias resistor (Note 6) | 30 | 48 | 200 | $\text{k}\Omega$ |
| 3,4,5 | F_{PWM} | Internal PWM Frequency (Note 7) | | 2.1 | | kHz |

- The external circuit must not force the I_{REF} pin voltage either higher or lower than the 600 mV specified. The system is optimized with a 12.5 μA reference current.
- The overall output current tolerance depends upon the accuracy of the external resistor. Using 1% or better resistor is recommended.
- This parameter, derived from the 1 MHz clock, is guaranteed by design, not tested in production.

DIGITAL PARAMETERS SECTION:

(Typical values are referenced to $T_A = +25^\circ\text{C}$, Min & Max values are referenced -40°C to $+85^\circ\text{C}$ ambient temperature, unless otherwise noted), operating conditions $2.85\text{ V} < V_{\text{bat}} < 5.5\text{ V}$, unless otherwise noted.

| Pin | Symbol | Rating | Min | Typ | Max | Unit |
|------|------------------|---|-----|-----|------------------|------|
| 11 | F_{SCL} | Input I2C clock frequency | | | 400 | kHz |
| 9,11 | V_{IH} | Positive going Input High Voltage Threshold, SDA, SCL signals (Note 8) | 1.6 | | V_{bat} | V |
| 9,11 | V_{IL} | Negative going Input Low Voltage Threshold, SDA, SCL signals (Note 8) | 0 | | 0.4 | V |

NOTE: Digital inputs undershoot $\leq 0.30\text{ V}$ to ground, Digital inputs overshoot $< 0.30\text{ V}$ to V_{bat}

- Test guaranteed by design and fully characterized, not implemented in production.

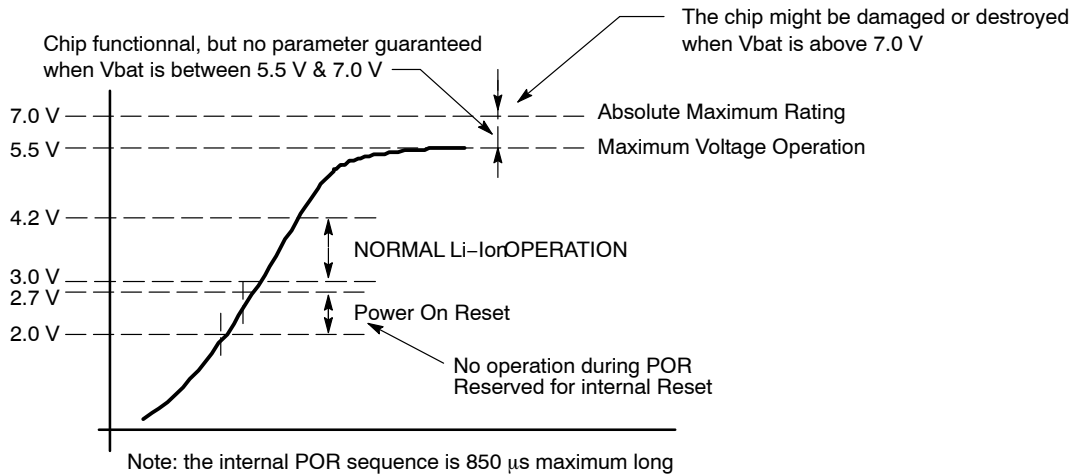

Figure 4. Understanding Integrated Circuit Voltage Limitations

NCP5623

LED MAXIMUM CURRENT CALCULATION

The load current is derived from the 600 mV reference voltage provided by the internal Band Gap associated to the external resistor connected across I_{REF} pin and Ground. Note : due to the internal structure of this pin, no voltage, either downward or upward, shall be forced at the I_{REF} pin.

The reference current is multiplied by the constant k = 2400 to yield the output load current. Since the reference voltage is based on a temperature compensated Band Gap, a tight tolerance resistor will provide a very accurate load current. The resistor is calculated from the Ohm's law ($R_{bias} = V_{REF}/I_{REF}$) and a more practical equation can be arranged to define the resistor value for a given maximum output current I_{LEDmax}:

$$R_{bias} = (V_{REF} \cdot k) / I_{LEDmax} \quad [1]$$

$$R_{bias} = (0.6 \cdot 2400) / I_{LEDmax}$$

$$R_{bias} = 1440 / I_{LEDmax} \quad [2]$$

Since the I_{REF} to I_{LEDmax} ratio is very high, it is strongly recommended to set up the reference current at 12.5 μA to optimize the tolerance of the output current. Although it is possible to use higher or lower value, as defined in the analog section, a 48 kΩ / 1% resistor will provide the best compromise, the dimming being performed by the appropriate PWM registers.

On the other hand, care must be observed to avoid leakage current flowing into either the I_{REF} pin of the bias resistor network.

Finally, for any desired I_{LED} current, the curve provided Figure 5 can be recalculated according to the equation:

$$I_{LED} = \frac{I_{REF} \cdot k}{31 - n} \quad (\text{eq. 1})$$

$$I_{LED} = \frac{V_{REF} \cdot 2400}{R_{bias} \cdot (31 - n)} \quad (\text{eq. 2})$$

with: n = step value @ 1 ≤ n ≤ 31

R_{bias} = reference resistance

k = internal multiplier constant = 2400

Note: n=0 – I_{LED} is set to zero

n = 31 – I_{LED} is set to the same current as n = 30

LOAD CONNECTION

The primary function of the NCP5623 is to control three LED arranged in the RGB color structure (reference OSRAM LATB G66x). The brightness of each LED is independently controlled by a set of dedicated PWM structure embedded into the silicon chip. The maximum current, identical for each LED, is programmable by means of the I2C data byte. With 32 steps per PWM, the chip provides 32768 colors hue in a standard display.

Moreover, a built-in gradual dimming provides a smooth brightness transition for any current level, in both Upward and Downward direction. The dimming function is controlled by the I2C interface: see Table 2.

The NCP5623 chip is capable to drive the three LED simultaneously, as depicted in Figure 1, but the load can be arranged to accommodate several LED if necessary in the application. Finally, the three current mirrors can be connected in parallel to drive a single powerful LED, thus yielding 90 mA current capability in a single LED.

I2C PROTOCOL

The NCP5623 is programmed by means of the standard I2C protocol controlled by an external MCU. The communication takes place with two serial bytes sharing the same I2C frame:

- Byte#1 → physical I2C address
- Byte#2 → Selected internal registers & function

| B7 | B6 | B5 | B4 | B3 | B2 | B1 | B0 |
|----|----|----|----|----|----|----|----|
|----|----|----|----|----|----|----|----|

Byte#1 : I2C Physical Address, based 7 bits : % 011 1000 → \$38 *

| | | | | | | | |
|---|---|---|---|---|---|---|-----|
| 0 | 1 | 1 | 1 | 0 | 0 | 0 | R/W |
|---|---|---|---|---|---|---|-----|

Byte#2 : DATA register

| | | | | | | | |
|-------|-------|-------|-------|-------|-------|-------|-------|
| RLED2 | RLED1 | RLED0 | BLED4 | BLED3 | BLED2 | BLED1 | BLED0 |
|-------|-------|-------|-------|-------|-------|-------|-------|

*Note: according to the I2C specifications, the physical address is based on 7 bits out of the SDA byte, the 8th bit representing the R/W command. Since the NCP5623 is a receiver only, the R/W command is 0 and the hexadecimal byte send by the MCU is %0111 0000 = \$70

B[7:5] : Internal Register Selection:

| B7 | B6 | B5 | Function |
|----|----|----|---|
| 0 | 0 | 0 | Chip Shut Down → all LED current = zero |
| 0 | 0 | 1 | Set up the maximum Output LED Current |
| 0 | 1 | 0 | PWM1 : Red LED control |
| 0 | 1 | 1 | PWM2 : Green LED control |
| 1 | 0 | 0 | PWM3 : Blue LED control |
| 1 | 0 | 1 | Set the Upward lend target |
| 1 | 1 | 0 | Set the Downward lend target |
| 1 | 1 | 1 | Gradual Dimming Step Time and Run |

The contain of bits B[4:0] depends upon the type of function selected by bits B[7:5] as depicted in Table 1

Table 1. Internal Register Bits Assigment

| B7 | B6 | B5 | B4 | B3 | B2 | B1 | B0 | Comments |
|----|----|----|-----------------|----------------|----------------|----------------|---------------|---|
| 0 | 0 | 0 | X | X | X | X | X | Shut down |
| 0 | 0 | 1 | 16 | 8 | 4 | 2 | 1 | LED Current Step, see Figure 5 (Note 9) |
| 0 | 1 | 0 | BPWM16 | BPWM8 | BPWM4 | BPWM2 | BPWM1 | Red PWM |
| 0 | 1 | 1 | BPWM16 | BPWM8 | BPWM4 | BPWM2 | BPWM1 | Green PWM |
| 1 | 0 | 0 | BPWM16 | BPWM8 | BPWM4 | BPWM2 | BPWM1 | Blue PWM |
| 1 | 0 | 1 | GDIM5 16 | GDIM4 8 | GDIM3 4 | GDIM2 2 | GDIM1 1 | Set Gradual Dimming Upward lend Target (Note 10) |
| 1 | 1 | 0 | GDIM5 16 | GDIM4 8 | GDIM3 4 | GDIM2 2 | GDIM1 1 | Set Gradual Dimming Downward lend Target (Note 10) |
| 1 | 1 | 1 | GDIM5 128 ms | GDIM4 64 ms | GDIM3 32 ms | GDIM2 16 ms | GDIM1 8 ms | Gradual Dimming Time & run |

9. The programmed current applies to the three LED simultaneously, the gradual dimming is not engaged

10. The bit values represent the steps count, not the ILED current: see equations 1 & 2, page 6, to derive the ILED value.

GRADUAL DIMMING

The purpose of that function is to gradually Increase or Decrease the brightness of the backlight LED upon command from the external MCU. The function is activated and controlled by means of the I2C protocol.

In order to avoid arithmetic division functions at silicon level, the period (either upward or downward) is equal to the time defined for each step, multiplied by the number of steps.

To operate such a function, the MCU will provide two information:

- 1 – The target current level (either upward or downward)
- 2 – The time per step and run

When a new gradual dimming sequence is requested, the output current increases, according to an exponential curve, from the existing start value to the end value. The end current value is defined by the contain of the Upward or Downward registers, the width of each step is defined by the Time and run register, the number of step being in the 1 to 31 range.

In the event of software error, the system checks that neither the maximum output current (30 mA), nor the zero level are forced out of their respective bounds. Similarly, software errors shall not force the NCP5623 into an uncontrolled mode of operation.

The dimming is built with 30 steps and the time delay encoded into the second byte of the I2C transaction: see Table 1.

When the gradual dimming is deactivated (B7 = B6 = 0, B5 = 1), the output current is straightforwardly set up to the level defined by the contain of the related register upon acknowledge of the output current byte.

The gradual dimming sequence must be set up before a new output current data byte is send to the NCP5623 . At this point, the brightness sequence takes place when the new data byte is acknowledged by the internal I2C decoder. Since the six registers are loaded on independent byte flow associated to the I2C address, any parameter of the NCP5623 chip can be updated ahead of the next function as depicted in Table 2.

Table 2. Basic Programming Sequences

| I2C Address | COMMAND Bits[7:0] | Operation | Note |
|-------------|------------------------|--|--|
| \$70 | 000X XXXX | System Shut Down | Bits[4:0] are irrelevant |
| \$70 | 0010 0000 0011 1111 | Set Up the ILED current | ILED register Bits[4:0] contain the ILED value as defined by the I _{REF} value |
| \$70 | 0100 0000 0101 1111 | Set Up the RED PWM | REDPWM Bits[4:0] contain the PWM value |
| \$70 | 0110 0000 0111 1111 | Set Up the GREEN PWM | GREENPWM Bits[4:0] contain the PWM value |
| \$70 | 1000 0000 1001 1111 | Set Up the BLUE PWM | BLUEPWM Bits[4:0] contain the PWM value |
| \$70 | 1010 0000 1011 1111 | Set Up the IEND Upward | UPWARD Bits[4:0] contain the IEND value |
| \$70 | 1100 0000 1101 1111 | Set Up the IEND Downward | DWNWRD Bits[4:0] contain the IEND value |
| \$70 | 1110 0001 1111 1111 | Set Up the Gradual Dimming time and run the sequence | GRAD Bits[4:0] contain the TIME value |

The number of step for a given sequence, depends upon the start and end output current range: since the ILED value is encoded in the Bits[4:0] binary scale, a maximum of 31 steps is achievable during a gradual dimming operation.

The number of steps will be automatically recalculated by the chip according to the equation:

$$Nstep = | \text{existing step position} - \text{new step position} |$$

As an example, assuming the previously programmed step was 5 and the new one is 15, then we will have 10 steps to run between the actual location to the end value. If the timing was set at 16 ms, the total gradual dimming sequence will be 160 ms.

To select the direction of the gradual dimming (either Upward or Downward), one shall send the appropriate register before to activate the sequence as depicted below:

1010 1111 → 1110 0011 → select an UPWARD sequence with 24 ms/step, the end ILED current being $(I_{REF} * 2400) / (31 - 15)$

1100 0001 → 1110 0100 → select the DOWNWARD sequence with 32 ms/step, the end ILED current being $(I_{REF} * 2400) / (31 - 1)$.

Table 3. Output Current Programmed Value (ILED = F(Step))

| Step | ILED (mA) | Step | ILED (mA) | Step | ILED (mA) | Step | ILED (mA) |
|----------|-----------|-----------|-----------|-----------|-----------|-----------|-----------|
| 0 / \$00 | 0 | 9 / \$09 | 1.25 | 18 / \$12 | 2.12 | 27 / \$1B | 6.90 |
| 1 / \$01 | 0.92 | 10 / \$0A | 1.31 | 19 / \$13 | 2.30 | 28 / \$1C | 9.20 |
| 2 / \$02 | 0.95 | 11 / \$0B | 1.38 | 20 / \$14 | 2.50 | 29 / \$1D | 13.80 |
| 3 / \$03 | 0.98 | 12 / \$0C | 1.45 | 21 / \$15 | 2.76 | 30 / \$1E | 27.60 |
| 4 / \$04 | 1.02 | 13 / \$0D | 1.53 | 22 / \$16 | 3.06 | 31 / \$1F | 27.60 |
| 5 / \$05 | 1.06 | 14 / \$0E | 1.62 | 23 / \$17 | 3.45 | | |
| 6 / \$06 | 1.10 | 15 / \$0F | 1.72 | 24 / \$18 | 3.94 | | |
| 7 / \$07 | 1.15 | 16 / \$10 | 1.84 | 25 / \$19 | 4.60 | | |
| 8 / \$08 | 1.20 | 17 / \$11 | 1.97 | 26 / \$1A | 5.52 | | |

NOTE: The table assumes I_{REF} = 11.5 μA

NCP5623

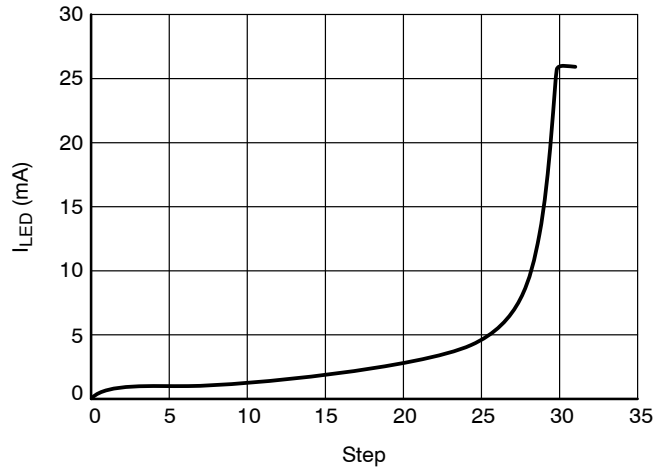

Figure 5. Output Current Programmed Value (ILED = F(Step))

PWM OPERATION

The built-in PWM are fully independent and can be programmed to any value during the normal operation of the NCP5623 chip. The PWM operate with five bits, yielding a 32 steps range to cover the full modulation (0 to 100%) of the associated LED:

- PWM = \$00 → the associated LED is fully OFF, whatever be the programmed ILED value
- PWM > \$00 but < \$1F → the brightness of the associated LED is set depending upon the PWM modulation value

- PWM = \$1F → the associated LED is fully ON, the current being the one defined by the ILED value.

Each PWM is programmable, via the I2C port as depicted, at any time under any sequence arrangement as requested by the end system's designer. The PWM does not change the ILED value, but merely modulate the ON/OFF ratio of the associated LED. Each step of the PWM represent $100/31 = 3.225\%$ of the full range, the clock being 2.1 kHz (typical).

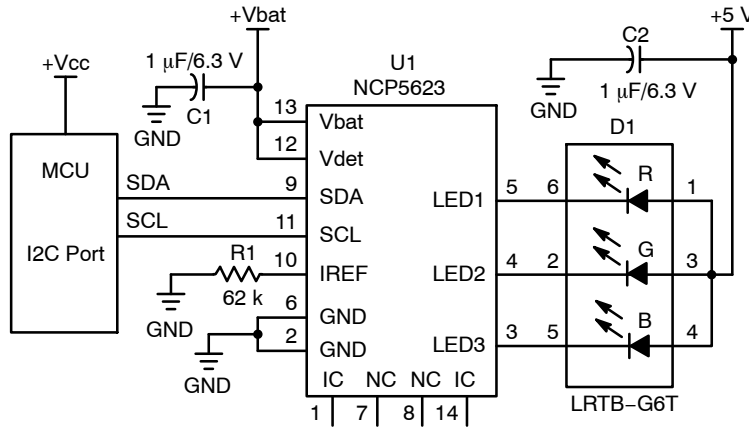

Figure 6. Basic RGB Application

onsemi, **Onsemi**, and other names, marks, and brands are registered and/or common law trademarks of Semiconductor Components Industries, LLC dba "**onsemi**" or its affiliates and/or subsidiaries in the United States and/or other countries. **onsemi** owns the rights to a number of patents, trademarks, copyrights, trade secrets, and other intellectual property. A listing of **onsemi**'s product/patent coverage may be accessed at www.onsemi.com/site/pdf/Patent-Marking.pdf. **onsemi** reserves the right to make changes at any time to any products or information herein, without notice. The information herein is provided "as-is" and **onsemi** makes no warranty, representation or guarantee regarding the accuracy of the information, product features, availability, functionality, or suitability of its products for any particular purpose, nor does **onsemi** assume any liability arising out of the application or use of any product or circuit, and specifically disclaims any and all liability, including without limitation special, consequential or incidental damages. Buyer is responsible for its products and applications using **onsemi** products, including compliance with all laws, regulations and safety requirements or standards, regardless of any support or applications information provided by **onsemi**. "Typical" parameters which may be provided in **onsemi** data sheets and/or specifications can and do vary in different applications and actual performance may vary over time. All operating parameters, including "Typicals" must be validated for each customer application by customer's technical experts. **onsemi** does not convey any license under any of its intellectual property rights nor the rights of others. **onsemi** products are not designed, intended, or authorized for use as a critical component in life support systems or any FDA Class 3 medical devices or medical devices with a same or similar classification in a foreign jurisdiction or any devices intended for implantation in the human body. Should Buyer purchase or use **onsemi** products for any such unintended or unauthorized application, Buyer shall indemnify and hold **onsemi** and its officers, employees, subsidiaries, affiliates, and distributors harmless against all claims, costs, damages, and expenses, and reasonable attorney fees arising out of, directly or indirectly, any claim of personal injury or death associated with such unintended or unauthorized use, even if such claim alleges that **onsemi** was negligent regarding the design or manufacture of the part. **onsemi** is an Equal Opportunity/Affirmative Action Employer. This literature is subject to all applicable copyright laws and is not for resale in any manner.

ADDITIONAL INFORMATION

TECHNICAL PUBLICATIONS:

Technical Library: www.onsemi.com/design/resources/technical-documentation
onsemi Website: www.onsemi.com

ONLINE SUPPORT: www.onsemi.com/support

For additional information, please contact your local Sales Representative at www.onsemi.com/support/sales