

DO NOT SCALE FROM THIS PRINT

ZF5-XX-XX-XX-WT-XX

No OF POSITIONS
-04 THRU -50

LEAD STYLE
-01: CONTACT BOTTOM
-02: CONTACT TOP
-03: VERTICAL

OPTIONS
-TR: TAPE AND REEL (SEE SHEET 3, FIG. 3)
WELD TAB

PLATING SPECIFICATION
-T: PURE TIN, MATTE FINISH
-TM: PURE TIN, MATTE FINISH (SEE NOTE 7)

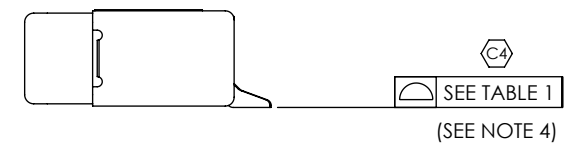
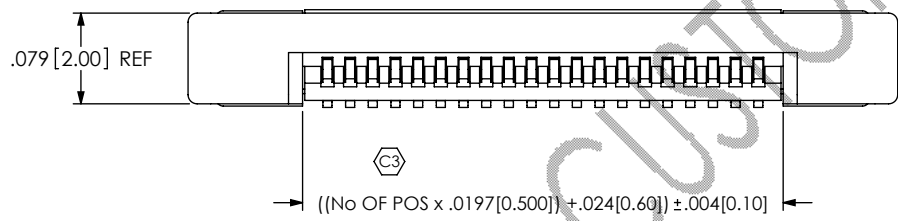
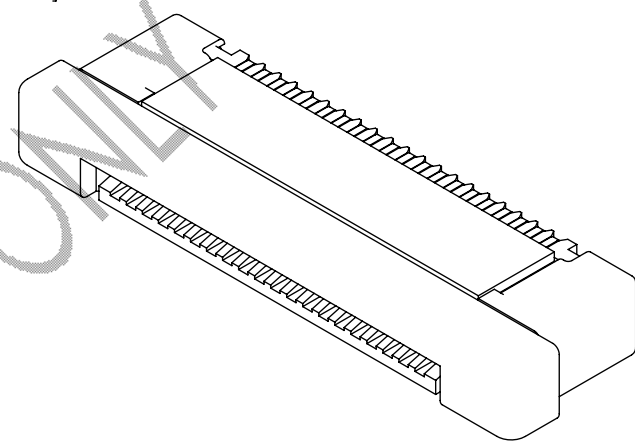
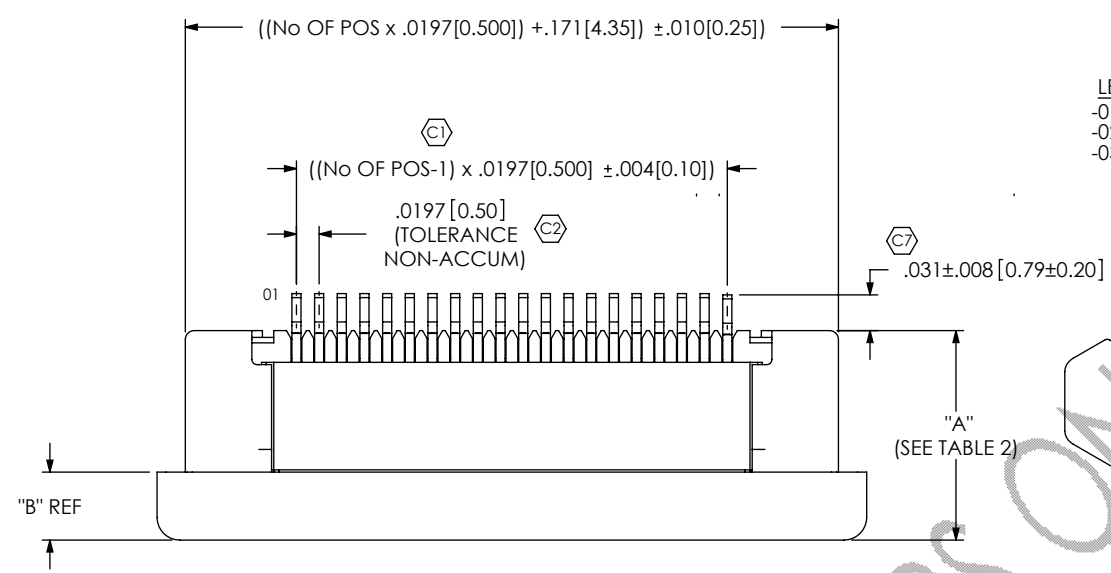

FIG 1
ZF5-20-01-X-WT SHOWN
(WITH CAM CLOSED)

No OF POS.	"A"	"B"	"C"	"D"
-04 THRU -29	.182 [4.62]	0.059 [1.50]	0.082 [2.08]	0.185 [4.70]
-30 THRU -39	.186 [4.72]	0.063 [1.60]	0.086 [2.18]	0.189 [4.80]
-40 THRU -50	.190 [4.82]	0.067 [1.70]	0.090 [2.29]	0.193 [4.90]

- NOTES:
- Ⓢ REPRESENTS A CRITICAL DIMENSION.
 - MAX BURR ALLOWANCE: .0010[.025].
 - MIN CONTACT PUSHOUT FORCE: 6 OZ.
 - CO-PLANARITY INCLUDES TAILS AND WELD TABS.
 - WELD TAB RETENTION: 6 OZ.
 - BREAKOFF BURR NOT TO EXCEED .007[0.18] AND MUST REMAIN ATTACHED.
 - .000040 MIN NICKEL AND .000100 - .000200 MIN TIN
 - PIN 1 TO HAVE ORIENTATION AS SHOWN.
 - NOTE DELETED.

No OF POS.	COPLANARITY
-04 THRU -30	.0040[0.101]
-31 THRU -50	.0060[0.152]

UNLESS OTHERWISE SPECIFIED, DIMENSIONS ARE IN INCHES. TOLERANCES ARE:

DECIMALS ANGLES
.XX: ±.01[0.3] 2°
.XXX: ±.005[0.13]
.XXXX: ±.0020[0.051]

MATERIAL: DO NOT SCALE DRAWING SHEET SCALE: 6:1
HOUSING: LCP, COLOR: NATURAL
CAM SLIDER: LCP, COLOR: BLACK
CONTACT & WELD TAB: PHOS BRONZE
MAX FLASH ALLOWED: .002
MAX GATE VESTIGE: .002
F:\DWG\MISC\Mktg\ZF5-XX-XX-XX-WT-XX-MKT.SLDDRW

PROPRIETARY NOTE
THIS DOCUMENT CONTAINS INFORMATION CONFIDENTIAL AND PROPRIETARY TO SAMTEC, INC. AND SHALL NOT BE REPRODUCED OR TRANSFERRED TO OTHER DOCUMENTS OR DISCLOSED TO OTHERS OR USED FOR ANY PURPOSE OTHER THAN THAT WHICH IT WAS OBTAINED WITHOUT THE EXPRESSED WRITTEN CONSENT OF SAMTEC, INC.

520 PARK EAST BLVD, NEW ALBANY, IN 47150
PHONE: 812-944-6733 FAX: 812-948-5047
e-Mail: info@SAMTEC.com code 55322

DESCRIPTION:
ZERO INSERTION FORCE .5mm ASSEMBLY

DWG. NO.
ZF5-XX-XX-XX-WT-XX

BY: DEAN P 12/12/2000 SHEET 1 OF 3

REVISION Y

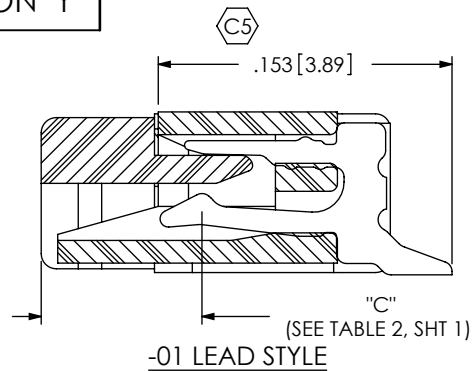

APPLICATION VIEWS

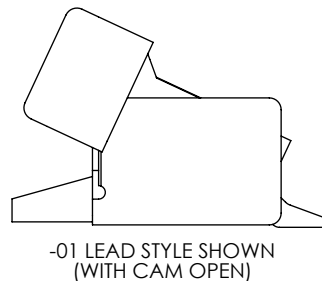

-01 LEAD STYLE SHOWN
(WITH CAM OPEN)

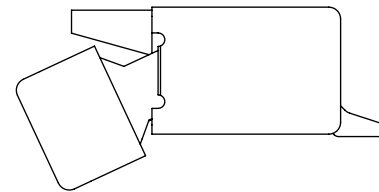

-02 LEAD STYLE SHOWN
(WITH CAM OPEN)

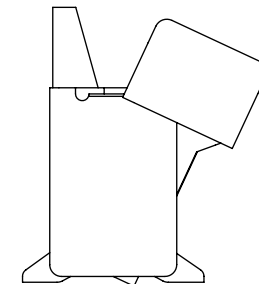

-03 LEAD STYLE SHOWN
(WITH CAM OPEN)

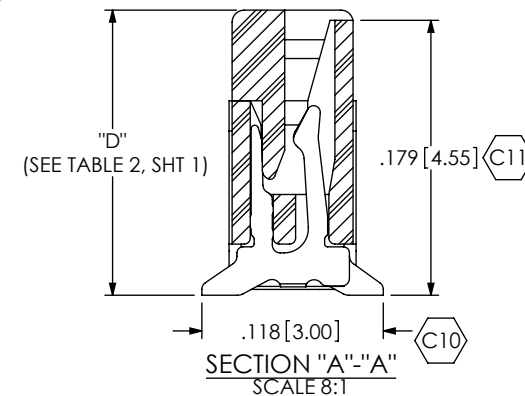
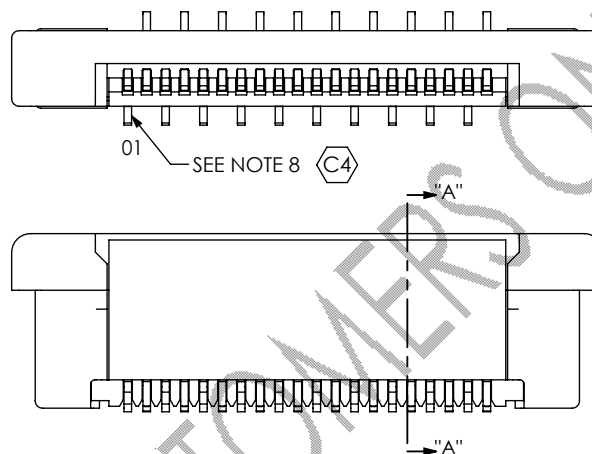
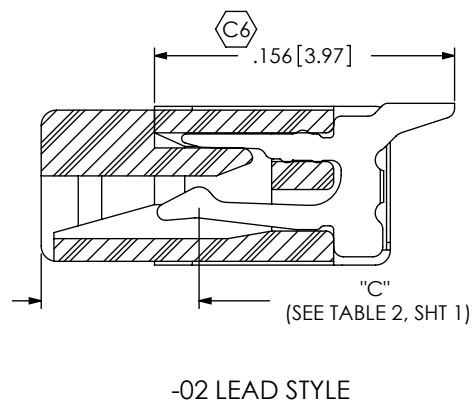

PACKAGING VIEWS
(-TR OPTION SHOWN ON SHEET 3)
[PARTS TO HAVE POSITION #1 LOADED IN
SAME DIRECTION AS ARROW ON TUBE]

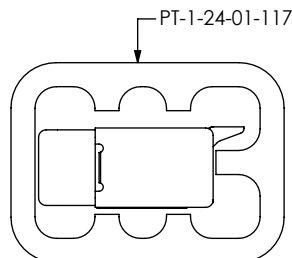

-01 & -02 LEAD STYLES
-04 THRU -39 POSITIONS

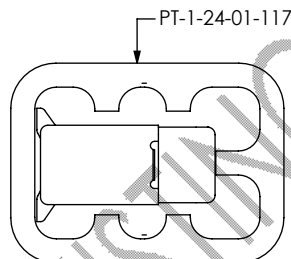

-03 LEAD STYLES
-04 THRU -39 POSITIONS

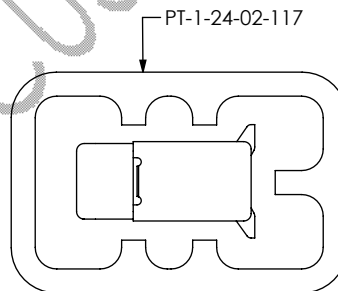

-01, -02, & -03 LEAD STYLE
-40 THRU -50 POSITIONS

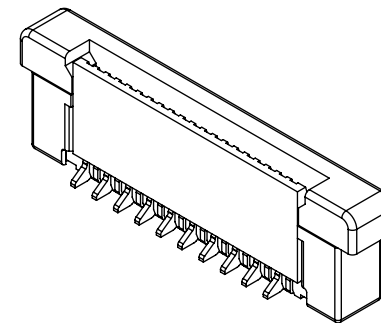

FIG 2
-03 LEAD STYLE
(SAME AS FIG 1, EXCEPT AS SHOWN)
(ZF5-20-03-T-WT-SHOWN)

PROPRIETARY NOTE
THIS DOCUMENT CONTAINS INFORMATION
CONFIDENTIAL AND PROPRIETARY TO
SAMTEC, INC. AND SHALL NOT BE REPRODUCED
OR TRANSFERRED TO OTHER DOCUMENTS OR
DISCLOSED TO OTHERS OR USED FOR ANY
PURPOSE OTHER THAN THAT WHICH IT WAS
OBTAINED WITHOUT THE EXPRESSED WRITTEN
CONSENT OF SAMTEC, INC.

DO NOT SCALE DRAWING

SHEET SCALE: 10:1



520 PARK EAST BLVD, NEW ALBANY, IN 47150
PHONE: 812-944-6733 FAX: 812-948-5047
e-Mail: info@SAMTEC.com code 55322

DESCRIPTION:
ZERO INSERTION FORCE .5mm ASSEMBLY

DWG. NO.
ZF5-XX-XX-XX-WT-XX

PACKAGING TABLE

LEAD STYLE	No OF POS.	PACKAGING TUBE	TUBE PLUG
-01, -02 & -03	-04 THRU -39	PT-1-24-01-117	TP-24
	-40 THRU -50	PT-1-24-02-117	TP-24

-01 LEAD STYLE

NOTE: PIN 1 CLOSEST TO ROUND HOLES

ROUND HOLES

POS 1

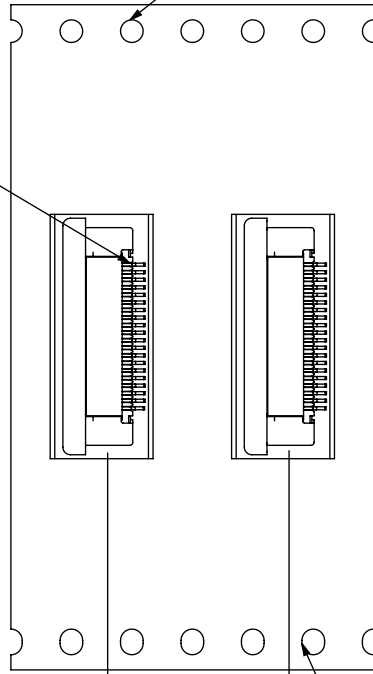

.472 [12.00]
REF

OBLONG HOLES

USER DIRECTION OF UN-REELING
POCKET NOT DETAILED

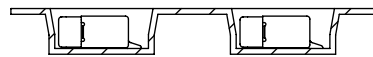

-02 LEAD STYLE

NOTE: PIN 1 CLOSEST TO OBLONG HOLES

ROUND HOLES

POS 1

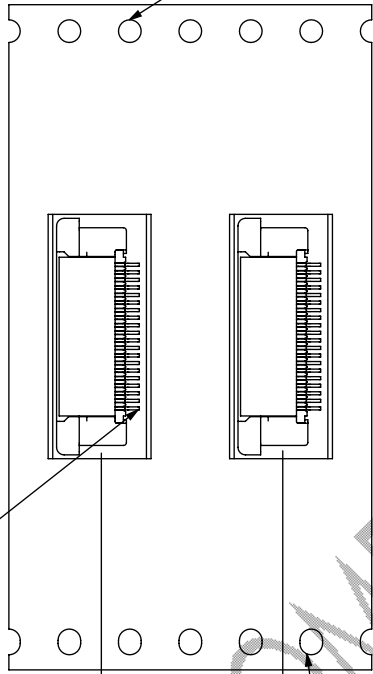

.472 [12.00]
REF

OBLONG HOLES

USER DIRECTION OF UN-REELING
POCKET NOT DETAILED

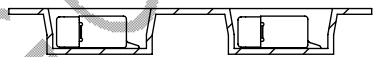

-03 LEAD STYLE

NOTE: PIN 1 CLOSEST TO ROUND HOLES

ROUND HOLES

POS 01

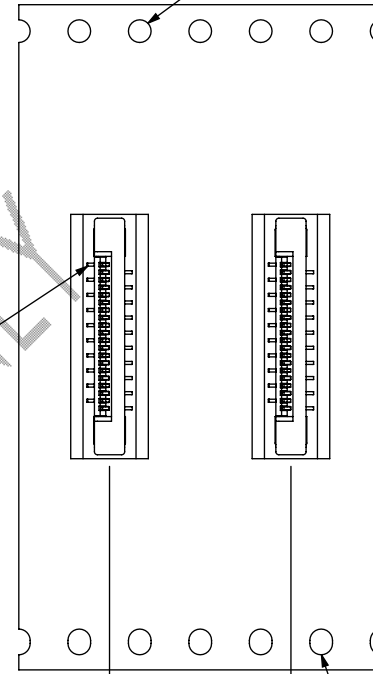

.472 [12.00]
REF

OBLONG HOLES

USER DIRECTION OF UN-REELING
POCKET NOT DETAILED

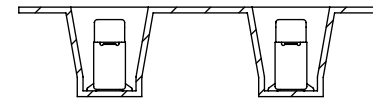

EXISTING CUSTOMERS ONLY

PROPRIETARY NOTE

THIS DOCUMENT CONTAINS INFORMATION CONFIDENTIAL AND PROPRIETARY TO SAMTEC, INC. AND SHALL NOT BE REPRODUCED OR TRANSFERRED TO OTHER DOCUMENTS OR DISCLOSED TO OTHERS OR USED FOR ANY PURPOSE OTHER THAN THAT WHICH IT WAS OBTAINED WITHOUT THE EXPRESSED WRITTEN CONSENT OF SAMTEC, INC.

SHEET SCALE: 2:1



520 PARK EAST BLVD, NEW ALBANY, IN 47150
PHONE: 812-944-6733 FAX: 812-948-5047
e-Mail: info@SAMTEC.com code 55322

DESCRIPTION:
ZERO INSERTION FORCE .5mm ASSEMBLY

DWG. NO. ZF5-XX-XX-XX-WT-XX

BY: DEAN P 12/12/2000 SHEET 3 OF 3