

DESCRIPTION

2SC2798 is a silicon NPN epitaxial planar type transistor designed for RF broad-band power amplifiers in UHF band.

FEATURES

- High power gain: $G_{pe} \geq 6\text{dB}$ (Class AB)
@ $V_{CC} = 24\text{V}$, $P_O = 12\text{W}$, $f = 770\text{MHz}$, $I_D = 50\text{mA}$
- Emitter ballasted construction and gold metallization for high reliability and good performances.
- Low thermal resistance ceramic package with stud.
- Ability of withstanding load VSWR 8.8:1 when operated at $V_{CC} = 24\text{V}$, $P_O = 12\text{W}$, $f = 175\text{MHz}$, $I_D = 50\text{mA}$, $T_C = 25^\circ\text{C}$, class AB condition.

APPLICATION

UHF high voltage (24V) broad-band amplifiers

OUTLINE DRAWING

Dimensions in mm

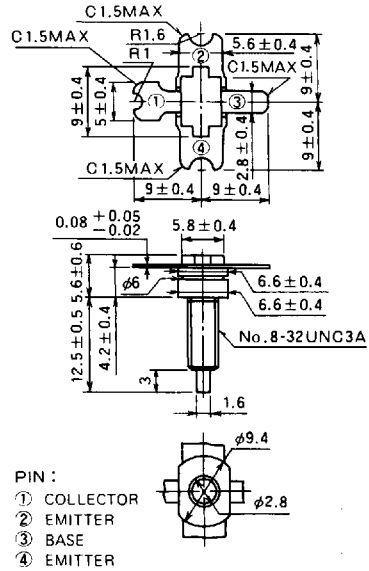

T-41 NOTE: ALL ELECTRODES ARE ISOLATED FROM FLANGE.

ABSOLUTE MAXIMUM RATINGS ($T_C = 25^\circ\text{C}$ unless otherwise specified)

Symbol	Parameter	Conditions	Ratings	Unit
V_{CBO}	Collector to base voltage		45	V
V_{EBO}	Emitter to base voltage		4	V
V_{CEO}	Collector to emitter voltage	$R_{BE} = \infty$	35	V
I_C	Collector current		2	A
P_C	Collector dissipation	$T_C = 25^\circ\text{C}$	30	W
T_j	Junction temperature		175	$^\circ\text{C}$
T_{stg}	Storage temperature		-55 to 175	$^\circ\text{C}$
R_{th-c}	Thermal resistance	Junction to case	5	$^\circ\text{C}/\text{W}$

Note. Above parameters are guaranteed independently.

ELECTRICAL CHARACTERISTICS ($T_C = 25^\circ\text{C}$ unless otherwise specified)

Symbol	Parameter	Test conditions	Limits			Unit
			Min	Typ	Max	
$V_{(BR)EBO}$	Emitter to base breakdown voltage	$I_E = 10\text{mA}$, $I_C = 0$	4			V
$V_{(BR)CBO}$	Collector to base breakdown voltage	$I_C = 10\text{mA}$, $I_E = 0$	45			V
$V_{(BR)CEO}$	Collector to emitter breakdown voltage	$I_C = 50\text{mA}$, $R_{BE} = \infty$	35			V
I_{CBO}	Collector cutoff current	$V_{CB} = 25\text{V}$, $I_E = 0$			1000	μA
I_{EBO}	Emitter cutoff current	$V_{EB} = 3\text{V}$, $I_C = 0$			400	μA
h_{FE}	DC forward current gain*	$V_{CE} = 25\text{V}$, $I_C = 0.1\text{A}$	10	40	180	—
P_O	Output power	$V_{CC} = 24\text{V}$, $P_{in} = 3\text{W}$, $f = 770\text{MHz}$, $I_D = 50\text{mA}^{**}$	12	14		W
η_C	Collector efficiency		55	60		%

Note. * Pulse test, $P_W = 150\mu\text{s}$, duty = 5%. ** Class AB operation.
Above parameters, ratings, limits: and conditions are subject to change.

TEST CIRCUIT

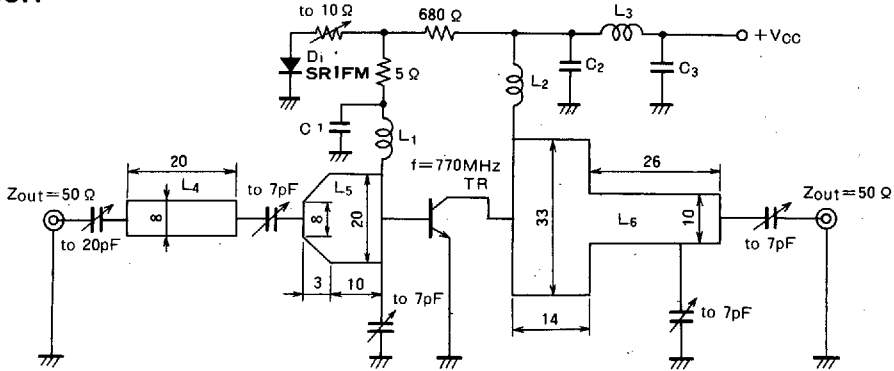

- L1: 4D, 6T, 3P, 0.4mmφ enameled wire
- L2: Width = 3mm, thickness = 0.15mm, length = 23mm copper plate
- L3: 4D, 20T, 1P, 0.4mmφ enameled wire
- L4~L6: Microstrip line (t = 1.6mm, ε_s = 2.7 Teflon)

- C1: 1000pF, 0.01μF in parallel
- C2: 100pF, 1000pF, 0.01μF, 1μF in parallel
- C3: 100pF, 1000pF, 0.1μF, 10μF in parallel

NOTES: Coil dimensions in milli-meter
 D: Inner diameter of coil
 T: Turn number of coil
 P: Pitch of coil

TYPICAL PERFORMANCE DATA

COLLECTOR DISSIPATION VS. AMBIENT TEMPERATURE

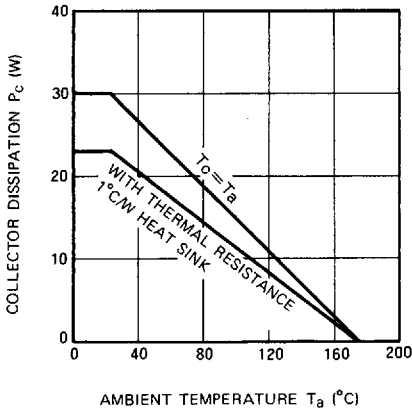

OUTPUT POWER, COLLECTOR EFFICIENCY VS. INPUT POWER

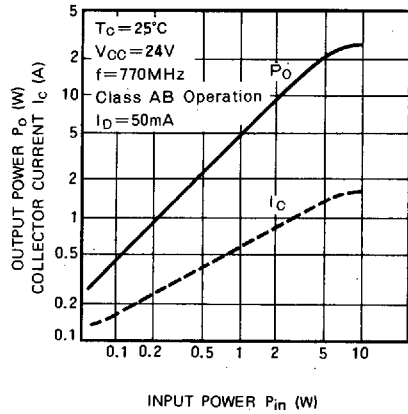

COLLECTOR OUTPUT CAPACITANCE VS. COLLECTOR TO BASE VOLTAGE

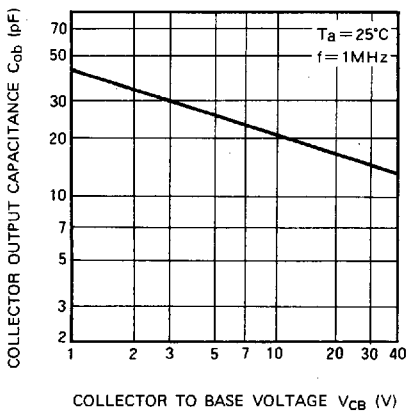

DC CURRENT GAIN VS. COLLECTOR CURRENT

