

# SN54ALS646, SN54ALS648, SN54AS646 SN74ALS646A, SN74ALS648A, SN74AS646, SN74AS648 OCTAL BUS TRANSCEIVERS AND REGISTERS WITH 3-STATE OUTPUTS

SDAS039F - DECEMBER 1983 - REVISED JANUARY 1995

- Independent Registers for A and B Buses
- Multiplexed Real-Time and Stored Data
- Choice of True or Inverting Data Paths
- Choice of 3-State or Open-Collector Outputs
- Package Options Include Plastic Small-Outline (DW) Packages, Ceramic Chip Carriers (FK), and Standard Plastic (NT) and Ceramic (JT) 300-mil DIPs

SN54ALS646, SN54ALS648, SN54AS646 ... JT PACKAGE  
SN74ALS646A, SN74ALS648A, SN74AS646, SN74AS648 ... DW OR NT PACKAGE  
(TOP VIEW)

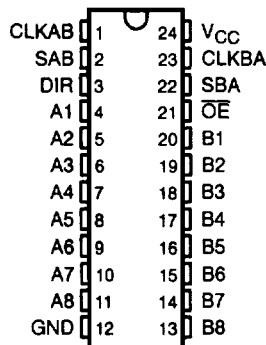

DEVICE	OUTPUT	LOGIC
SN54ALS646, SN74ALS646A, AS646	3 state	True
SN54ALS648, SN74ALS648A, SN74AS648	3 state	Inverting

## description

These devices consist of bus-transceiver circuits with 3-state or open-collector outputs, D-type flip-flops, and control circuitry arranged for multiplexed transmission of data directly from the data bus or from the internal storage registers. Data on the A or B bus is clocked into the registers on the low-to-high transition of the appropriate clock (CLKAB or CLKBA) input. Figure 1 illustrates the four fundamental bus-management functions that can be performed with the octal bus transceivers and registers.

Output-enable ( $\overline{OE}$ ) and direction-control (DIR) inputs control the transceiver functions. In the transceiver mode, data present at the high-impedance port may be stored in either or both registers.

The select-control (SAB and SBA) inputs can multiplex stored and real-time (transparent mode) data. The circuitry used for select control eliminates the typical decoding glitch that occurs in a multiplexer during the transition between stored and real-time data. DIR determines which bus receives data when  $\overline{OE}$  is low. In the isolation mode ( $\overline{OE}$  high), A data may be stored in one register and/or B data may be stored in the other register.

When an output function is disabled, the input function is still enabled and can be used to store and transmit data. Only one of the two buses, A or B, may be driven at a time.

The -1 version of the SN74ALS646A is identical to the standard version, except that the recommended maximum  $I_{OL}$  in the -1 version is increased to 48 mA. There are no -1 versions of the SN54ALS646, SN54ALS648, or SN74ALS648A.

The SN54ALS646, SN54ALS648, and SN54AS646 are characterized for operation over the full military temperature range of  $-55^{\circ}\text{C}$  to  $125^{\circ}\text{C}$ . The SN74ALS646A, SN74ALS648A, SN74AS646, and SN74AS648 are characterized for operation from  $0^{\circ}\text{C}$  to  $70^{\circ}\text{C}$ .

SN54ALS646, SN54ALS648, SN54AS646 ... FK PACKAGE  
(TOP VIEW)

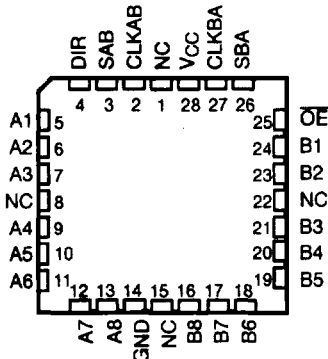

NC - No internal connection

PRODUCTION DATA Information is current as of publication date. Products conform to specifications per the terms of Texas Instruments standard warranty. Production processing does not necessarily include testing of all parameters.



POST OFFICE BOX 655303 • DALLAS, TEXAS 75285

Copyright © 1995, Texas Instruments Incorporated

**SN54ALS646, SN54ALS648, SN54AS646**  
**SN74ALS646A, SN74ALS648A, SN74AS646, SN74AS648**  
**OCTAL BUS TRANSCEIVERS AND REGISTERS WITH 3-STATE OUTPUTS**  
SDAS039F - DECEMBER 1983 - REVISED JANUARY 1985

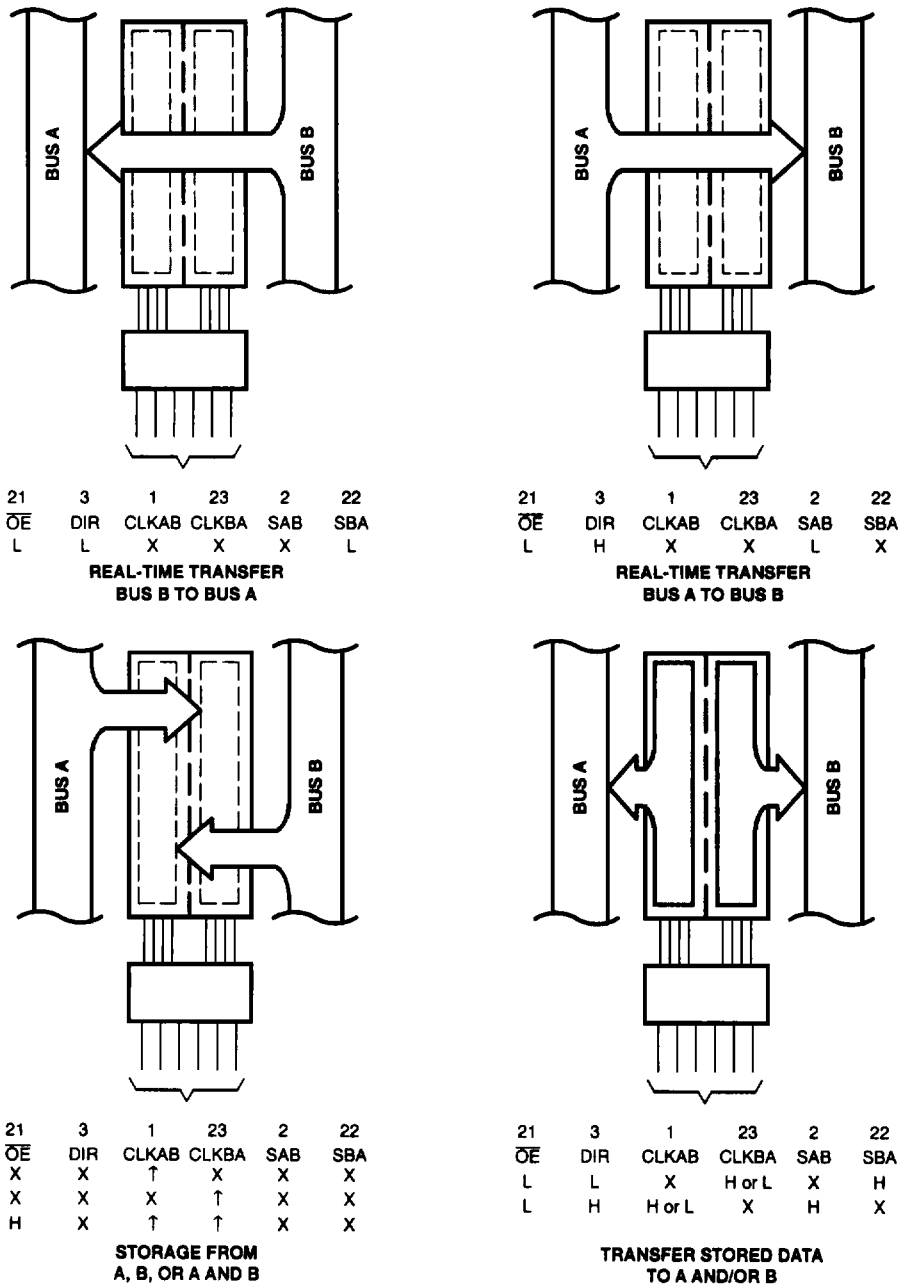

**Figure 1. Bus-Management Functions**

Pin numbers shown are for the DW, JT, and NT packages.



POST OFFICE BOX 655303 • DALLAS, TEXAS 75265

**SN54ALS646, SN54ALS648, SN54AS646**  
**SN74ALS646A, SN74ALS648A, SN74AS646, SN74AS648**  
**OCTAL BUS TRANSCEIVERS AND REGISTERS WITH 3-STATE OUTPUTS**

SDAS039F - DECEMBER 1983 - REVISED JANUARY 1995

**Function Tables**

**SN54ALS646, SN54AS646, SN74ALS646A, SN74AS646**

INPUTS						DATA I/O		OPERATION OR FUNCTION
$\overline{OE}$	DIR	CLKAB	CLKBA	SAB	SBA	A1-A8	B1-B8	
X	X	↑	X	X	X	Input	Unspecified†	Store A, B unspecified†
X	X	X	↑	X	X	Unspecified†	Input	Store B, A unspecified†
H	X	↑	↑	X	X	Input	Input	Store A and B data
H	X	H or L	H or L	X	X	Input disabled	Input disabled	Isolation, hold storage
L	L	X	X	X	L	Output	Input	Real-time B data to A bus
L	L	X	H or L	X	H	Output	Input	Stored B data to A bus
L	H	X	X	L	X	Input	Output	Real-time A data to B bus
L	H	H or L	X	H	X	Input	Output	Stored A data to B bus

† The data output functions can be enabled or disabled by various signals at  $\overline{OE}$  and DIR. Data input functions are always enabled; i.e., data at the bus terminals is stored on every low-to-high transition of the clock inputs.

**SN54ALS648, SN74ALS648A, SN74AS648**

INPUTS						DATA I/O		OPERATION OR FUNCTION
$\overline{OE}$	DIR	CLKAB	CLKBA	SAB	SBA	A1-A8	B1-B8	
X	X	↑	X	X	X	Input	Unspecified†	Store A, B unspecified†
X	X	X	↑	X	X	Unspecified†	Input	Store B, A unspecified†
H	X	↑	↑	X	X	Input	Input	Store A and B data
H	X	H or L	H or L	X	X	Input disabled	Input disabled	Isolation, hold storage
L	L	X	X	X	L	Output	Input	Real-time $\overline{B}$ data to A bus
L	L	X	H or L	X	H	Output	Input	Stored $\overline{B}$ data to A bus
L	H	X	X	L	X	Input	Output	Real-time $\overline{A}$ data to B bus
L	H	H or L	X	H	X	Input	Output	Stored $\overline{A}$ data to B bus

† The data output functions can be enabled or disabled by various signals at  $\overline{OE}$  and DIR. Data input functions are always enabled; i.e., data at the bus terminals is stored on every low-to-high transition of the clock inputs.



**SN54ALS646, SN54ALS648, SN54AS646**  
**SN74ALS646A, SN74ALS648A, SN74AS646, SN74AS648**  
**OCTAL BUS TRANSCEIVERS AND REGISTERS WITH 3-STATE OUTPUTS**  
 SDAS039F - DECEMBER 1983 - REVISED JANUARY 1985

logic symbol†

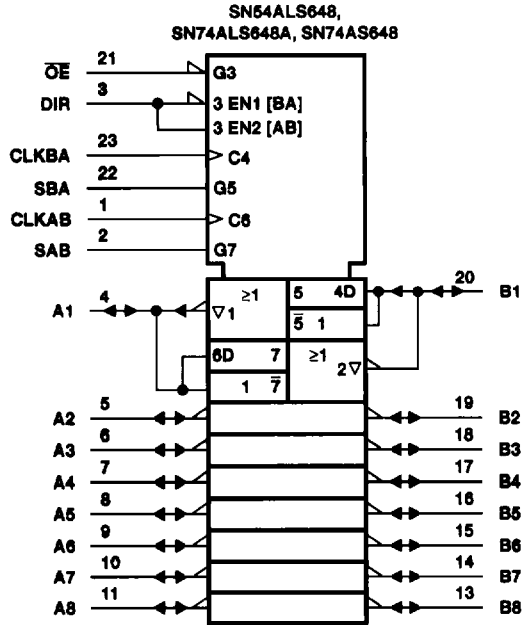
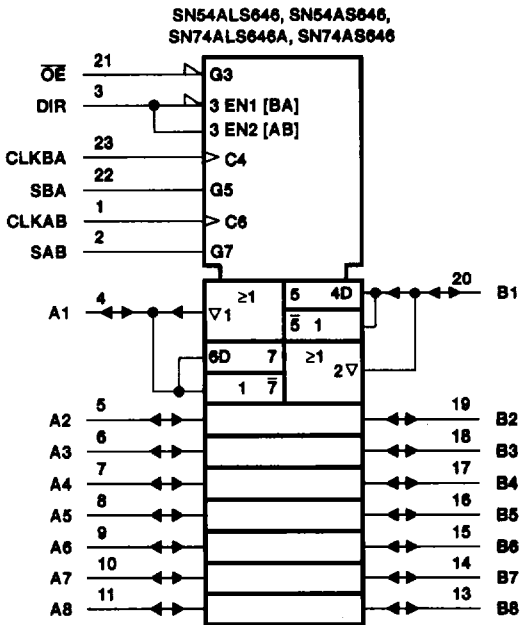

† These symbols are in accordance with ANSI/IEEE Std 91-1984 and IEC Publication 617-12.  
 Pin numbers shown are for the DW, JT, and NT packages.



**SN54ALS646, SN54ALS648, SN54AS646  
SN74ALS646A, SN74ALS648A, SN74AS646, SN74AS648**

SDAS039F - DECEMBER 1983 - REVISED JANUARY 1995

logic diagrams (positive logic)

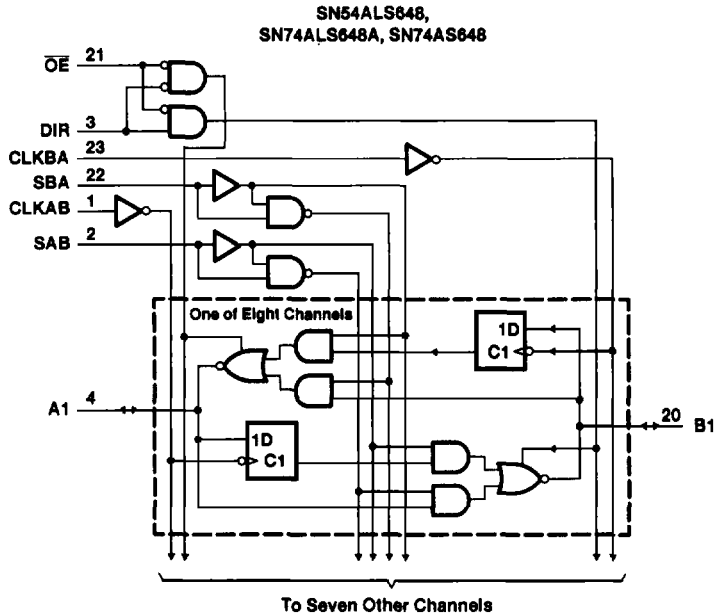
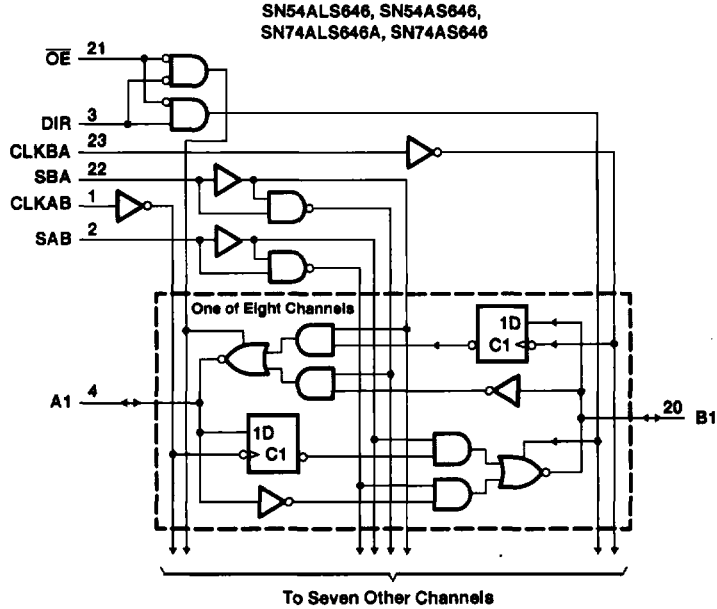

Pin numbers shown are for the DW, JT, and NT packages.



POST OFFICE BOX 655303 • DALLAS, TEXAS 75265



**SN54ALS646, SN54ALS648, SN54AS646  
SN74ALS646A, SN74ALS648A, SN74AS646, SN74AS648  
OCTAL BUS TRANSCEIVERS AND REGISTERS WITH 3-STATE OUTPUTS**

SDAS039F - DECEMBER 1983 - REVISED JANUARY 1995

electrical characteristics over recommended operating free-air temperature range (unless otherwise noted)

PARAMETER	TEST CONDITIONS	SN54ALS646		SN74ALS646A		UNIT	
		MIN	TYP†	MAX	MIN		TYP†
$V_{IK}$	$V_{CC} = 4.5 \text{ V}$ , $I_I = -18 \text{ mA}$			-1.2		-1.2	V
$V_{OH}$	$V_{CC} = 4.5 \text{ V to } 5.5 \text{ V}$ , $I_{OH} = -0.4 \text{ mA}$	$V_{CC}-2$		$V_{CC}-2$		V	
	$V_{CC} = 4.5 \text{ V}$	$I_{OH} = -3 \text{ mA}$	2.4	3.2	2.4		3.2
		$I_{OH} = -12 \text{ mA}$	2				
		$I_{OH} = -15 \text{ mA}$			2		
$V_{OL}$	$V_{CC} = 4.5 \text{ V}$	$I_{OL} = 12 \text{ mA}$	0.25	0.4	0.25	0.4	V
		$I_{OL} = 24 \text{ mA}$			0.35	0.5	
		$I_{OL} = 48 \text{ mA}^\ddagger$			0.35	0.5	
$I_I$	Control inputs	$V_{CC} = 5.5 \text{ V}$	$V_I = 7 \text{ V}$	0.1		0.1	mA
	A or B ports		$V_I = 5.5 \text{ V}$	0.1		0.1	
$I_{IH}$	Control inputs	$V_{CC} = 5.5 \text{ V}$ , $V_I = 2.7 \text{ V}$	20		20		$\mu\text{A}$
	A or B ports§		20		20		
$I_{IL}$	Control inputs	$V_{CC} = 5.5 \text{ V}$ , $V_I = 0.4 \text{ V}$	-0.2		-0.2		mA
	A or B ports§		-0.2		-0.2		
$I_O^\S$	$V_{CC} = 5.5 \text{ V}$ , $V_O = 2.25 \text{ V}$	-20	-112	-30	-112	mA	
$I_{CC}$	$V_{CC} = 5.5 \text{ V}$	Outputs high	47	76	47	76	mA
		Outputs low	55	88	55	88	
		Outputs disabled	55	88	55	88	

† All typical values are at  $V_{CC} = 5 \text{ V}$ ,  $T_A = 25^\circ\text{C}$ .

‡ Applies only to the -1 version and only if  $V_{CC}$  is maintained between 4.75 V and 5.25 V.

§ For I/O ports, the parameters  $I_{IH}$  and  $I_{IL}$  include the off-state output current.

¶ The output conditions have been chosen to produce a current that closely approximates one half of the true short-circuit output current,  $I_{OS}$ .



POST OFFICE BOX 655303 • DALLAS, TEXAS 75265

**SN54ALS646, SN54ALS648, SN54AS646**  
**SN74ALS646A, SN74ALS648A, SN74AS646, SN74AS648**  
**OCTAL BUS TRANSCEIVERS AND REGISTERS WITH 3-STATE OUTPUTS**

SDAS039F - DECEMBER 1983 - REVISED JANUARY 1995

**switching characteristics (see Figure 2)**

PARAMETER	FROM (INPUT)	TO (OUTPUT)	V <sub>CC</sub> = 4.5 V to 5.5 V, C <sub>L</sub> = 50 pF, R <sub>1</sub> = 500 Ω, R <sub>2</sub> = 500 Ω, T <sub>A</sub> = MIN to MAX†				UNIT
			SN54ALS646		SN74ALS646A		
			MIN	MAX	MIN	MAX	
t <sub>max</sub>			35		40	MHz	
t <sub>PLH</sub>	CLKBA or CLKAB	A or B	10	35	7	30	ns
t <sub>PHL</sub>			5	20	5	17	
t <sub>PLH</sub>	A or B	B or A	5	22	3	20	ns
t <sub>PHL</sub>			3	15	3	12	
t <sub>PLH</sub>	SBA or SAB‡ (stored data low)	A or B	10	40	7	35	ns
t <sub>PHL</sub>			5	23	5	20	
t <sub>PLH</sub>	SBA or SAB‡ (stored data high)	A or B	8	30	6	25	ns
t <sub>PHL</sub>			5	24	5	20	
t <sub>PZH</sub>	OE	A or B	3	20	2	17	ns
t <sub>PZL</sub>			5	22	4	20	
t <sub>PHZ</sub>	OE	A or B	1	12	1	10	ns
t <sub>PLZ</sub>			1	20	2	16	
t <sub>PZH</sub>	DIR	A or B	5	38	3	30	ns
t <sub>PZL</sub>			5	30	4	25	
t <sub>PHZ</sub>	DIR	A or B	1	12	1	10	ns
t <sub>PLZ</sub>			2	21	2	16	

† For conditions shown MIN or MAX, use the appropriate value specified under recommended operating conditions.

‡ These parameters are measured with the internal output state of the storage register opposite that of the bus input.



POST OFFICE BOX 655303 • DALLAS, TEXAS 75265



**SN54ALS646, SN54ALS648, SN54AS646  
SN74ALS646A, SN74ALS648A, SN74AS646, SN74AS648**  
**OCTAL BUS TRANSCEIVERS AND REGISTERS WITH 3-STATE OUTPUTS**

SDAS039F - DECEMBER 1983 - REVISED JANUARY 1985

**absolute maximum ratings over operating free-air temperature range (unless otherwise noted)†**

Supply voltage, $V_{CC}$ .....	7 V
Input voltage, $V_I$ : Control inputs .....	7 V
I/O ports .....	5.5 V
Operating free-air temperature range, $T_A$ : SN54ALS648 .....	-55°C to 125°C
SN74ALS648A .....	0°C to 70°C
Storage temperature range .....	-65°C to 150°C

† Stresses beyond those listed under "absolute maximum ratings" may cause permanent damage to the device. These are stress ratings only, and functional operation of the device at these or any other conditions beyond those indicated under "recommended operating conditions" is not implied. Exposure to absolute-maximum-rated conditions for extended periods may affect device reliability.

**recommended operating conditions**

		SN54ALS648			SN74ALS648A			UNIT
		MIN	NOM	MAX	MIN	NOM	MAX	
$V_{CC}$	Supply voltage	4.5	5	5.5	4.5	5	5.5	V
$V_{IH}$	High-level input voltage	2			2			V
$V_{IL}$	Low-level input voltage			0.7			0.8	V
$I_{OH}$	High-level output current			-12			-15	mA
$I_{OL}$	Low-level output current			12			24	mA
$f_{clock}$	Clock frequency		0	35		0	40	MHz
$t_w$	Pulse duration, CLKBA or CLKAB high or low		14.5			12.5		ns
$t_{su}$	Setup time, A before CLKAB↑ or B before CLKBA↑		15			10		ns
$t_h$	Hold time, A after CLKAB↑ or B after CLKBA↑		0			0		ns
$T_A$	Operating free-air temperature		-55	125		0	70	°C



POST OFFICE BOX 655303 • DALLAS, TEXAS 75265

**SN54ALS646, SN54ALS648, SN54AS646**  
**SN74ALS646A, SN74ALS648A, SN74AS646, SN74AS648**  
**OCTAL BUS TRANSCEIVERS AND REGISTERS WITH 3-STATE OUTPUTS**

SDAS039F - DECEMBER 1983 - REVISED JANUARY 1985

**electrical characteristics over recommended operating free-air temperature range (unless otherwise noted)**

PARAMETER	TEST CONDITIONS		SN54ALS648			SN74ALS648A			UNIT
			MIN	TYP†	MAX	MIN	TYP†	MAX	
$V_{IK}$	$V_{CC} = 4.5\text{ V}$ , $I_I = -18\text{ mA}$		-1.2			-1.2			V
$V_{OH}$	$V_{CC} = 4.5\text{ V to }5.5\text{ V}$ , $I_{OH} = -0.4\text{ mA}$		$V_{CC}-2$			$V_{CC}-2$			V
	$V_{CC} = 4.5\text{ V}$	$I_{OH} = -3\text{ mA}$	2.4	3.2		2.4	3.2		
		$I_{OH} = -12\text{ mA}$	2						
$V_{OL}$	$V_{CC} = 4.5\text{ V}$	$I_{OL} = 12\text{ mA}$	0.25	0.4		0.25	0.4	V	
		$I_{OL} = 24\text{ mA}$			0.35		0.5		
$I_I$	Control inputs	$V_{CC} = 5.5\text{ V}$	$V_I = 7\text{ V}$			$V_I = 7\text{ V}$			mA
	A or B ports		$V_I = 5.5\text{ V}$			$V_I = 5.5\text{ V}$			
$I_{IH}$	Control inputs	$V_{CC} = 5.5\text{ V}$ , $V_I = 2.7\text{ V}$	20			20			$\mu\text{A}$
	A or B ports‡		20			20			
$I_{IL}$	Control inputs	$V_{CC} = 5.5\text{ V}$ , $V_I = 0.4\text{ V}$	-0.2			-0.2			mA
	A or B ports‡		-0.2			-0.2			
$I_{OS}§$	$V_{CC} = 5.5\text{ V}$ , $V_O = 2.25\text{ V}$		-20	-112		-30	-112	mA	
$I_{CC}$	$V_{CC} = 5.5\text{ V}$	Outputs high	47	76		47	76	mA	
		Outputs low	57	88		57	88		
		Outputs disabled	57	88		57	88		

† All typical values are at  $V_{CC} = 5\text{ V}$ ,  $T_A = 25^\circ\text{C}$ .

‡ For I/O ports, the parameters  $I_{IH}$  and  $I_{IL}$  include the off-state output current.

§ The output conditions have been chosen to produce a current that closely approximates one half of the true short-circuit output current,  $I_{OS}$ .



**SN54ALS646, SN54ALS648, SN54AS646**  
**SN74ALS646A, SN74ALS648A, SN74AS646, SN74AS648**  
**OCTAL BUS TRANSCEIVERS AND REGISTERS WITH 3-STATE OUTPUTS**

SDAS039F - DECEMBER 1983 - REVISED JANUARY 1995

**switching characteristics (see Figure 2)**

PARAMETER	FROM (INPUT)	TO (OUTPUT)	V <sub>CC</sub> = 4.5 V to 5.5 V, C <sub>L</sub> = 50 pF, R <sub>1</sub> = 500 Ω, R <sub>2</sub> = 500 Ω, T <sub>A</sub> = MIN to MAX†				UNIT
			SN54ALS646		SN74ALS648A		
			MIN	MAX	MIN	MAX	
f <sub>max</sub>			35		40		MHz
t <sub>PLH</sub>	CLKBA or CLKAB	A or B	8	39	7	33	ns
t <sub>PHL</sub>			5	23	5	20	
t <sub>PLH</sub>	A or B	B or A	3	20	2	17	ns
t <sub>PHL</sub>			2	12	2	10	
t <sub>PLH</sub>	SBA or SAB‡ (stored data low)	A or B	5	44	5	39	ns
t <sub>PHL</sub>			4	26	4	22	
t <sub>PLH</sub>	SBA or SAB‡ (stored data high)	A or B	6	30	6	25	ns
t <sub>PHL</sub>			6	25	6	21	
t <sub>PZH</sub>	OE	A or B	4	25	2	22	ns
t <sub>PZL</sub>			4	25	4	22	
t <sub>PHZ</sub>	OE	A or B	1	12	1	10	ns
t <sub>PLZ</sub>			2	21	2	15	
t <sub>PZH</sub>	DIR	A or B	4	35	2	27	ns
t <sub>PZL</sub>			3	25	3	19	
t <sub>PHZ</sub>	DIR	A or B	1	17	1	14	ns
t <sub>PLZ</sub>			2	22	2	15	

† For conditions shown MIN or MAX, use the appropriate value specified under recommended operating conditions.

‡ These parameters are measured with the internal output state of the storage register opposite that of the bus input.



**SN54ALS646, SN54ALS648, SN54AS646**  
**SN74ALS646A, SN74ALS648A, SN74AS646, SN74AS648**  
**OCTAL BUS TRANSCEIVERS AND REGISTERS WITH 3-STATE OUTPUTS**  
SDAS039F - DECEMBER 1983 - REVISED JANUARY 1985

**absolute maximum ratings over operating free-air temperature range (unless otherwise noted)†**

Supply voltage, $V_{CC}$ .....	7 V
Input voltage, $V_I$ : Control inputs .....	7 V
I/O ports .....	5.5 V
Operating free-air temperature range, $T_A$ : SN54AS646 .....	-55°C to 125°C
SN74AS646 .....	0°C to 70°C
Storage temperature range .....	-65°C to 150°C

† Stresses beyond those listed under "absolute maximum ratings" may cause permanent damage to the device. These are stress ratings only, and functional operation of the device at these or any other conditions beyond those indicated under "recommended operating conditions" is not implied. Exposure to absolute-maximum-rated conditions for extended periods may affect device reliability.

**recommended operating conditions**

	SN54AS646			SN74AS646			UNIT
	MIN	NOM	MAX	MIN	NOM	MAX	
$V_{CC}$ Supply voltage	4.5	5	5.5	4.5	5	5.5	V
$V_{IH}$ High-level input voltage	2			2			V
$V_{IL}$ Low-level input voltage			0.8			0.8	V
$I_{OH}$ High-level output current			-12			-15	mA
$I_{OL}$ Low-level output current			32			48	mA
$f_{clock}^*$ Clock frequency	0		75	0		90	MHz
$t_w^*$ Pulse duration	CLKBA or CLKAB high		6	CLKBA or CLKAB low		5	ns
	CLKBA or CLKAB low		7	CLKBA or CLKAB high		6	
$t_{su}^*$ Setup time, A before CLKAB↑ or B before CLKBA↑			7			6	ns
$t_h^*$ Hold time, A after CLKAB↑ or B before CLKBA			0			0	ns
$T_A$ Operating free-air temperature			-55			125	°C

\* On products compliant to MIL-STD-883, Class B, this parameter is based on characterization data but is not production tested.



**SN54ALS646, SN54ALS648, SN54AS646  
SN74ALS646A, SN74ALS648A, SN74AS646, SN74AS648  
OCTAL BUS TRANSCEIVERS AND REGISTERS WITH 3-STATE OUTPUTS**

SDAS039F - DECEMBER 1983 - REVISED JANUARY 1995

electrical characteristics over recommended operating free-air temperature range (unless otherwise noted)

PARAMETER	TEST CONDITIONS		SN54AS646		SN74AS646		UNIT
			MIN	TYP†	MAX	MIN	
$V_{IK}$	$V_{CC} = 4.5\text{ V}$ , $I_I = -18\text{ mA}$				-1.2		V
$V_{OH}$	$V_{CC} = 4.5\text{ V to }5.5\text{ V}$ , $I_{OH} = -2\text{ mA}$		$V_{CC}-2$		$V_{CC}-2$		V
	$V_{CC} = 4.5\text{ V}$	$I_{OH} = -3\text{ mA}$	2.4	3.2	2.4	3.2	
		$I_{OH} = -12\text{ mA}$	2				
		$I_{OH} = -15\text{ mA}$			2		
$V_{OL}$	$V_{CC} = 4.5\text{ V}$	$I_{OL} = 32\text{ mA}$	0.25	0.5			V
		$I_{OL} = 48\text{ mA}$			0.35	0.5	
$I_I$	Control inputs	$V_{CC} = 5.5\text{ V}$ , $V_I = 7\text{ V}$			0.1	0.1	mA
	A or B ports	$V_{CC} = 5.5\text{ V}$ , $V_I = 5.5\text{ V}$			0.1	0.1	
$I_{IH}$	Control inputs	$V_{CC} = 5.5\text{ V}$ , $V_I = 2.7\text{ V}$			20	20	$\mu\text{A}$
	A or B ports‡				70	70	
$I_{IL}$	Control input	$V_{CC} = 5.5\text{ V}$ , $V_I = 0.4\text{ V}$			-0.5	-0.5	mA
	A or B ports‡				-0.75	-0.75	
$I_{OS}$ §	$V_{CC} = 5.5\text{ V}$ , $V_O = 2.25\text{ V}$		-30	-112	-30	-112	mA
$I_{CC}$	$V_{CC} = 5.5\text{ V}$	Outputs high	120	195	120	195	mA
		Outputs low	130	211	130	211	
		Outputs disabled	130	211	130	211	

† All typical values are at  $V_{CC} = 5\text{ V}$ ,  $T_A = 25\text{ }^\circ\text{C}$ .

‡ For I/O ports, the parameters  $I_{IH}$  and  $I_{IL}$  include the off-state output current.

§ The output conditions have been chosen to produce a current that closely approximates one half of the true short-circuit output current,  $I_{OS}$ .



**SN54ALS646, SN54ALS648, SN54AS646**  
**SN74ALS646A, SN74ALS648A, SN74AS646, SN74AS648**  
**OCTAL BUS TRANSCEIVERS AND REGISTERS WITH 3-STATE OUTPUTS**

SDAS039F - DECEMBER 1983 - REVISED JANUARY 1985

**switching characteristics (see Figure 2)**

PARAMETER	FROM (INPUT)	TO (OUTPUT)	V <sub>CC</sub> = 4.5 V to 5.5 V, C <sub>L</sub> = 50 pF, R <sub>1</sub> = 500 Ω, R <sub>2</sub> = 500 Ω, T <sub>A</sub> = MIN to MAX†				UNIT
			SN54AS646		SN74AS646		
			MIN	MAX	MIN	MAX	
t <sub>max</sub> *			75		90		MHz
t <sub>PLH</sub>	CLKBA or CLKAB	A or B	2	9.5	2	8.5	ns
t <sub>PHL</sub>			2	10	2	9	
t <sub>PLH</sub>	A or B	B or A	2	11.5	2	9	ns
t <sub>PHL</sub>			1	8	1	7	
t <sub>PLH</sub>	SBA or SAB‡	A or B	2	13.5	2	11	ns
t <sub>PHL</sub>			2	11	2	9	
t <sub>PZH</sub>	OE	A or B	2	11	2	9	ns
t <sub>PZL</sub>			3	15	3	14	
t <sub>PHZ</sub>	OE	A or B	2	11	2	9	ns
t <sub>PLZ</sub>			2	11	2	9	
t <sub>PZH</sub>	DIR	A or B	3	21	3	16	ns
t <sub>PZL</sub>			3	24	3	18	
t <sub>PHZ</sub>	DIR	A or B	2	12	2	10	ns
t <sub>PLZ</sub>			2	12	2	10	

\* On products compliant to MIL-STD-883, Class B, this parameter is based on characterization data but is not production tested.

† For conditions shown MIN or MAX, use the appropriate value specified under recommended operating conditions.

‡ These parameters are measured with the internal output state of the storage register opposite that of the bus input.



**SN54ALS646, SN54ALS648, SN54AS646**  
**SN74ALS646A, SN74ALS648A, SN74AS646, SN74AS648**  
**OCTAL BUS TRANSCEIVERS AND REGISTERS WITH 3-STATE OUTPUTS**

SDAS039F - DECEMBER 1983 - REVISED JANUARY 1995

**absolute maximum ratings over operating free-air temperature range (unless otherwise noted)†**

Supply voltage, $V_{CC}$ .....	7 V
Input voltage, $V_I$ : Control inputs .....	7 V
I/O ports .....	5.5 V
Operating free-air temperature range, $T_A$ : SN74AS648 .....	0°C to 70°C
Storage temperature range .....	-65°C to 150°C

† Stresses beyond those listed under "absolute maximum ratings" may cause permanent damage to the device. These are stress ratings only, and functional operation of the device at these or any other conditions beyond those indicated under "recommended operating conditions" is not implied. Exposure to absolute-maximum-rated conditions for extended periods may affect device reliability.

**recommended operating conditions**

		SN74AS648			UNIT
		MIN	NOM	MAX	
$V_{CC}$	Supply voltage	4.5	5	5.5	V
$V_{IH}$	High-level input voltage	2			V
$V_{IL}$	Low-level input voltage			0.8	V
$I_{OH}$	High-level output current			-15	mA
$I_{OL}$	Low-level output current			48	mA
$f_{clock}$	Clock frequency	0		90	MHz
$t_w$	Pulse duration	CLKBA or CLKAB high	5		ns
		CLKBA or CLKAB low	6		
$t_{su}$	Setup time, A before CLKAB↑ or B before CLKBA↑	6			ns
$t_h$	Hold time, A after CLKAB↑ or B before CLKBA	0			ns
$T_A$	Operating free-air temperature	0		70	°C

**electrical characteristics over recommended operating free-air temperature range (unless otherwise noted)**

PARAMETER		TEST CONDITIONS		SN74AS648			UNIT
				MIN	TYP‡	MAX	
$V_{IK}$		$V_{CC} = 4.5 V$ ,	$I_I = -18 mA$			-1.2	V
$V_{OH}$		$V_{CC} = 4.5 V$ to $5.5 V$ , $I_{OH} = -2 mA$		$V_{CC}-2$			V
		$V_{CC} = 4.5 V$	$I_{OH} = -3 mA$	2.4	3.2		
			$I_{OH} = -15 mA$	2			
$V_{OL}$		$V_{CC} = 4.5 V$ ,	$I_{OL} = 48 mA$	0.35	0.5		V
$I_I$	Control inputs	$V_{CC} = 5.5 V$	$V_I = 7 V$			0.1	mA
	A or B ports		$V_I = 5.5 V$			0.1	
$I_{IH}$	Control inputs	$V_{CC} = 5.5 V$ ,	$V_I = 2.7 V$			20	$\mu A$
	A or B ports§					70	
$I_{IL}$	Control input	$V_{CC} = 5.5 V$ ,	$V_I = 0.4 V$			-0.5	mA
	A or B ports§					-0.75	
$I_O^¶$		$V_{CC} = 5.5 V$ ,	$V_O = 2.25 V$	-30		-112	mA
$I_{CC}$		$V_{CC} = 5.5 V$	Outputs high		110	185	mA
			Outputs low		120	195	
			Outputs disabled		120	195	

‡ All typical values are at  $V_{CC} = 5 V$ ,  $T_A = 25 ^\circ C$ .

§ For I/O ports, the parameters  $I_{IH}$  and  $I_{IL}$  include the off-state output current.

¶ The output conditions have been chosen to produce a current that closely approximates one half of the true short-circuit output current,  $I_{OS}$ .



**SN54ALS646, SN54ALS648, SN54AS646**  
**SN74ALS646A, SN74ALS648A, SN74AS646, SN74AS648**  
**OCTAL BUS TRANSCEIVERS AND REGISTERS WITH 3-STATE OUTPUTS**  
SDAS039F – DECEMBER 1983 – REVISED JANUARY 1995

**switching characteristics (see Figure 2)**

PARAMETER	FROM (INPUT)	TO (OUTPUT)	V <sub>CC</sub> = 4.5 V to 5.5 V, C <sub>L</sub> = 50 pF, R <sub>1</sub> = 500 Ω, R <sub>2</sub> = 500 Ω, T <sub>A</sub> = MIN to MAX†		UNIT
			SN74AS648		
			MIN	MAX	
t <sub>max</sub>			90		MHz
t <sub>PLH</sub>	CLKBA or CLKAB	A or B	2	8.5	ns
t <sub>PHL</sub>			2	9	
t <sub>PLH</sub>	A or B	B or A	2	8	ns
t <sub>PHL</sub>			1	7	
t <sub>PLH</sub>	SBA or SAB‡	A or B	2	11	ns
t <sub>PHL</sub>			2	9	
t <sub>PZH</sub>	OE	A or B	2	9	ns
t <sub>PZL</sub>			3	15	
t <sub>PHZ</sub>	OE	A or B	2	9	ns
t <sub>PLZ</sub>			2	9	
t <sub>PZH</sub>	DIR	A or B	3	16	ns
t <sub>PZL</sub>			3	18	
t <sub>PHZ</sub>	DIR	A or B	2	10	ns
t <sub>PLZ</sub>			2	10	

† For conditions shown MIN or MAX, use the appropriate value specified under recommended operating conditions.  
‡ These parameters are measured with the internal output state of the storage register opposite that of the bus input.





**SN54ALS646, SN54ALS648, SN54AS646  
SN74ALS646A, SN74ALS648A, SN74AS646, SN74AS648**  
**OCTAL BUS TRANSCEIVERS AND REGISTERS WITH 3-STATE OUTPUTS**

SDAS039F - DECEMBER 1983 - REVISED JANUARY 1995

**PARAMETER MEASUREMENT INFORMATION**

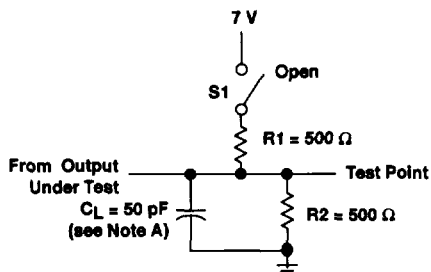

**LOAD CIRCUIT  
FOR 3-STATE OUTPUTS**

**SWITCH POSITION TABLE**

TEST	S1
tPLH	Open
tPHL	Open
tPZH	Open
tPZL	Closed
tPHZ	Open
tPLZ	Closed

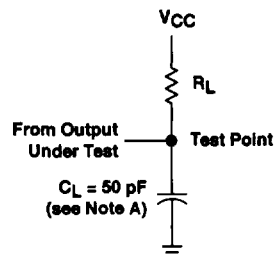

**LOAD CIRCUIT  
FOR OPEN-COLLECTOR OUTPUTS**

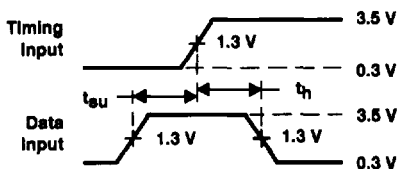

**VOLTAGE WAVEFORMS  
SETUP AND HOLD TIMES**

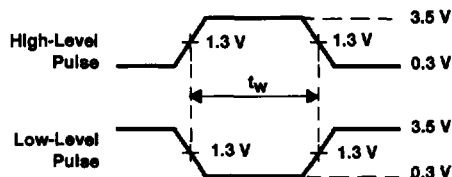

**VOLTAGE WAVEFORMS  
PULSE DURATION**

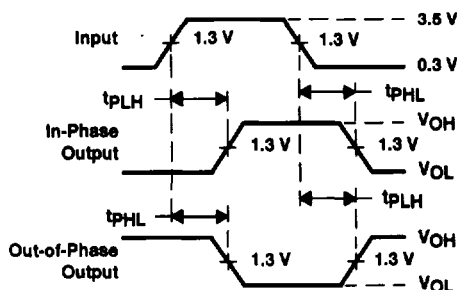

**VOLTAGE WAVEFORMS  
PROPAGATION DELAY TIMES**

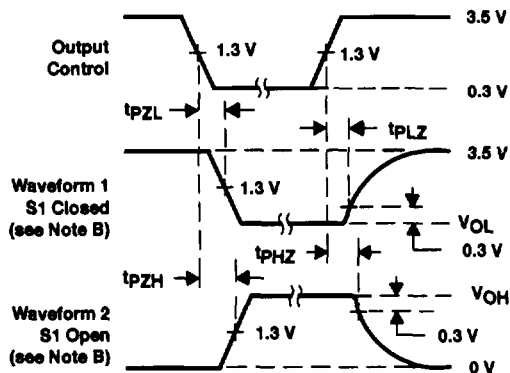

**VOLTAGE WAVEFORMS  
ENABLE AND DISABLE TIMES, 3-STATE OUTPUTS**

- NOTES: A.  $C_L$  includes probe and jig capacitance.  
 B. Waveform 1 is for an output with internal conditions such that the output is low except when disabled by the output control. Waveform 2 is for an output with internal conditions such that the output is high except when disabled by the output control.  
 C. All input pulses are supplied by generators having the following characteristics:  $PRR \leq 1$  MHz,  $Z_O = 50 \Omega$ ,  $t_r \leq 2$  ns,  $t_f \leq 2$  ns.  
 D. The outputs are measured one at a time with one transition per measurement.

**Figure 2. Load Circuits and Voltage Waveforms**



POST OFFICE BOX 655303 • DALLAS, TEXAS 75265