

DO NOT SCALE FROM THIS PRINTS

FIG 1

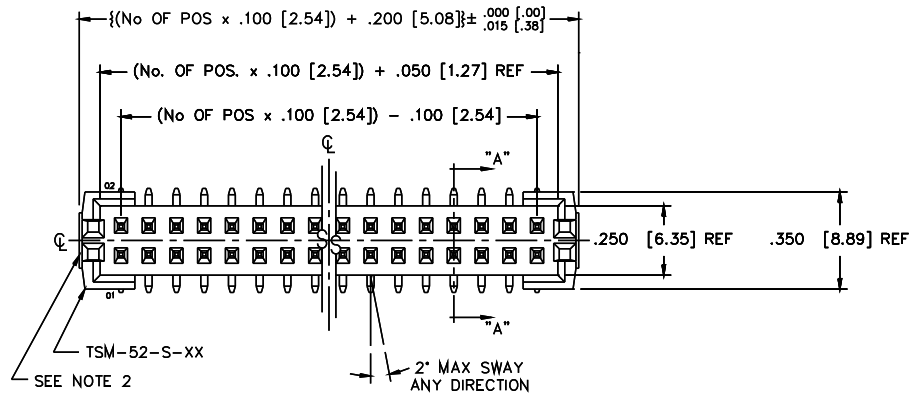

TSSH-1XX-01-XX-XX-XX

NO. OF POSITIONS
-05 THRU -36 (PER ROW)
LEAD STYLE
-01

- PLATING
- S: 30μ" SELECTIVE GOLD IN CONTACT AREA, MATTE TIN ON TAIL
 - F: 3μ" FLASH SELECTIVE GOLD IN CONTACT AREA, MATTE TIN ON TAIL
 - L: 10μ" LIGHT SELECTIVE GOLD IN CONTACT AREA, MATTE TIN ON TAIL
 - T: MATTE TIN CONTACT AND TAIL
 - G: 10μ" LIGHT GOLD IN CONTACT AREA, 3μ" ON TAIL
 - H: 30μ" HEAVY GOLD IN CONTACT AREA, 3μ" ON TAIL
 - TM: MATTE TIN CONTACT AND TAIL
 - SM: 30μ" SELECTIVE GOLD IN CONTACT AREA, MATTE TIN ON TAIL
 - LM: 10μ" LIGHT SELECTIVE GOLD IN CONTACT AREA, MATTE TIN ON TAIL
 - FM: 3μ" FLASH SELECTIVE GOLD IN CONTACT AREA, MATTE TIN ON TAIL
 - STL: 30μ" SELECTIVE GOLD IN CONTACT AREA, TIN/LEAD (90%/10 +/ -5%) TAIL

- OPTION 2
- LC: LOCKING CLIP (SEE FIG. 1)(SEE NOTE 5)(DV ONLY)
 - A: ALIGNMENT PIN (SEE FIG. 2, SHEET 2) (DV ONLY)
 - P: PICK & PLACE PAD USE PPP-06 (SEE FIG. 4) (DV ONLY)
 - *-M: METAL PICK & PLACE PAD USE LMP-01 (SEE FIG. 5) (DV ONLY)
 - TR: TAPE & REEL (-05 THRU -28 POS) (DV ONLY)
- OPTION 1
POLARIZED POSITIONS
SPECIFY OMITTED PINS

ROW SPECIFICATION
-DV: DOUBLE VERTICAL
-D: THROUGH HOLE

COPLANARITY	
POSITION	
05-10	.004
11-24	.006
25-36	.008

* FOR EXISTING CUSTOMERS ONLY

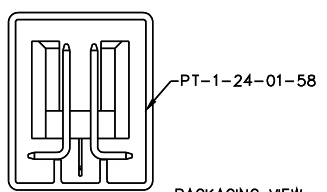
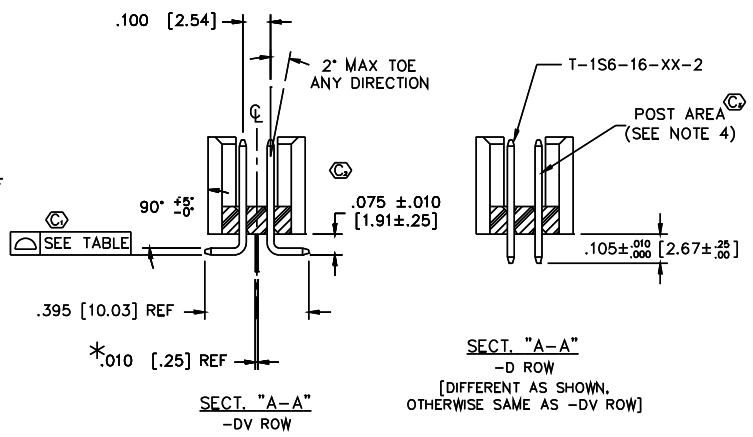
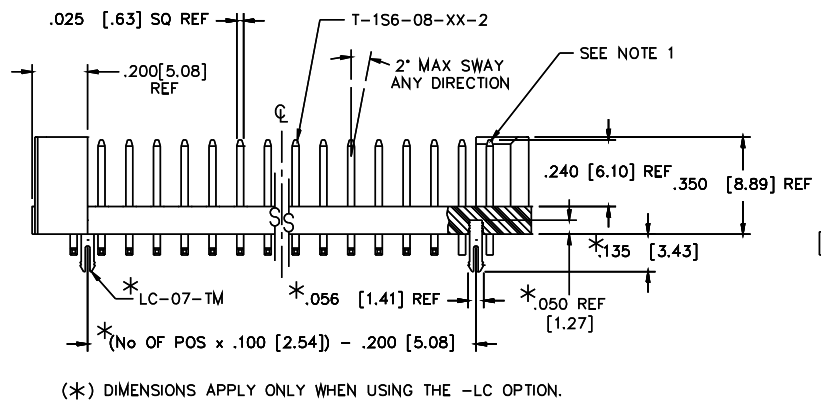

PACKAGING VIEW (SEE NOTE 2)

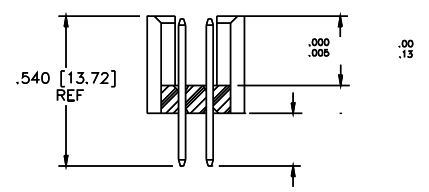

IN-PROCESS (DV ONLY)

- NOTE:
1. MAXIMUM CUT FLASH ALLOWED IS .010" IN THIS AREA ONLY.
 2. PACKAGE IN PT-1-24-01-58 TUBE WITH TWO TP-13 PLUGS PER TUBE.
 3. Ⓞ REPRESENTS A CRITICAL DIMENSION.
 4. FILL -T PLATED PINS THE SAME AS SELECTIVE TO REDUCE BANDOLIER MARKS IN THE POST AREA.
 5. DUE TO THE HIGH AMOUNT OF INSERTION FORCE NEEDED, THE -LC OPTION IS NOT COMPATIBLE WITH AUTO PLACEMENT. SAMTEC RECOMMENDS MANUAL PLACEMENT FOR ALL ASSEMBLIES WITH THE -LC OPTION.
 6. INSULATOR MATERIAL: BLACK, LCP, UL 94 VO

PROPRIETARY NOTE
THIS DOCUMENT CONTAINS INFORMATION CONFIDENTIAL AND PROPRIETARY TO SAMTEC INC. AND SHALL NOT BE REPRODUCED OR TRANSMITTED IN ANY FORM OR BY ANY MEANS, ELECTRONIC OR MECHANICAL, INCLUDING PHOTOCOPYING, RECORDING, OR BY ANY INFORMATION STORAGE AND RETRIEVAL SYSTEM, WITHOUT THE EXPRESS WRITTEN CONSENT OF SAMTEC INC.

EXPSPROD/ASSEMBLY/100
 TSSH-ES1
 520 PARK EAST BLVD., NEW ALBANY, INDIANA 47150
 PHONE (812) 944-6733 P.O. BOX 1147
 CODE 55322
 MADE BY: BRATCHER 10-30-97
 TSSH-1XX-01-XX-XX-XX
 SHEET 1 OF 2