

DRAWING FOR REFERENCE: This is subject to change without notice
08/11/2012

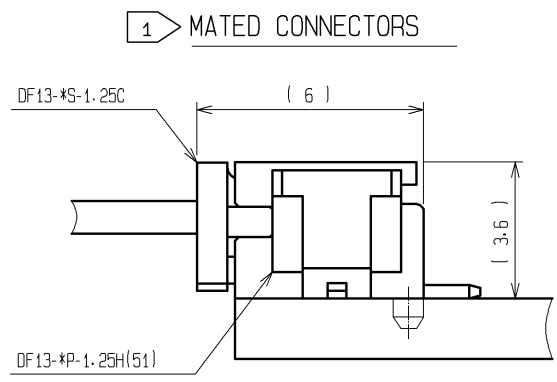

CODE No.	PARTS No.	NUMBER OF CONTACT	A	B	C	D	E	F
CL536-0251-1-51	DF13- 2P-1.25H(51)	2	1.25	3.15	4.15	7.15	3.35	5.65
CL536-0252-4-51	DF13- 3P-1.25H(51)	3	2.5	4.4	5.4	8.4	4.60	6.9
CL536-0253-7-51	DF13- 4P-1.25H(51)	4	3.75	5.65	6.65	9.65	5.85	8.15
CL536-0254-0-51	DF13- 5P-1.25H(51)	5	5.0	6.9	7.9	10.9	7.10	9.40
CL536-0255-2-51	DF13- 6P-1.25H(51)	6	6.25	8.15	9.15	12.15	8.35	10.65
CL536-0256-5-51	DF13- 7P-1.25H(51)	7	7.5	9.4	10.4	13.4	9.60	11.9
CL536-0257-8-51	DF13- 8P-1.25H(51)	8	8.75	10.65	11.65	14.65	10.85	13.15
CL536-0258-0-51	DF13- 9P-1.25H(51)	9	10.0	11.9	12.9	15.9	12.1	14.4
CL536-0259-3-51	DF13-10P-1.25H(51)	10	11.25	13.15	14.15	17.15	13.35	15.65
CL536-0261-5-51	DF13-12P-1.25H(51)	12	13.75	15.65	16.65	19.65	15.85	18.15
CL536-0263-0-51	DF13-14P-1.25H(51)	14	16.25	18.15	19.15	22.15	18.35	20.65
CL536-0264-3-51	DF13-15P-1.25H(51)	15	17.5	19.4	20.4	23.4	19.6	21.9

RECOMMENDED PATTERN

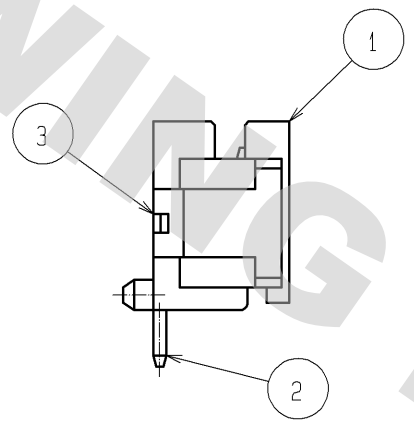
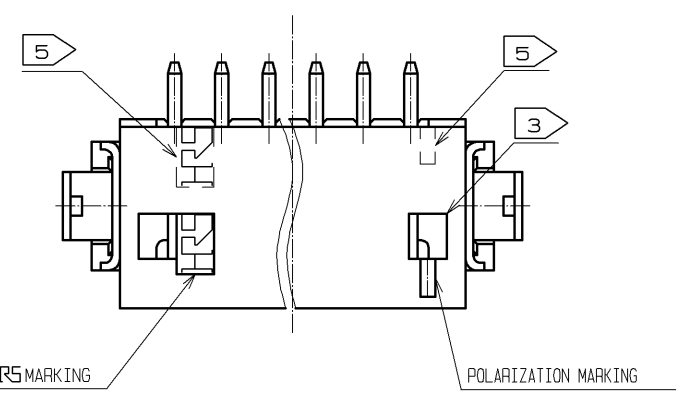
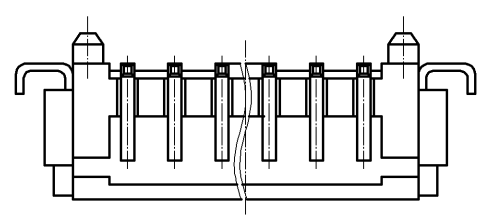
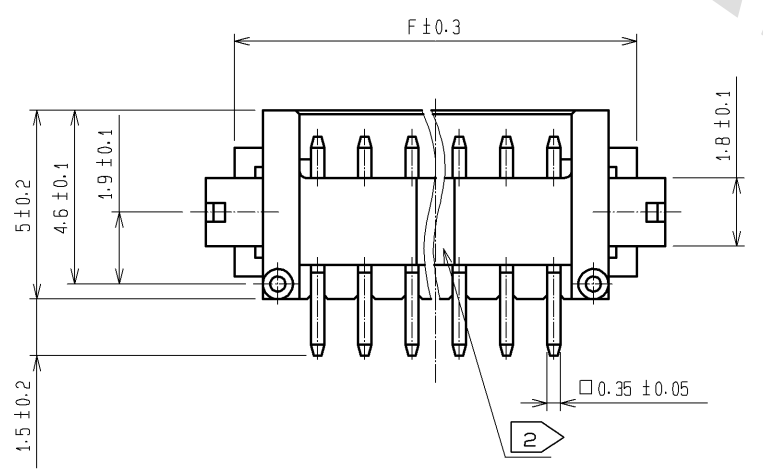
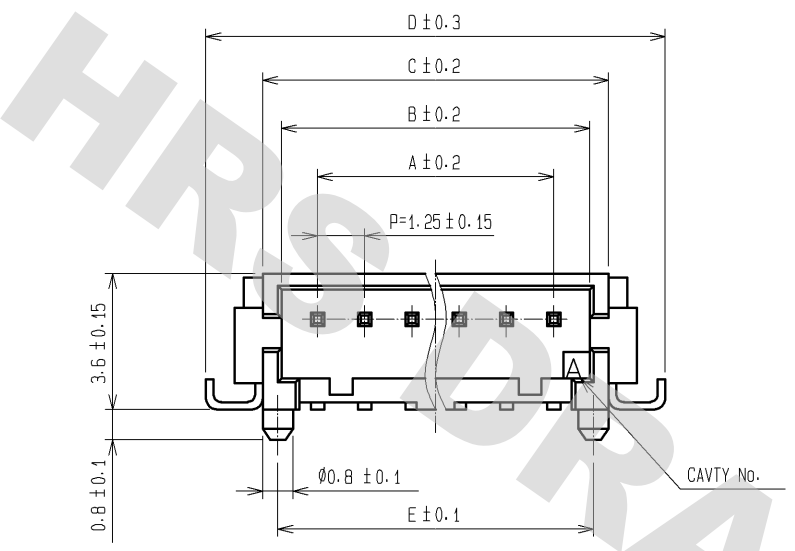
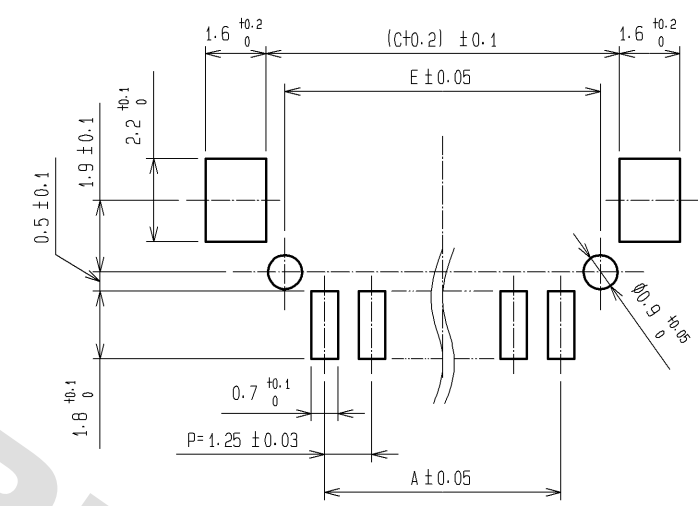

- NOTE
- 1 : WHEN THIS CONNECTOR MATES WITH DF13-*S-1.25C THE MATING LENGTH IS 3.6 mm.
 - 2 : THERE SHALL BE STANDOFF MORE THAN FIVE CONTACTS.
 - 3 : WHEN THIS CONNECTOR HAS TWO OR THREE CONTACTS, THE LOCK SHALL BE SET AT THE CENTER OF HOUSING. IF MORE THAN FOUR, THE TWO LOCKS SHALL BE SET AS SHOWN ON THIS DRAWING.
 - 4 : FLATNESS OF LEAD WITH REINFORCED METAL FITTINGS SHALL BE WITHIN 0.1mm.
 - 5 : WHEN THIS CONNECTOR HAS MORE THAN SEVEN CONTACTS, HRS MARKING AND POLARIZATION MARKING SHIFT TO THE PLACE INDICATING DOTTED LINES.

2	POLYAMIDE	SURFACE:GOLD PLATED 0.2μ m min UNDER:NICKEL PLATED 0.5μ m min	5	POLYESTER	COVER TAPE, CLEAR		
1	POLYAMIDE	BEIGE(NATURAL), UL94V-0	4	PS	EMBOSSED CARRIER TAPE, CLEAR		
			3	PHOSPHOR BRONZE	SURFACE PLATING:TIN PLATED 1μ m min		
NO.	MATERIAL	FINISH, REMARKS	NO.	MATERIAL	FINISH, REMARKS		
UNITS mm		SCALE 5 : 1	COUNT 	DESCRIPTION OF REVISIONS	DESIGNED	CHECKED	DATE
APPROVED : KI. AKIYAMA		10.05.28	DRAWING NO.		EDC3-083662-04		
CHECKED : HK. UMEHARA		10.05.28	PART NO.		DF13-*P-1.25H(51)		
DESIGNED : TS. KUMAZAWA		10.05.28	CODE NO.		CL536-		
DRAWN : MI. SAKIMURA		10.05.21					

DRAWING FOR REFERENCE: This is subject to change without notice
08/11/2012

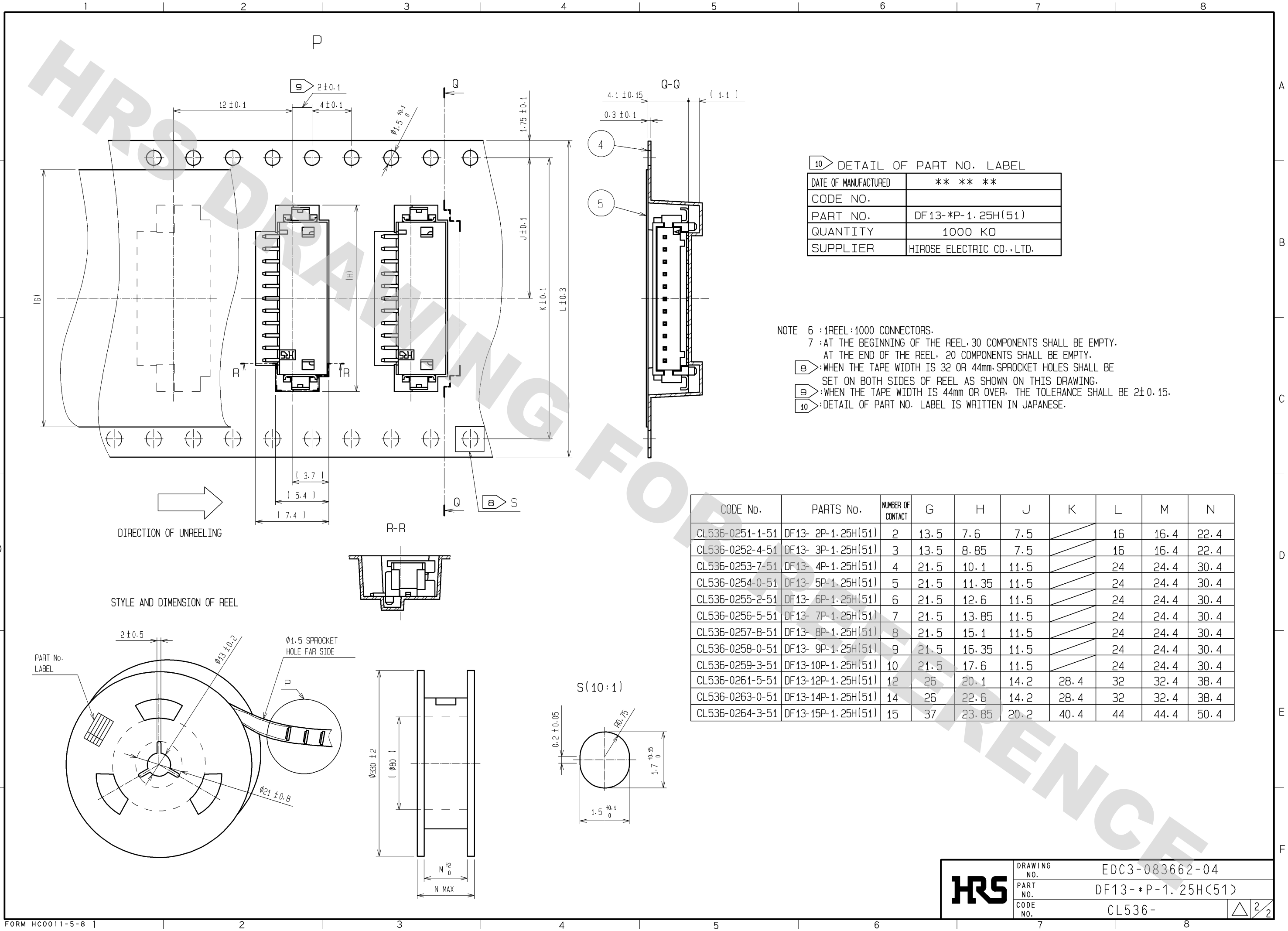

10 DETAIL OF PART NO. LABEL

DATE OF MANUFACTURED	** ** *
CODE NO.	
PART NO.	DF13-*P-1.25H(51)
QUANTITY	1000 KO
SUPPLIER	HIROSE ELECTRIC CO.,LTD.

NOTE 6 : 1 REEL : 1000 CONNECTORS.
 7 : AT THE BEGINNING OF THE REEL, 30 COMPONENTS SHALL BE EMPTY.
 AT THE END OF THE REEL, 20 COMPONENTS SHALL BE EMPTY.
 B : WHEN THE TAPE WIDTH IS 32 OR 44mm, SPROCKET HOLES SHALL BE SET ON BOTH SIDES OF REEL AS SHOWN ON THIS DRAWING.
 9 : WHEN THE TAPE WIDTH IS 44mm OR OVER, THE TOLERANCE SHALL BE 2±0.15.
 10 : DETAIL OF PART NO. LABEL IS WRITTEN IN JAPANESE.

CODE No.	PARTS No.	NUMBER OF CONTACT	G	H	J	K	L	M	N
CL536-0251-1-51	DF13- 2P-1.25H(51)	2	13.5	7.6	7.5		16	16.4	22.4
CL536-0252-4-51	DF13- 3P-1.25H(51)	3	13.5	8.85	7.5		16	16.4	22.4
CL536-0253-7-51	DF13- 4P-1.25H(51)	4	21.5	10.1	11.5		24	24.4	30.4
CL536-0254-0-51	DF13- 5P-1.25H(51)	5	21.5	11.35	11.5		24	24.4	30.4
CL536-0255-2-51	DF13- 6P-1.25H(51)	6	21.5	12.6	11.5		24	24.4	30.4
CL536-0256-5-51	DF13- 7P-1.25H(51)	7	21.5	13.85	11.5		24	24.4	30.4
CL536-0257-8-51	DF13- 8P-1.25H(51)	8	21.5	15.1	11.5		24	24.4	30.4
CL536-0258-0-51	DF13- 9P-1.25H(51)	9	21.5	16.35	11.5		24	24.4	30.4
CL536-0259-3-51	DF13-10P-1.25H(51)	10	21.5	17.6	11.5		24	24.4	30.4
CL536-0261-5-51	DF13-12P-1.25H(51)	12	26	20.1	14.2	28.4	32	32.4	38.4
CL536-0263-0-51	DF13-14P-1.25H(51)	14	26	22.6	14.2	28.4	32	32.4	38.4
CL536-0264-3-51	DF13-15P-1.25H(51)	15	37	23.85	20.2	40.4	44	44.4	50.4

HRS	DRAWING NO.	EDC3-083662-04
	PART NO.	DF13-*P-1.25H(51)
	CODE NO.	CL536-