

LOW POWER QUAD VOLTAGE COMPARATORS

- WIDE SINGLE SUPPLY VOLTAGE RANGE OR DUAL SUPPLIES FOR ALL DEVICES : +2V TO +36V OR $\pm 1V$ TO $\pm 18V$
- VERY LOW SUPPLY CURRENT (1.1mA) INDEPENDENT OF SUPPLY VOLTAGE (1.4mW/comparator at +5V)
- LOW INPUT BIAS CURRENT : 25nA TYP
- LOW INPUT OFFSET CURRENT : $\pm 5nA$ TYP
- LOW INPUT OFFSET VOLTAGE : $\pm 1mV$ TYP
- INPUT COMMON-MODE VOLTAGE RANGE INCLUDES GROUND
- LOW OUTPUT SATURATION VOLTAGE : 250mV TYP. ($I_o = 4mA$)
- DIFFERENTIAL INPUT VOLTAGE RANGE EQUAL TO THE SUPPLY VOLTAGE
- TTL, DTL, ECL, MOS, CMOS COMPATIBLE OUTPUTS

DESCRIPTION

These devices consist of four independent precision voltage comparators with an offset voltage specifications as low as 2mV max for LM339A, LM239A and LM139A. All these comparators were designed specifically to operate from a single power supply over a wide range of voltages. Operation from split power supplies is also possible.

These comparators also have a unique characteristic in that the input common-mode voltage range includes ground even though operated from a single power supply voltage.

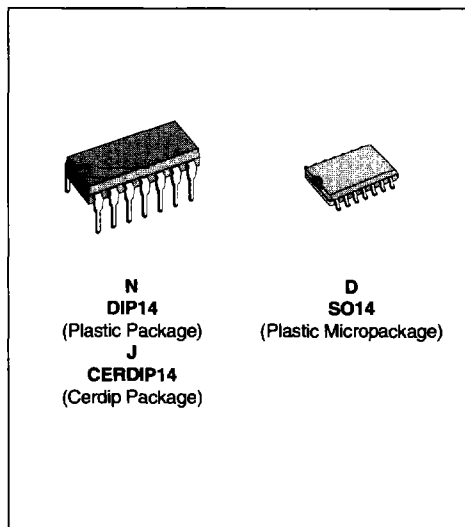

ORDER CODES

| Part Number | Temperature Range | Package | | |
|-------------|-------------------|---------|---|---|
| | | N | J | D |
| LM139/A | -55, +125°C | • | • | • |
| LM239/A | -40, +105°C | • | • | • |
| LM339/A | 0, +70°C | • | • | • |
| LM2901 | -40, +105°C | • | • | • |

Examples : LM139AN, LM2901D

139-01.TBL

PIN CONNECTIONS (top view)

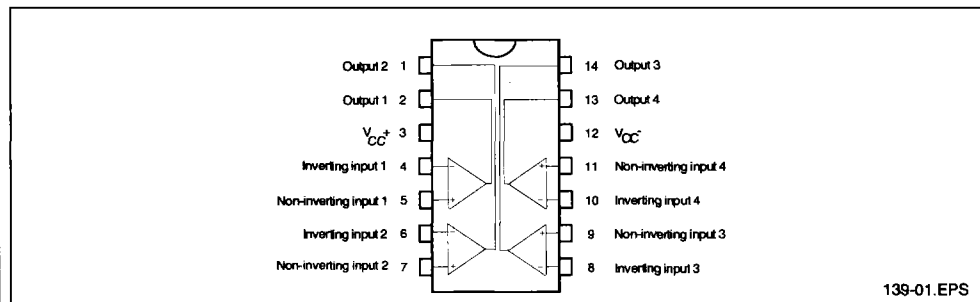

SCHEMATIC DIAGRAM (1/4 LM139)

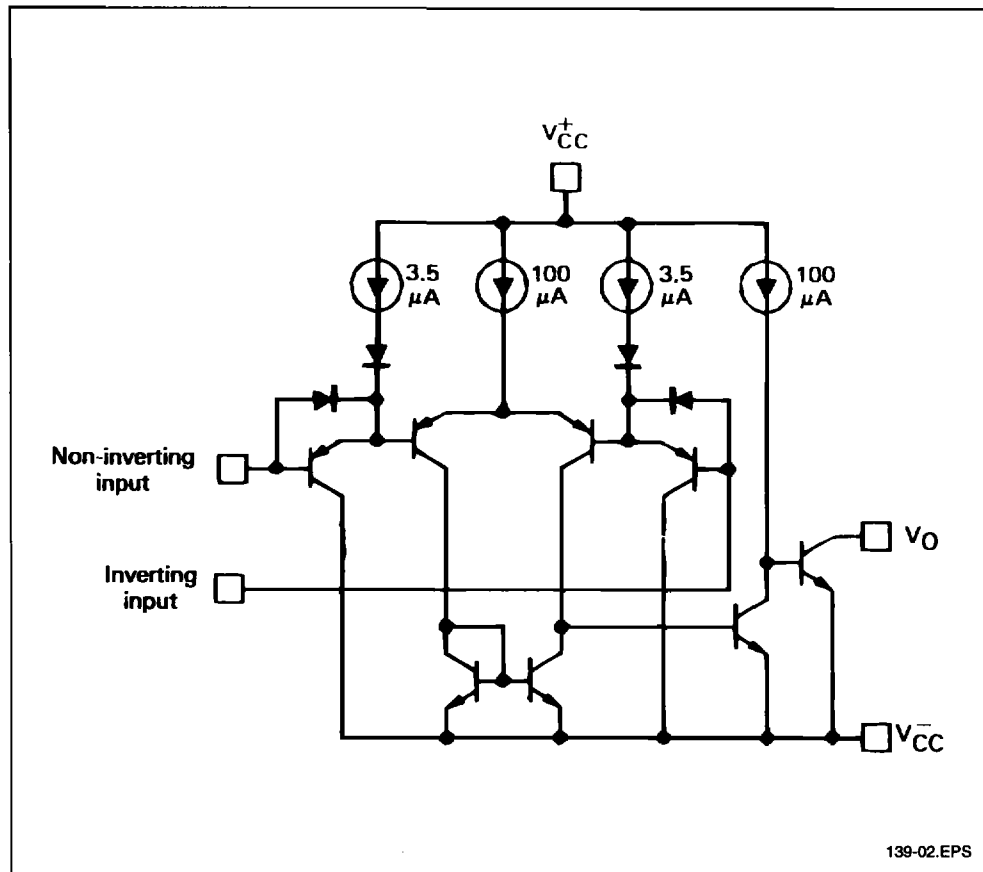

ABSOLUTE MAXIMUM RATINGS

| Symbol | Parameter | LM139,A LM239,A | LM339,A | LM2901 | Unit |
|------------|---|--------------------|----------------|----------------|-------------|
| V_{CC} | Supply Voltage | ± 18 to 36 | ± 18 to 36 | ± 18 to 36 | V |
| V_{id} | Differential Input Voltage | ± 36 | ± 36 | ± 36 | V |
| V_i | Input Voltage | -0.3 to +36 | -0.3 to +36 | -0.3 to +36 | V |
| | Output Short-circuit to Ground - (note 1) | Infinite | | | |
| P_{tot} | Power Dissipation | 570 | 570 | 570 | mW |
| T_{oper} | Operating Free-air Temperature Range | -55, +125 | 0, +70 | -40, +105 | $^{\circ}C$ |
| | LM239,A | -40, +105 | | | |
| T_{stg} | Storage Temperature Range | -65, +150 | -65, +150 | -65, +150 | $^{\circ}C$ |

Notes : 1. Short-circuit from the output to V_{CC}^+ can cause excessive heating and eventual destruction. The maximum output current is approximately 20mA, independent of the magnitude of V_{CC}^+ .

ELECTRICAL CHARACTERISTICS

 $V_{CC}^+ = +5V$, $V_{CC}^- = GND$, $T_{amb} = 25^\circ C$ (unless otherwise specified)

| Symbol | Parameter | LM139A - LM239A LM339A | | | LM139 - LM239 LM339 - LM2901 | | | Unit |
|------------|---|---------------------------|------------|------------------------------------|---------------------------------|------------|------------------------------------|---------------|
| | | Min. | Typ. | Max. | Min. | Typ. | Max. | |
| V_{io} | Input Offset Voltage - (note 2) $T_{amb} = +25^\circ C$ $T_{min.} \leq T_{amb} \leq T_{max.}$ LM2901 LM2901 | | 1 | 2 | | 1 | 5 7 9 15 | mV |
| I_{io} | Input Offset Current $T_{amb} = +25^\circ C$ $T_{min.} \leq T_{amb} \leq T_{max.}$ | | 3 | 25 100 | | 5 | 50 150 | nA |
| I_{ib} | Input Bias Current (I_{i+} or I_{i-}) - (note 3) $T_{amb} = +25^\circ C$ $T_{min.} \leq T_{amb} \leq T_{max.}$ | | 25 | 100 300 | | 25 | 250 400 | nA |
| A_{vd} | Large Signal Voltage Gain ($V_{CC} = 15V$, $R_L = 15k\Omega$, $V_O = 1$ to $11V$) LM2901 | 50 | 200 | | 50 25 | 200 | | V/mV |
| I_{CC} | Supply Current (all comparators) $V_{CC} = +5V$, no load $V_{CC} = +30V$, no load | | 1.1 1.3 | 2 2.5 | | 1.1 1.3 | 2 2.5 | mA |
| V_{ICM} | Input Common Mode Voltage Range - (note 4) ($V_{CC} = 30V$) $T_{amb} = +25^\circ C$ $T_{min.} \leq T_{amb} \leq T_{max.}$ | 0 0 | | $V_{CC}^+ - 1.5$ $V_{CC}^+ - 2$ | 0 0 | | $V_{CC}^+ - 1.5$ $V_{CC}^+ - 2$ | V |
| V_{id} | Differential Input Voltage - (note 6) | | | V_{CC}^+ | | | V_{CC}^+ | V |
| V_{OL} | Low Level Output Voltage ($V_{id} = -1V$, $I_{sink} = 4mA$) $T_{amb} = +25^\circ C$ $T_{min.} \leq T_{amb} \leq T_{max.}$ | | 250 | 400 700 | | 250 | 400 700 | mV |
| I_{OH} | High Level Output Current ($V_{id} = 1V$) ($V_{CC} = V_O = 30V$) $T_{amb} = +25^\circ C$ $T_{min.} \leq T_{amb} \leq T_{max.}$ | | 0.1 | 1 | | 0.1 | 1 | nA μA |
| I_{sink} | Output Sink Current ($V_{id} = -1V$, $V_O = 1.5V$) | 6 | 16 | | 6 | 16 | | mA |
| t_{re} | Response Time - (note 5) ($R_L = 5.1k\Omega$ connected to V_{CC}^+ , $V_{(ref)} = +1.4V$) | | 1.3 | | | 1.3 | | μs |
| t_{rel} | Large Signal Response Time ($R_L = 5.1k\Omega$ connected to V_{CC}^+ , $e_1 = TTL$, $V_{(ref)} = +1.4V$) | | 300 | | | 300 | | ns |

Notes : 2. At output switch point, $V_O = 1.4V$, $R_S = 0$ with V_{CC}^+ from 5V to 30V, and over the full input common-mode range (0V to $V_{CC}^+ - 1.5V$).

3. The direction of the input current is out of the IC due to the PNP input stage. This current is essentially constant, independent of the state of the output, so no loading charge exists on the reference of input lines.

4. The input common-mode voltage of either input signal voltage should not be allowed to go negative by more than 0.3V. The upper end of the common-mode voltage range is $V_{CC}^+ - 1.5V$, but either or both inputs can go to +30V without damage.

5. The response time specified is for a 100mV input step with 5mV overdrive. For larger overdrive signals 300ns can be obtained.

6. Positive excursions of input voltage may exceed the power supply level. As long as the other voltage remains within the common-mode range, the comparator will provide a proper output state. The low input voltage state must not be less than -0.3V (or 0.3V below the negative power supply, if used).

139-03.TBL

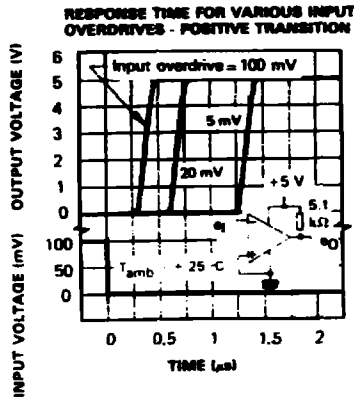
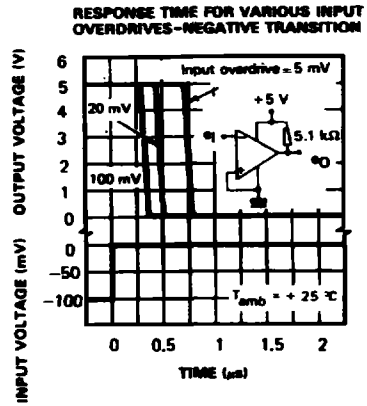
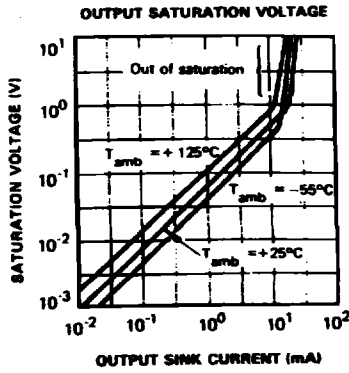
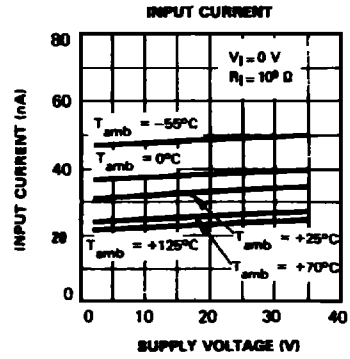
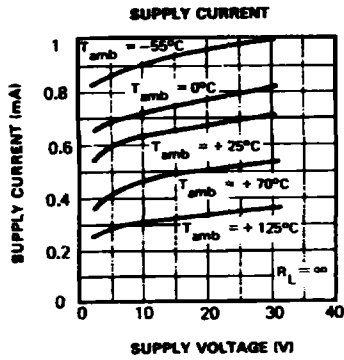

TYPICAL APPLICATIONS

BASIC COMPARATOR

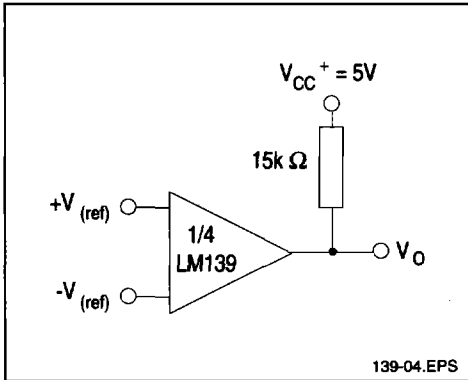

DRIVING CMOS

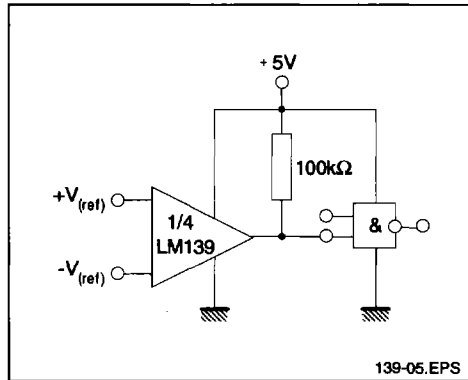

DRIVING TTL

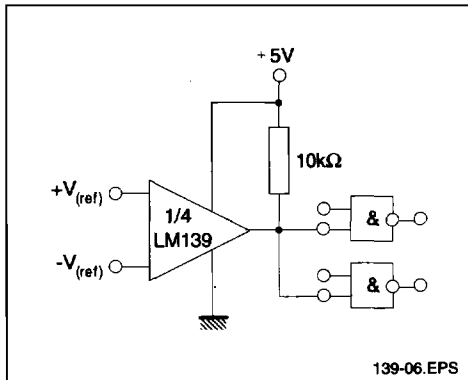

LOW FREQUENCY OP AMP

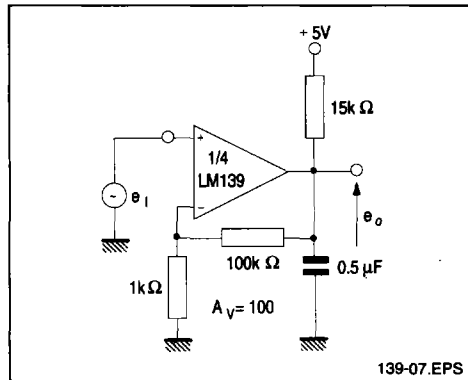

LOW FREQUENCY OP AMP

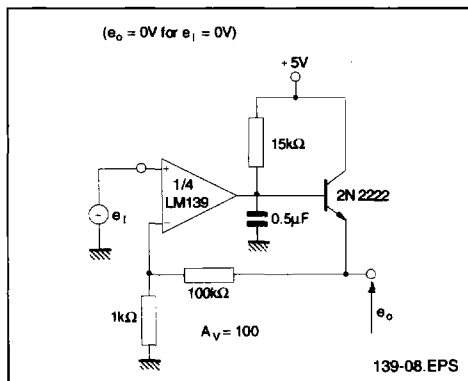

TRANSDUCER AMPLIFIER

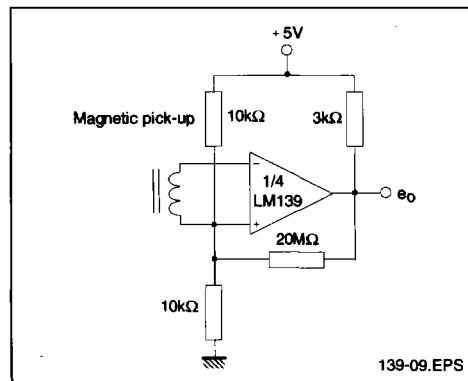

TYPICAL APPLICATIONS (continued)

TIME DELAY GENERATOR

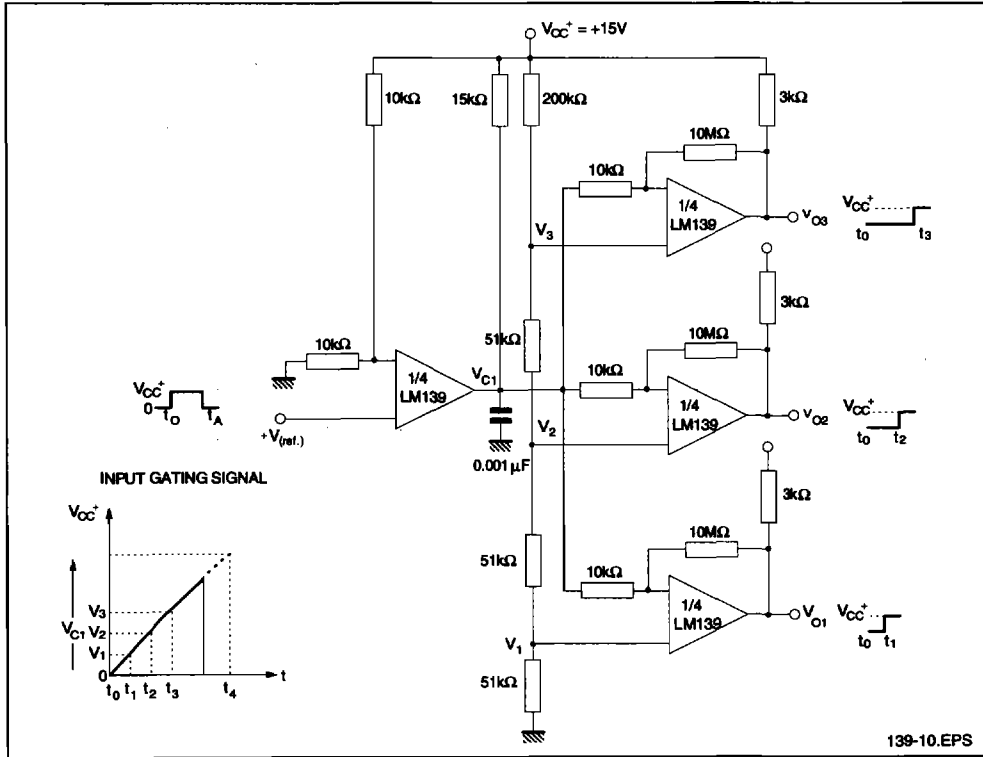

LOW FREQUENCY OP AMP WITH OFFSET ADJUST

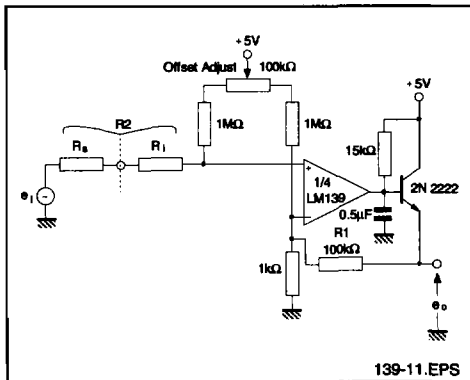

ZERO CROSSING DETECTOR (single power supply)

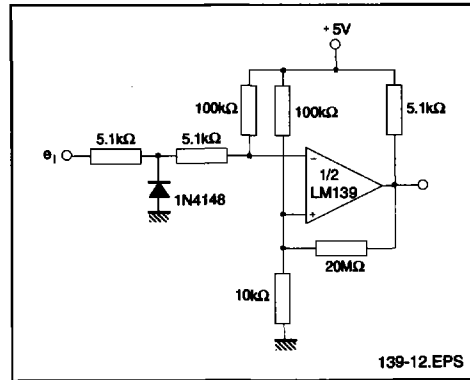

TYPICAL APPLICATIONS (continued)

TWO-DECADE HIGH-FREQUENCY VCO

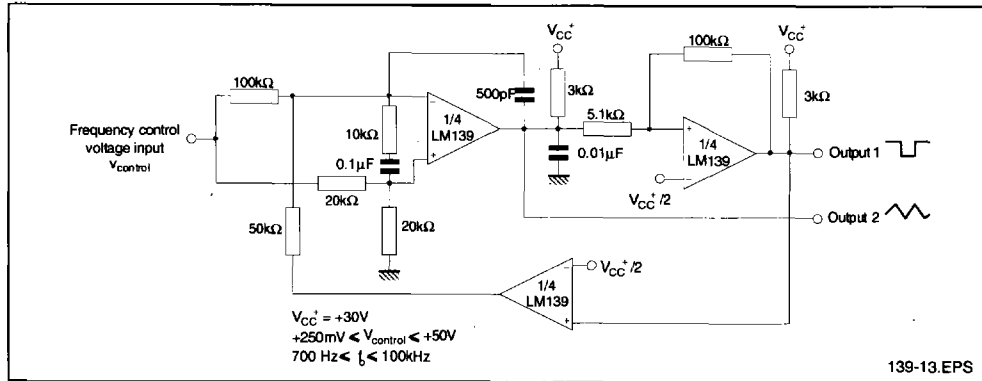

LIMIT COMPARATOR

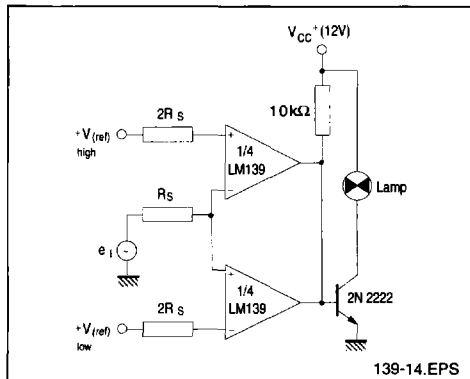

CRYSTAL CONTROLLED OSCILLATOR

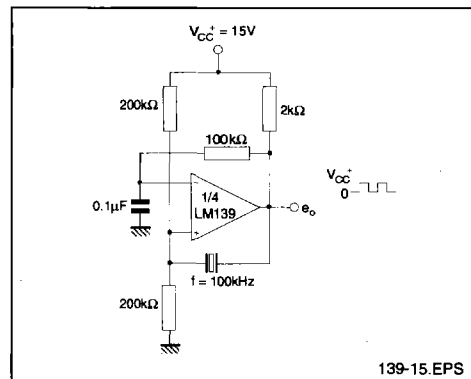

SPLIT-SUPPLY APPLICATIONS

ZERO CROSSING DETECTOR

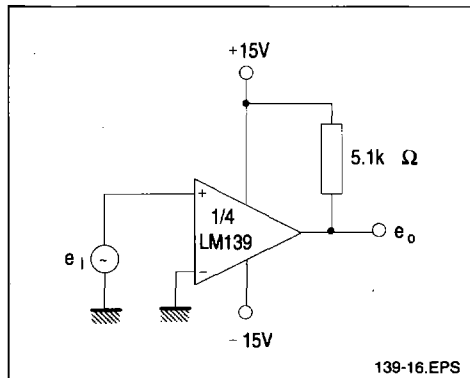

COMPARATOR WITH A NEGATIVE REFERENCE

