

Features

- Three Isolated Zeners in Ultra-Small Surface Mount Package
- Ideally Suited for Automated Assembly Processes

Mechanical Data

- Case: SOT-363, Molded Plastic
- Terminals: Solderable per MIL-STD-202, Method 208
- Orientation: See Diagram
- Marking: Marking Code (See Table on Page 2)
- Weight: 0.006 grams (approx.)

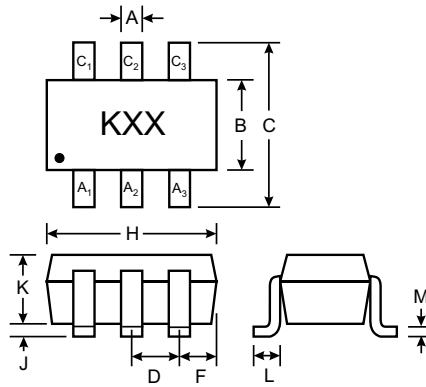

SOT-363		
Dim	Min	Max
A	0.10	0.30
B	1.15	1.35
C	2.00	2.20
D	0.65 Nominal	
F	0.30	0.40
H	1.80	2.20
J	—	0.10
K	0.90	1.00
L	0.25	0.40
M	0.10	0.25
All Dimensions in mm		

Maximum Ratings @ T_A = 25°C unless otherwise specified

Characteristic	Symbol	Value	Unit
Forward Voltage @ I _F = 10mA	V _F	0.9	V
Power Dissipation (Note 1)	P _d	200	mW
Thermal Resistance, Junction to Ambient Air (Note 1)	R _{θJA}	625	K/W
Operating and Storage Temperature Range	T _J , T _{STG}	-65 to +150	°C

- Notes:
1. Valid provided that device terminals are kept at ambient temperature.
 2. Tested with pulses, T_p ≤ 1.0ms.

Electrical Characteristics @ $T_A = 25^\circ\text{C}$ unless otherwise specified

Type Number	Marking Code	Zener Voltage Range (Note 2)				Maximum Zener Impedance		Maximum Reverse Leakage Current	
		$V_Z @ I_{ZT}$			I_{ZT}	$Z_{ZT} @ I_{ZT}$	$Z_{ZK} @ I_{ZK} = 0.25\text{mA}$	I_R	@ V_R
		Nom (V)	Min (V)	Max (V)	mA	Ω		μA	V
MMBZ5221BTS	KSB	2.4	2.28	2.52	20	30	1200	100	1.0
MMBZ5223BTS	KSC	2.7	2.57	2.84	20	30	1300	75	1.0
MMBZ5225BTS	KSD	3.0	2.85	3.15	20	30	1600	50	1.0
MMBZ5226BTS	KSE	3.3	3.14	3.47	20	28	1600	25	1.0
MMBZ5227BTS	KSF	3.6	3.42	3.78	20	24	1700	15	1.0
MMBZ5228BTS	KSG	3.9	3.71	4.10	20	23	1900	10	1.0
MMBZ5229BTS	KSH	4.3	4.09	4.52	20	22	2000	5.0	1.0
MMBZ5230BTS	KS1	4.7	4.47	4.94	20	19	1900	5.0	2.0
MMBZ5231BTS	KS2	5.1	4.85	5.36	20	17	1600	5.0	2.0
MMBZ5232BTS	KS3	5.6	5.32	5.88	20	11	1600	5.0	3.0
MMBZ5233BTS	KRF	6.0	5.70	6.30	20	7	1600	5.0	3.5
MMBZ5234BTS	KS4	6.2	5.89	6.51	20	7	1000	5.0	4.0
MMBZ5235BTS	KS5	6.8	6.46	7.14	20	5	750	3.0	5.0
MMBZ5236BTS	KS6	7.5	7.13	7.88	20	6	500	3.0	6.0
MMBZ5237BTS	KS7	8.2	7.79	8.61	20	8	500	3.0	6.5
MMBZ5238BTS	KRG	8.7	8.27	9.14	20	8	600	3.0	6.5
MMBZ5239BTS	KS8	9.1	8.65	9.56	20	10	600	3.0	7.0
MMBZ5240BTS	KS9	10	9.50	10.50	20	17	600	3.0	8.0
MMBZ5241BTS	KR1	11	10.45	11.55	20	22	600	2.0	8.4
MMBZ5242BTS	KR2	12	11.40	12.60	20	30	600	1.0	9.1
MMBZ5243BTS	KR3	13	12.35	13.65	9.5	13	600	0.5	9.9
MMBZ5245BTS	KR4	15	14.25	15.75	8.5	16	600	0.1	11
MMBZ5246BTS	KR5	16	15.20	16.80	7.8	17	600	0.1	12
MMBZ5248BTS	KR6	18	17.10	18.90	7.0	21	600	0.1	14
MMBZ5250BTS	KR7	20	19.00	21.00	6.2	25	600	0.1	15
MMBZ5251BTS	KR8	22	20.90	23.10	5.6	29	600	0.1	17
MMBZ5252BTS	KR9	24	22.80	25.20	5.2	33	600	0.1	18
MMBZ5254BTS	KRA	27	25.65	28.35	5.0	41	600	0.1	21
MMBZ5255BTS	KRH	28	26.60	29.40	4.5	44	600	0.1	21
MMBZ5256BTS	KRB	30	28.50	31.50	4.2	49	600	0.1	23
MMBZ5257BTS	KRC	33	31.35	34.65	3.8	58	700	0.1	25
MMBZ5258BTS	KRD	36	34.20	37.80	3.4	70	700	0.1	27
MMBZ5259BTS	KRE	39	37.05	40.95	3.2	80	800	0.1	30

- Notes: 1. Valid provided that device terminals are kept at ambient temperature.
2. Tested with pulses, $T_p \leq 1.0\text{ms}$.

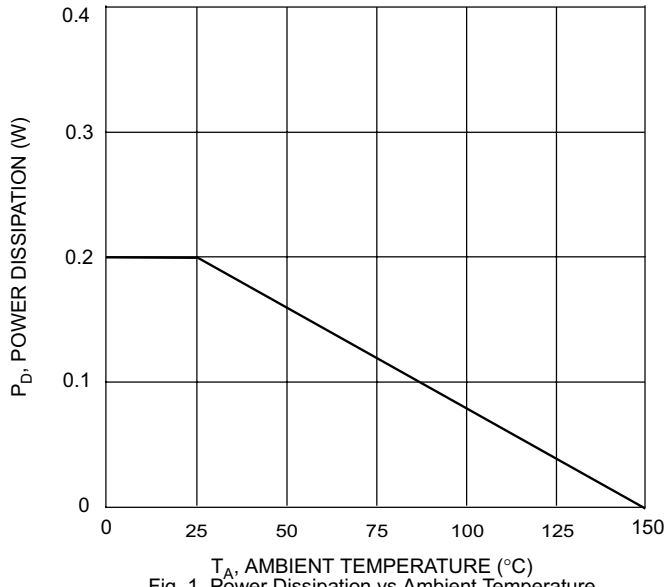

Fig. 1 Power Dissipation vs Ambient Temperature