

SCHOTTKY DIODES MODULE TYPE 400A

Features

High Surge Capability
Types Up to 100V V_{RRM}

400Amp Rectifier
20-100 Volts

FULL PACKAGE

Maximum Ratings

Operating Temperature: -40°C to $+175^{\circ}\text{C}$
Storage Temperature: -40°C to $+175^{\circ}\text{C}$

Part Number	Maximum Recurrent Peak Reverse Voltage	Maximum RMS Voltage	Maximum DC Blocking Voltage
MBRF40020(R)	20V	14V	20V
MBRF40030(R)	30V	21V	30V
MBRF40035(R)	35V	25V	35V
MBRF40040(R)	40V	28V	40V
MBRF40045(R)	45V	32V	45V
MBRF40060(R)	60V	42V	60V
MBRF40080(R)	80V	56V	80V
MBRF400100(R)	100V	70V	100V

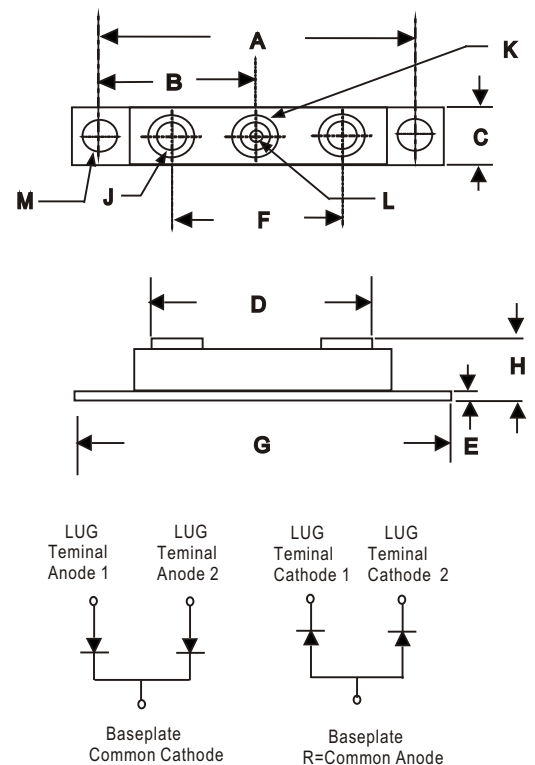

Electrical Characteristics @ 25 °C Unless Otherwise Specified

Average Forward Current (Per pkg)	$I_{F(AV)}$	400A	$T_C = 125^{\circ}\text{C}$
Peak Forward Surge Current (Per leg)	I_{FSM}	3000A	8.3ms, half sine
Maximum Instantaneous Forward Voltage (Per leg) NOTE (1)	V_F	0.65V 0.75V 0.84V	(MBRF40020-MBRF40045) (MBRF40060) (MBRF40080-MBRF400100) $I_{FM} = 200A; T_j = 25^{\circ}\text{C}$
Maximum Instantaneous Reverse Current At Rated DC Blocking Voltage (Per leg) NOTE (1)	I_R	5.0 mA 200 mA	$T_j = 25^{\circ}\text{C}$ $T_j = 125^{\circ}\text{C}$
Maximum Thermal Resistance Junction To Case (Per leg)	$R_{\theta jc}$	0.8°C/W	

NOTE :

(1) Pulse Test: Pulse Width 300 usec, Duty Cycle < 2%

DIM	DIMENSIONS				NOTE
	INCHES		MM		
	MIN	MAX	MIN	MAX	
A	3.150	NOM	80.01	NOM	
B	1.565	1.585	39.75	40.26	
C	.700	.800	17.78	20.32	
E	.119	.132	3.02	3.35	
F	1.375	REF	34.92	REF	
G	3.55	3.65	90.17	92.71	
H	.604	.635	15.35	16.35	
J	1/4	- 20	UNC	FULL	
K	.380	.410	9.65	10.41	∅
L	.185	.195	4.70	4.95	∅
M	.275	.295	6.99	7.49	∅

MBRF40020(R) THRU MBRF400100(R)

Figure .1-Typical Forward Characteristics

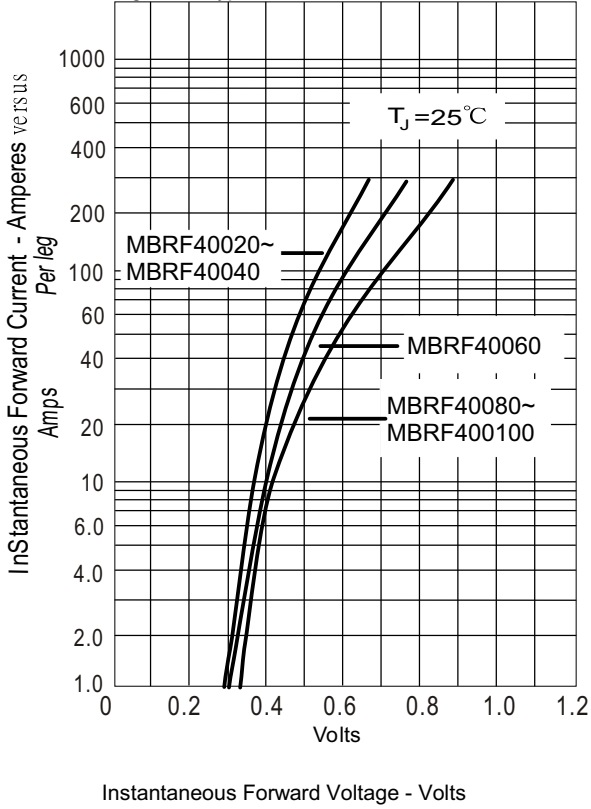

Figure .2- Forward Derating Curve

