

**SWITCHING REGULATOR CONTROL CIRCUIT  
SILICON MONOLITHIC BIPOLAR INTEGRATED CIRCUIT**

**DESCRIPTION**

The  $\mu$ PC494 is an inverter control unit which provides all the control circuitry for PWM type switching regulators. Included in this device is the voltage reference, dual error amplifiers, oscillator, pulse width modulator, pulse steering flip flop, dual alternating output switches and dead time control.

**FEATURES**

- Complete PWM Power Control Circuit.
- Adjustable Dead-time (0 to 100 %).
- No Double pulsing of same output during load transient condition.
- Dual error amplifiers have wide common mode input voltage capability ( $-0.3$  V to  $V_{CC}-2$  V).
- Circuit architecture provides easy synchronization.
- Uncommitted outputs for 250 mA sink or source.
- With Miss-operation Prevention Circuit for low level supply voltage.
- Full Pin-Compatible TL494C.

**ORDERING INFORMATION**

Part Number	Package
$\mu$ PC494C	16 Pin Plastic DIP (300 mil)
$\mu$ PC494G	16 Pin Plastic SOP (375 mil)
$\mu$ PC494GS	16 Pin Plastic SOP (300 mil)

**CONNECTION DIAGRAM (Top View)**

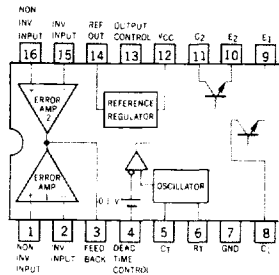

BLOCK DIAGRAM

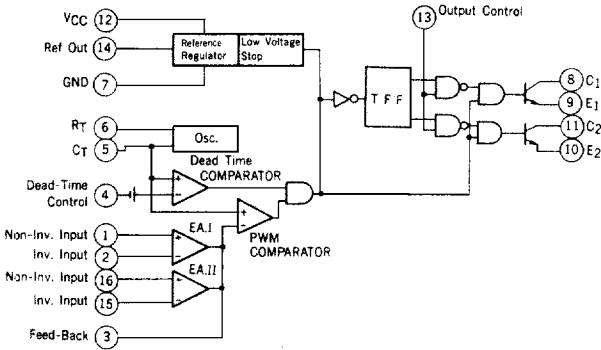

ABSOLUTE MAXIMUM RATINGS (T<sub>a</sub>=25 °C)

Supply Voltage	V <sub>CC</sub>	41	V
Error Amplifier Input Voltage	V <sub>ICM</sub>	V <sub>CC</sub> +0.3	V
Output Voltage	V <sub>CER</sub>	41	V
Output Current	I <sub>C</sub>	250	mA
Total Power Dissipation	P <sub>T</sub> (T <sub>a</sub> =25 °C)	1000	mW
Operating Temperature Range	T <sub>opt</sub>	-20 to +85	°C
Storage Temperature Range	T <sub>stg</sub>	-65 to +150	°C

RECOMMENDED OPERATING CONDITIONS

CHARACTERISTIC	SYMBOL	MIN.	TYP.	MAX.	UNIT
Supply Voltage	V <sub>CC</sub>	7		40	V
Output Voltage	V <sub>CER</sub>	-0.3		40	V
Output Current	I <sub>C</sub>			200	mA
Error Amplifier Sink Current	I <sub>OAMP</sub>			-0.3	mA
Timing capacitor	C <sub>T</sub>	0.47		10 000	nF
Timing Resistance	R <sub>T</sub>	1.8		500	kΩ
Oscillation Frequency	f <sub>osc</sub>	1		300	kHz
Operating Temperature	T <sub>opt</sub>	-20		+70	°C

**ELECTRICAL CHARACTERISTICS** ( $V_{CC}=15\text{ V}$ ,  $f=10\text{ kHz}$ ,  $-20 \leq T_a \leq +70\text{ }^\circ\text{C}$ , unless otherwise noted)

BLOCK	CHARACTERISTIC	SYMBOL	MIN.	TYP.	MAX.	UNIT	TEST CONDITIONS	
Reference Section	Output Voltage	$V_{ref}$	4.75	5	5.25	V	$I_{ref}=1\text{ mA}$ , $T_a=25\text{ }^\circ\text{C}$	
	Line Regulation	$REG_{IN}$		8	25	mV	$7\text{ V} \leq V_{CC} \leq 40\text{ V}$ $I_{ref}=1\text{ mA}$ , $T_a=25\text{ }^\circ\text{C}$	
	Load Regulation	$REG_L$		1	15	mV	$1\text{ mA} \leq I_{ref} \leq 10\text{ mA}$ , $T_a=25\text{ }^\circ\text{C}$	
	Temperature Coefficient	$V_{ref}$		0.01	0.03	%/ $^\circ\text{C}$	$-20\text{ }^\circ\text{C} = T_a \leq +85\text{ }^\circ\text{C}$ $I_{ref}=1\text{ mA}$	
	(Note 2) Short Circuit Output Current	$I_{short}$		50		mA	$V_{ref}=0$ , $T_a=25\text{ }^\circ\text{C}$	
Oscillator Section	Frequency	$f_{osc}$		10		kHz	$C_T=0.01\text{ }\mu\text{F}$ , $R_T=12\text{ k}\Omega$ , $T_a=25\text{ }^\circ\text{C}$	
	(Note 1) Standard Deviation of Frequency			10		%	$7\text{ V} \leq V_{CC} \leq 40\text{ V}$ , $C_T$ , $R_T$ , const. $T_a=25\text{ }^\circ\text{C}$	
	Frequency Change with Temperature			1	2	%	$0\text{ }^\circ\text{C} \leq T_a \leq 70\text{ }^\circ\text{C}$ , $C_T=0.01\text{ }\mu\text{F}$ $R_T=12\text{ k}\Omega$	
	Frequency Change with Voltage				1	%	$7\text{ V} \leq V_{CC} \leq 40\text{ V}$ , $C_T=0.01\text{ }\mu\text{F}$ $T_a=25\text{ }^\circ\text{C}$ , $R_T=12\text{ k}\Omega$	
Dead-time Control Section	Input Bias Current			-2	-10	$\mu\text{A}$	$0 \leq V_I \leq 5.25\text{ V}$	
	Maximum Duty Cycle (Each Output)		45	49		%	$V_I=0$	
	Input Threshold Voltage	$V_{th}$	0	3	3.3	V	Zero duty cycle Maximum duty cycle	
Error Amplifier Section	Input Offset Voltage	$V_{IO}$		2	10	mV	$VOAMP=2.5\text{ V}$	
	Input Offset Current	$I_{IO}$		25	250	nA	$VOAMP=2.5\text{ V}$	
	Input Bias Current			0.2	1	$\mu\text{A}$	$VOAMP=2.5\text{ V}$	
	Common Mode Input Voltage	Low	$V_{ICM}$	-0.3			V	$7\text{ V} \leq V_{CC} \leq 40\text{ V}$
		High		$V_{CC}-2$				
	Open-loop Voltage Amplification	$A_v$	60	80		dB	$VOAMP=0.5\text{ V to }3.5\text{ V}$ , $T_a=25\text{ }^\circ\text{C}$	
	Unity Gain Bandwidth		500	830		kHz	$T_a=25\text{ }^\circ\text{C}$	
	Common Mode Rejection Ratio	CMR	65	80		dB	$V_{CC}=40\text{ V}$ , $T_a=25\text{ }^\circ\text{C}$	
	Output Sink Current		0.3	0.7		mA	$VOAMP=0.7\text{ V}$	
Output Source Current		-2	-10		mA	$VOAMP=3.5\text{ V}$		

Note 1: Standard deviation is a measure of the statistical distribution about the mean as derived from the formula;

Calculation expression of frequency  $f_{osc}$  is as follows

$$f_{osc} \approx \frac{1}{0.817 R_T C_T + 1.42 \cdot 10^{-6}} \text{ (Hz)} \quad [R_T] = \Omega, [C_T] = F$$

$$\sigma = \sqrt{\frac{\sum_{n=1}^N (X_n - \bar{X})^2}{N - 1}}$$

Note 2: Maximum duration of short circuit cond. is one second. (non repetitive)

BLOCK	CHARACTERISTIC		SYMBOL	MIN.	TYP.	MAX.	UNIT	TEST CONDITIONS	
PWM Section	Input Threshold Voltage				4	4.5	V	Zero Duty Cycle	
	Input Sink Current			0.3	0.7		mA	V <sub>(pin 3)</sub> =0.7 V	
Output Section	Collector Cutoff Current		I <sub>CER</sub>			100	μA	V <sub>CE</sub> =40 V, V <sub>CC</sub> =40 V	
	Emitter Cutoff Current					-100	μA	V <sub>CC</sub> =V <sub>C</sub> =40 V	
	Collector Saturation Voltage		V <sub>CE(sat)</sub>		0.95	1.3	V	I <sub>C</sub> =200 mA, V <sub>E</sub> =0, Common Emitter	
			V <sub>CE(ON)</sub>		1.6	2.5	V	I <sub>E</sub> =200 mA, V <sub>C</sub> =15 V Emitter follower	
	Output Voltage Rise Time	common Emitter	t <sub>r</sub>		100	200	ns	V <sub>CC</sub> =15 V, R <sub>L</sub> =150 Ω I <sub>Q</sub> =100 mA T <sub>a</sub> =25 °C	
		Emitter follower			100	200	ns		
Output Voltage Fall Time	common Emitter	t <sub>f</sub>		70	200	ns			
	Emitter follower			70	200	ns			
Total Device	Standby Current		I <sub>CC(S.B)</sub>		8	12.5	mA		V <sub>CC</sub> =15 V all other inputs and outputs open
	Bias Current		I <sub>CC(BI.)</sub>		10		mA		V <sub>(pin 4)</sub> =2 V, see Fig. 1

Fig. 1 Test Circuit

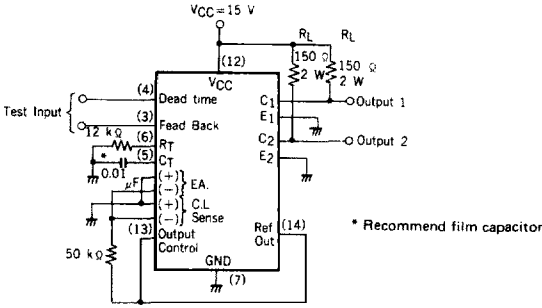

Voltage Waveform

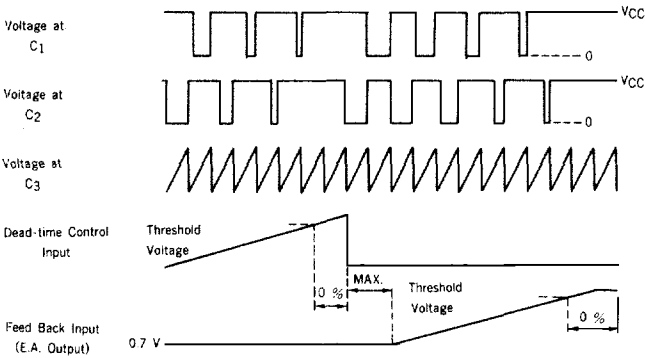

FUNCTION TABLE

OUTPUT CONTROL INPUT (13 pin)	OUTPUT FUNCTION
At Ref-Out	Normal push-pull operation
Grounded	Single-ended or parallel output

TYPICAL PERFORMANCE CHARACTERISTICS ( $T_a=25 \pm 2^\circ\text{C}$ ,  $V_{IN}=15\text{ V}$ )

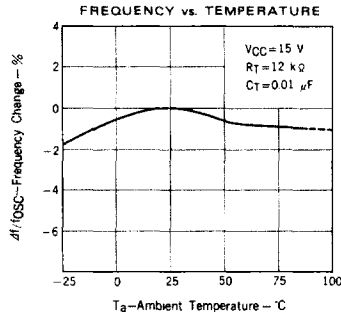
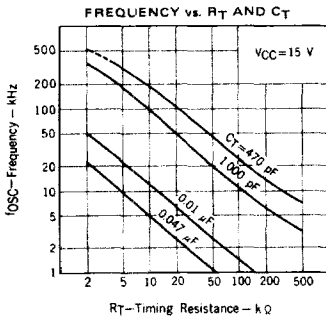
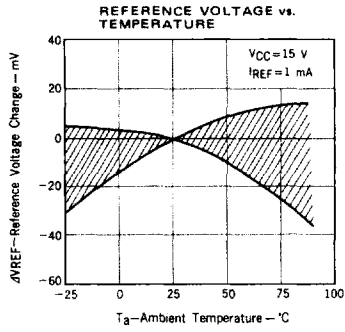
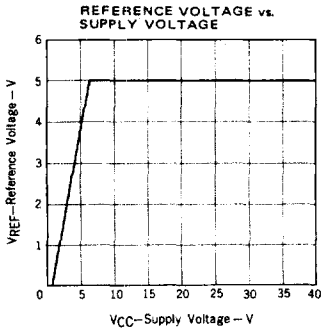
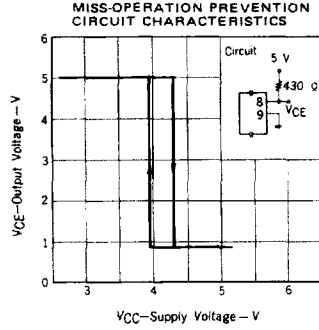
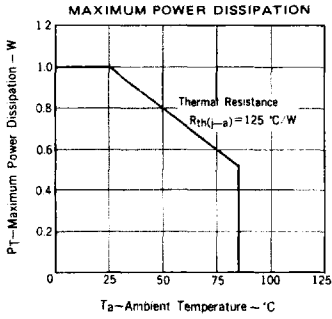

DUTY CYCLE vs. DEAD TIME CONTROL INPUT VOLTAGE

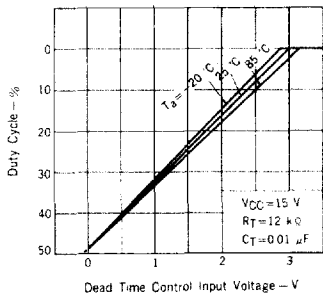

OPEN-LOOP VOLTAGE GAIN vs. FREQUENCY

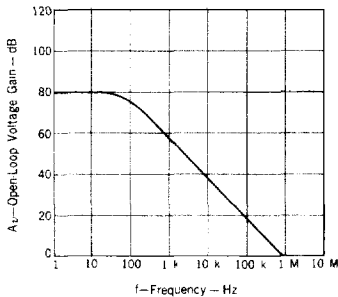

COLLECTOR SATURATION VOLTAGE vs. OUTPUT CURRENT

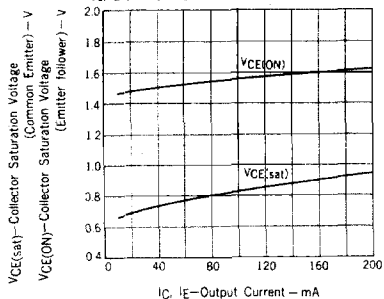

STANDBY AND BIAS CURRENT vs. SUPPLY VOLTAGE

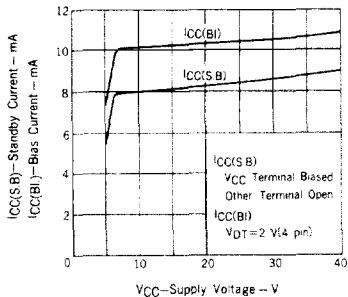

BASIC APPLICATION CIRCUIT

Fig. 2 Circuit

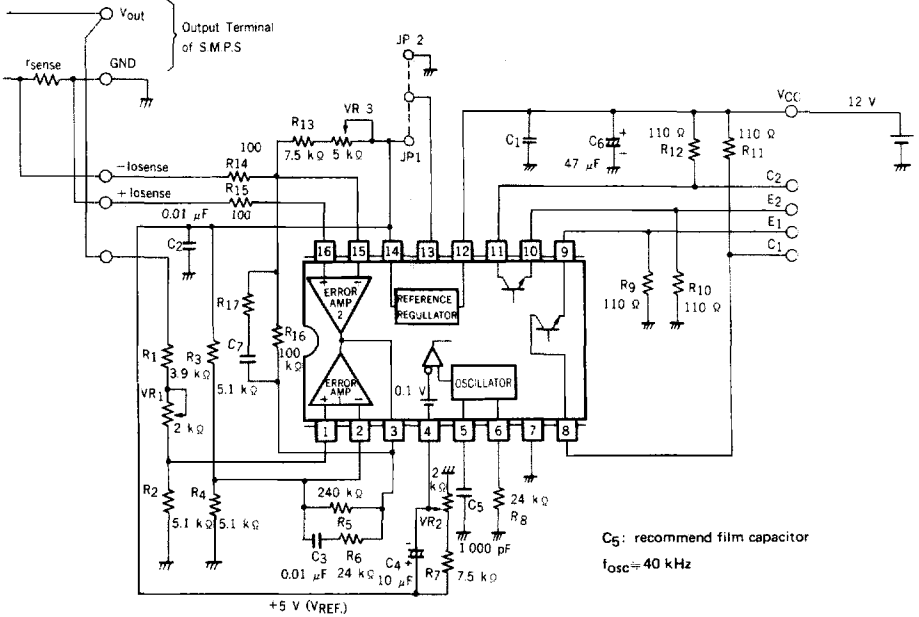

CONNECTION DIAGRAM

OUTPUT FUNCTION	OUTPUT CONTROL INPUT (13 pin)	OUTPUT MODE	OUTPUT VOLTAGE WAVEFORM
Push-Pull Operation	At Ref-Out (JP1 Wired)	Open Collector (R <sub>9</sub> , R <sub>10</sub> 0 Ω)	C1
		Emitter Follower (R <sub>11</sub> , R <sub>12</sub> 0 Ω)	C2
Single-Ended or Parallel Output	Grounded (JP2 Wired)	Open Collector (R <sub>9</sub> , R <sub>10</sub> 0 Ω)	E1
		Emitter Follower (R <sub>11</sub> , R <sub>12</sub> 0 Ω)	E2



Printed Pattern (Pattern Side, Actual Size)

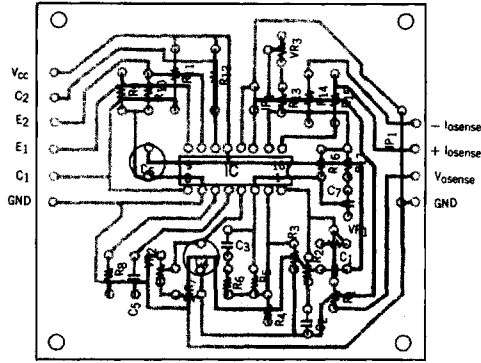

TYPICAL EXAMPLE OF APPLICATION CIRCUITS

1) Forward Type

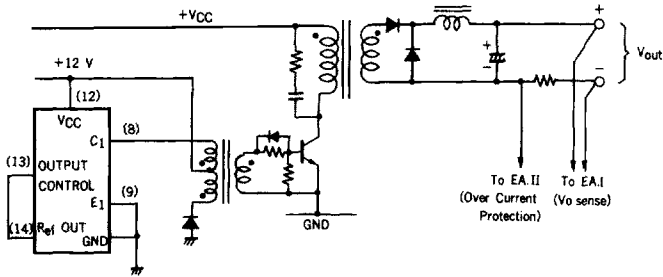

2) Push-pull Type

(Isolated)

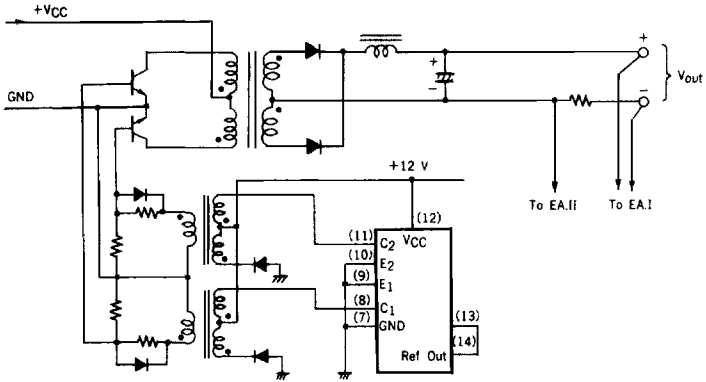

(Non Isolated)

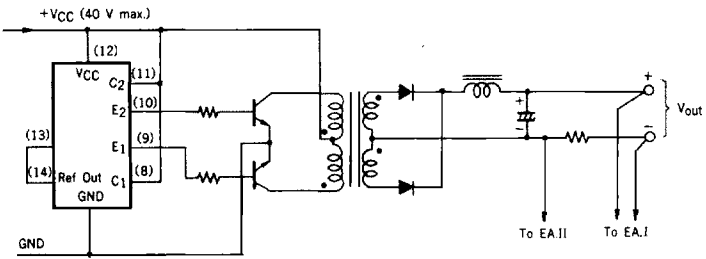

3) Stepdown Chopper

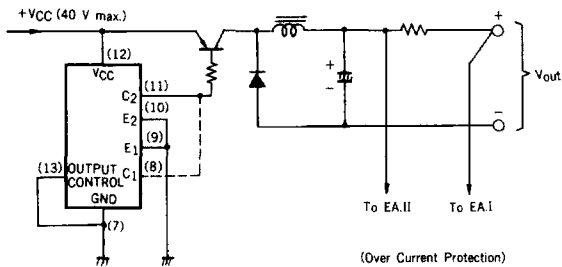

**SYNCHRONIZED OPERATION**

If synchronized operation is needed, master-slave circuit can be used. This circuit is shown below. Initially,  $R_T$  terminal of slave IC is connected to Pin 14 (Ref Out) and internal oscillator is stopped.

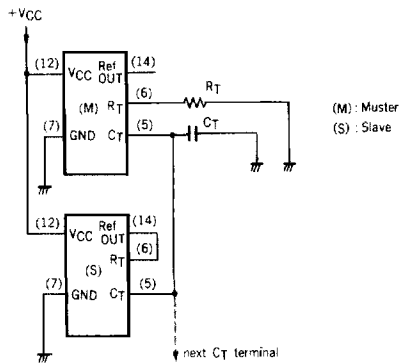

16 PIN PLASTIC DIP (300 mil) (μPC494C)

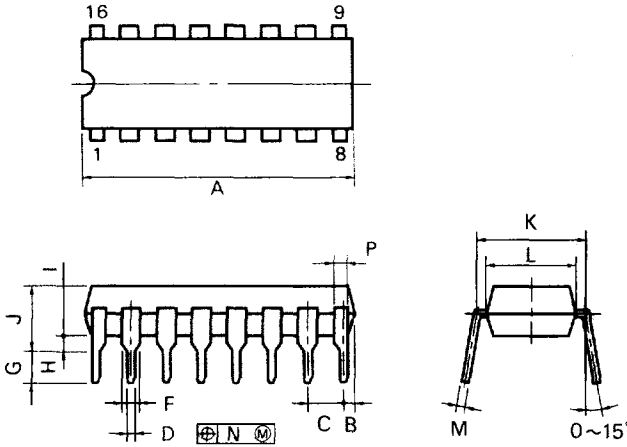

P16C-100-300B

NOTES

- 1) Each lead centerline is located within 0.25 mm (0.01 inch) of its true position (T.P.) at maximum material condition.
- 2) Item "K" to center of leads when formed parallel.

ITEM	MILLIMETERS	INCHES
A	20.32 MAX.	0.800 MAX.
B	1.27 MAX.	0.050 MAX.
C	2.54 (T.P.)	0.100 (T.P.)
D	0.50 <sup>+0.10</sup>	0.020 <sup>+0.004</sup>
F	1.1 MIN.	0.043 MIN.
G	3.5 <sup>+0.3</sup>	0.138 <sup>+0.012</sup>
H	0.51 MIN.	0.020 MIN.
I	4.31 MAX.	0.170 MAX.
J	5.08 MAX.	0.200 MAX.
K	7.62 (T.P.)	0.300 (T.P.)
L	6.5	0.256
M	0.25 <sup>+0.10</sup>	0.010 <sup>+0.004</sup>
N	0.25	0.01
P	1.1 MIN.	0.043 MIN.

16PIN PLASTIC SOP (375 mil) (μPC494G)

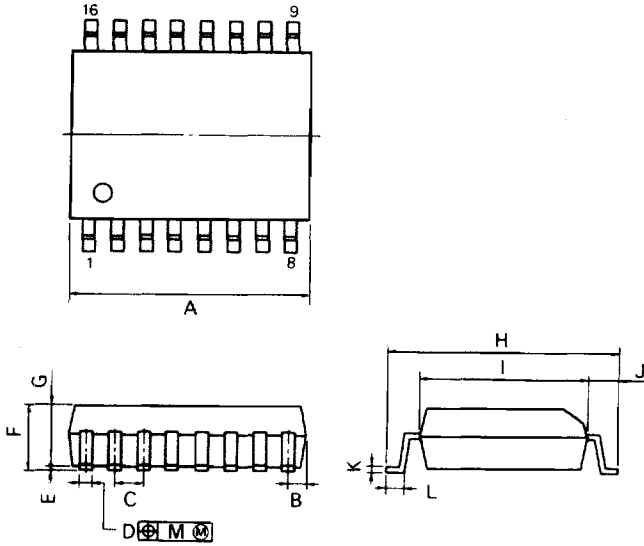

NOTE

Each lead centerline is located within 0.12 mm (0.005 inch) of its true position (T.P.) at maximum material condition.

P16GM-50-375B-1

ITEM	MILLIMETERS	INCHES
A	10.46 MAX.	0.412 MAX.
B	0.78 MAX.	0.031 MAX.
C	1.27 (T.P.)	0.050 (T.P.)
D	0.40 <sup>+0.10</sup> / <sub>-0.08</sub>	0.016 <sup>-0.004</sup> / <sub>-0.003</sub>
E	0.1 <sup>+0.2</sup> / <sub>-0.1</sub>	0.004 <sup>-0.008</sup> / <sub>-0.004</sub>
F	2.9 MAX.	0.115 MAX.
G	2.50	0.098
H	10.3 <sup>+0.3</sup> / <sub>-0.3</sub>	0.406 <sup>-0.013</sup> / <sub>-0.013</sub>
I	7.2	0.283
J	1.6	0.063
K	0.15 <sup>+0.10</sup> / <sub>-0.08</sub>	0.006 <sup>-0.004</sup> / <sub>-0.002</sub>
L	0.8 <sup>+0.2</sup> / <sub>-0.2</sub>	0.031 <sup>-0.008</sup> / <sub>-0.008</sub>
M	0.12	0.005

16PIN PLASTIC SOP (300 mil) (μPC494GS)

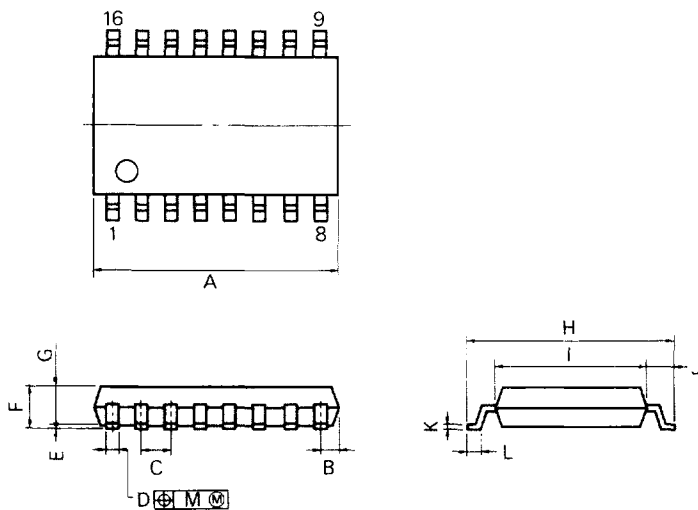

P16GM-50-300B-1

NOTE

Each lead centerline is located within 0.12 mm (0.005 inch) of its true position (T.P.) at maximum material condition.

ITEM	MILLIMETERS	INCHES
A	10.46 MAX.	0.412 MAX.
B	0.78 MAX.	0.031 MAX.
C	1.27 (T.P.)	0.050 (T.P.)
D	0.40 <sup>+0.10</sup> <sub>-0.08</sub>	0.016 <sup>0.004</sup> <sub>0.003</sub>
E	0.1 <sup>-0.1</sup>	0.004 <sup>0.004</sup>
F	1.8 MAX.	0.071 MAX.
G	1.55	0.061
H	7.7 <sup>-0.3</sup>	0.303 <sup>-0.012</sup>
I	5.6	0.220
J	1.1	0.043
K	0.20 <sup>0.10</sup> <sub>0.08</sub>	0.008 <sup>0.004</sup> <sub>0.003</sub>
L	0.6 <sup>-0.2</sup>	0.024 <sup>0.008</sup> <sub>0.004</sub>
M	0.12	0.005