



3V MICROPOWER QUAD CMOS VOLTAGE COMPARATORS

- DEDICATED TO **3.3V** OR **BATTERY SUPPLY** (specified at 3V and 5V)
- PUSH-PULL CMOS OUTPUT (NO EXTERNAL PULL-UP RESISTOR REQUIRED)
- EXTREMELY LOW SUPPLY CURRENT : **7 μ A typ / comparator**
- WIDE SINGLE SUPPLY RANGE **2.7V to 16V**
- EXTREMELY LOW INPUT OFFSET CURRENTS : **1pA typ**
- INPUT COMMON-MODE VOLTAGE RANGE INCLUDES GND
- FAST RESPONSE TIME : 2 μ s typ for 5mV overdrive
- PIN-TO-PIN AND FUNCTIONALLY COMPATIBLE WITH BIPOLAR LM339

DESCRIPTION

The TS3V3704 is a micropower quad CMOS voltage comparator with extremely low consumption of 7 μ A typ / comparator (20 times less than bipolar LM339). The push-pull CMOS output stage allows power and space saving by eliminating the external pull-up resistor required by usual open-collector output comparators.

Thus response times remain similar to the LM339.

ORDER CODE

Part Number	Temperature Range	Package		
		N	D	P
TS3V3704I	-40°C, +125°C	•	•	•

N = Dual in Line Package (DIP)
D = Small Outline Package (SO) - also available in Tape & Reel (DT)
P = Thin Shrink Small Outline Package (TSSOP) - only available in Tape & Reel (PT)

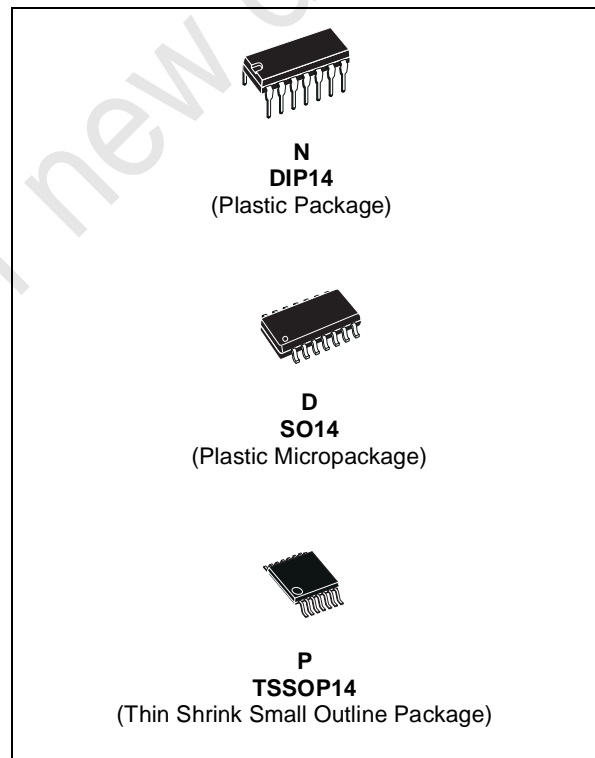

PIN CONNECTIONS (top view)

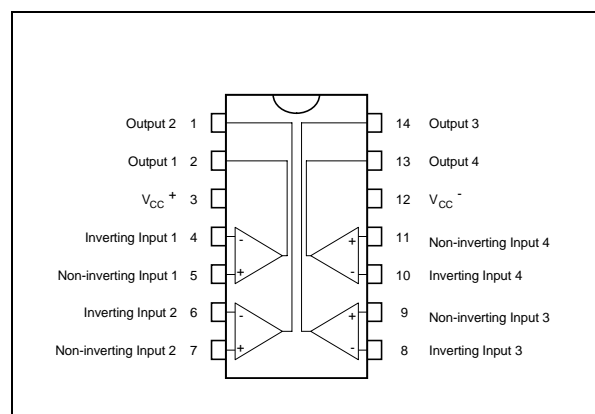

TS3V3704

SCHEMATIC DIAGRAM (for 1/4 TS3V3704)

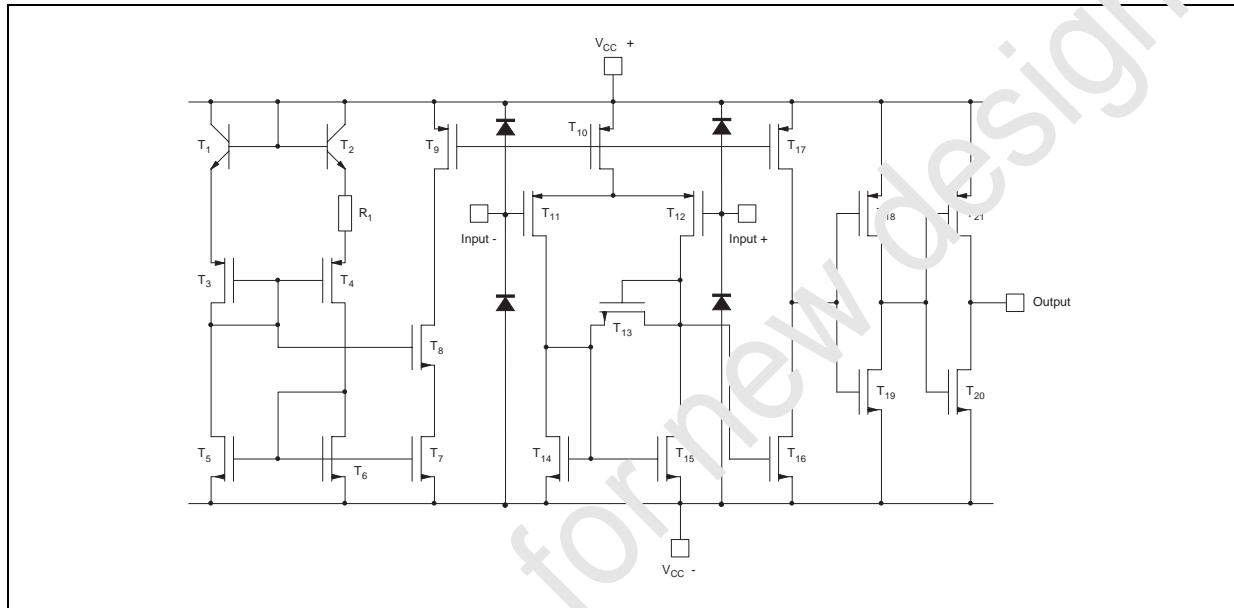

ABSOLUTE MAXIMUM RATINGS

Symbol	Parameter	Value	Unit
V_{CC}^+	Supply Voltage ¹⁾	18	V
V_{id}	Differential Input Voltage ²⁾	± 18	V
V_i	Input Voltage ³⁾	18	V
V_o	Output Voltage	18	V
I_o	Output Current	20	mA
I_F	Forward Current in ESD Protection Diodes on Input ⁴⁾	50	mA
P_d	Power Dissipation ⁵⁾	DIP14 SO14 TSSOP14	1500 830 710
T_{stg}	Storage Temperature Range	-65 to +150	°C

1. All voltage values, except differential voltage, are with respect to network ground terminal.
2. Differential voltages are the non-inverting input terminal with respect to the inverting input terminal.
3. The magnitude of the input and the output voltages must never exceed the magnitude of the positive supply voltage.
4. Guaranteed by design.
5. P_d is calculated with $T_{amb} = +25^\circ\text{C}$, $T_j = +150^\circ\text{C}$ and $R_{thja} = 80^\circ\text{C/W}$ for DIP14 package
 $= 150^\circ\text{C/W}$ for SO14 package
 $= 175^\circ\text{C/W}$ for TSSOP14 package

OPERATING CONDITIONS

Symbol	Parameter	Value	Unit
V_{CC}^+	Supply Voltage	2.7 to 16	V
V_{icm}	Common Mode Input Voltage Range	0 to $V_{CC}^+ - 1.5$	V
T_{oper}	Operating Free-Air Temperature range TS3V3704I	-40 to +125	°C

ELECTRICAL CHARACTERISTICS
 $V_{CC}^+ = 3V$, $V_{CC}^- = 0V$, $T_{amb} = 25^\circ C$ (unless otherwise specified)

Symbol	Parameter	Min.	Typ.	Max.	Unit
V_{io}	Input Offset Voltage $V_{ic} = 1.5V$ - note 1) $T_{min.} \leq T_{amb} \leq T_{max.}$			5 6.5	mV
I_{io}	Input Offset Voltage - note 2) $V_{ic} = 1.5V$ $T_{min.} \leq T_{amb} \leq T_{max.}$		1	300	μA
I_{ib}	Input Bias Current (see note 2) $V_{ic} = 1.5V$ $T_{min.} \leq T_{amb} \leq T_{max.}$		1	600	μA
V_{icm}	Input Common Mode Voltage Range $T_{min.} \leq T_{amb} \leq T_{max.}$	0 0		$V_{CC}^+ - 1.2$ $V_{CC}^+ - 1.5$	V
CMR	Common-mode Rejection Ratio $V_{ic} = V_{icm \text{ min.}}$		80		dB
SVR	Supply Voltage Rejection Ratio $V_{CC}^+ = 3V$ to $5V$		75		dB
V_{OH}	High Level Output Voltage $V_{id} = 1V$, $I_{OH} = -4mA$ $T_{min.} \leq T_{amb} \leq T_{max.}$	2 1.8	2.4		V
V_{OL}	Low Level Output Voltage $V_{id} = -1V$, $I_{OL} = 4mA$ $T_{min.} \leq T_{amb} \leq T_{max.}$		300	400 450	mV
I_{CC}	Supply Current (each comparator) No load - Outputs low $T_{min.} \leq T_{amb} \leq T_{max.}$		7	20 25	μA
t_{PLH}	Response Time Low to High $V_{ic} = 0V$, $f = 10kHz$, $C_L = 50pF$, Overdrive = 5mV TTL Input		1.2 0.7		μs
t_{PHL}	Response Time High to Low $V_{ic} = 0V$, $f = 10kHz$, $C_L = 50pF$, Overdrive = 5mV TTL Input		2 0.15		μs

1. The specified offset voltage is the maximum value required to drive the output up to 4.5V or down to 0.3V.

2. Maximum values including unavoidable inaccuracies of the industrial test.

ELECTRICAL CHARACTERISTICS

$V_{CC}^+ = 5V$, $V_{CC}^- = 0V$, $T_{amb} = 25^\circ C$ (unless otherwise specified)

Symbol	Parameter	Min.	Typ.	Max.	Unit
V_{io}	Input Offset Voltage $V_{ic} = 2.5V$ - note 1) $T_{min.} \leq T_{amb} \leq T_{max.}$		1.2	5 6.5	mV
I_{io}	Input Offset Voltage - note 2) $V_{ic} = 2.5V$ $T_{min.} \leq T_{amb} \leq T_{max.}$		1	300	pA
I_{ib}	Input Bias Current (see note 2) $V_{ic} = 2.5V$ $T_{min.} \leq T_{amb} \leq T_{max.}$		1	600	pA
V_{icm}	Input Common Mode Voltage Range $T_{min.} \leq T_{amb} \leq T_{max.}$	0 0		$V_{CC}^+ - 1.2$ $V_{CC}^+ - 1.5$	V
CMR	Common-mode Rejection Ratio $V_{ic} = V_{icm \text{ min.}}$		80		dB
SVR	Supply Voltage Rejection Ratio $V_{CC}^+ = +5V$ to $+10V$		92		dB
V_{OH}	High Level Output Voltage $V_{id} = 1V$, $I_{OH} = -4mA$ $T_{min.} \leq T_{amb} \leq T_{max.}$	4.5 4.3	4.7		V
V_{OL}	Low Level Output Voltage $V_{id} = -1V$, $I_{OL} = 4mA$ $T_{min.} \leq T_{amb} \leq T_{max.}$		200	300 375	mV
I_{CC}	Supply Current (each comparator) No load - Outputs low $T_{min.} \leq T_{amb} \leq T_{max.}$		9	20 25	μA
t_{PLH}	Response Time Low to High $V_{ic} = 0V$, $f = 10kHz$, $C_L = 50pF$, Overdrive = 5mV Overdrive = 10mV Overdrive = 20mV Overdrive = 40mV TTL Input		1.2 1 0.9 0.8 0.7		μs
t_{PHL}	Response Time High to Low $V_{ic} = 0V$, $f = 10kHz$, $C_L = 50pF$, Overdrive = 5mV Overdrive = 10mV Overdrive = 20mV Overdrive = 40mV TTL Input		2 1.5 0.9 0.7 0.15		μs
t_f	Fall time $f = 10kHz$, $C_L = 50pF$, Overdrive 50mV		30		ns

1. The specified offset voltage is the maximum value required to drive the output up to 4.5V or down to 0.3V.
2. Maximum values including unavoidable inaccuracies of the industrial test.

PACKAGE MECHANICAL DATA
14 PINS - PLASTIC DIP

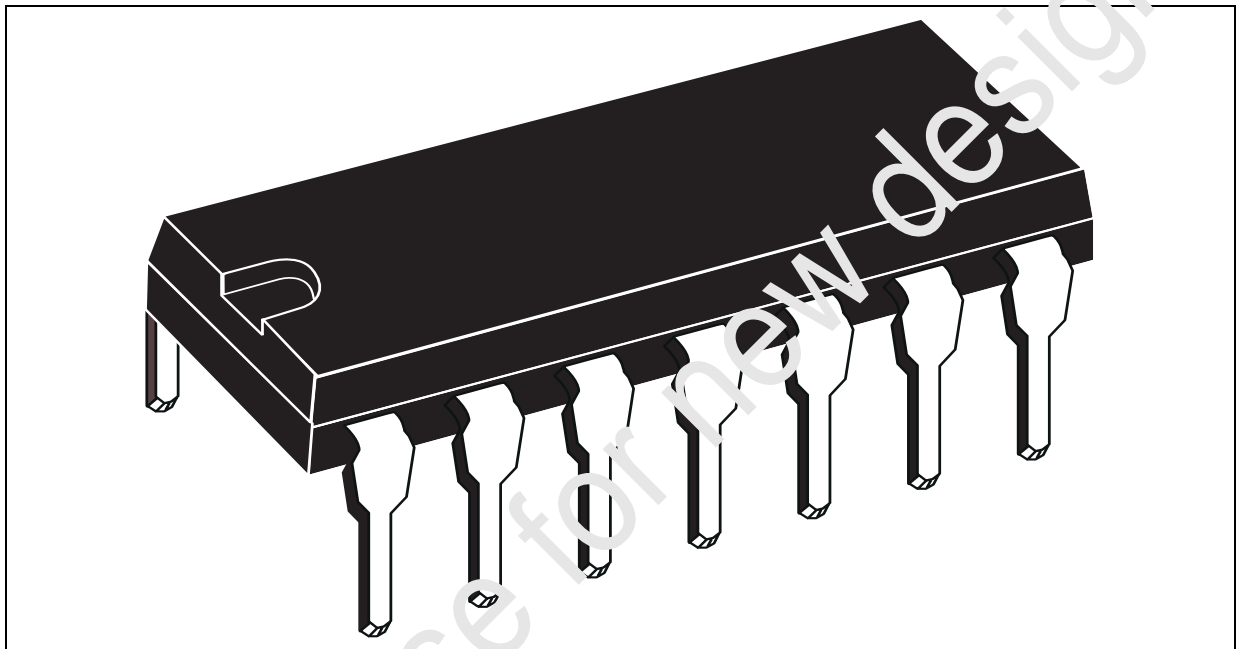

Dim.	Millimeters			Inches		
	Min.	Typ.	Max.	Min.	Typ.	Max.
a1	0.51			0.020		
B	1.39		1.65	0.055		0.065
b		0.5			0.020	
b1		0.25			0.010	
D			20			0.787
e		8.5			0.335	
e		2.54			0.100	
e3		15.24			0.600	
r			7.1			0.280
i			5.1			0.201
L		3.3			0.130	
Z	1.27		2.54	0.050		0.100

PACKAGE MECHANICAL DATA

14 PINS - PLASTIC MICROPACKAGE (SO)

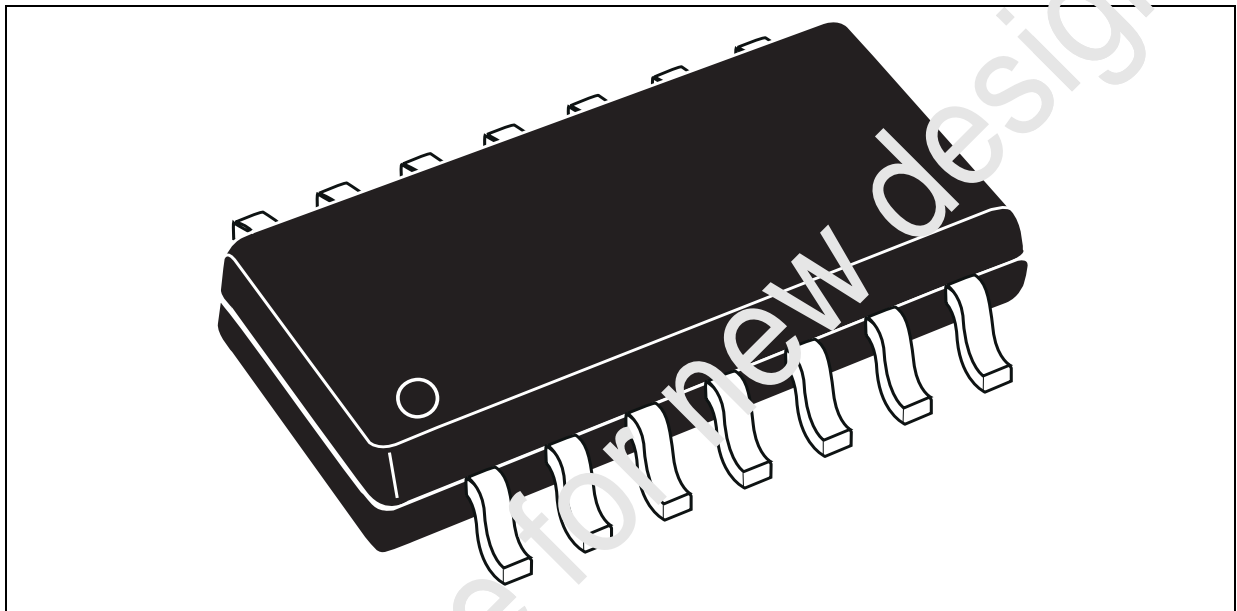

Dim.	Millimeters			Inches		
	Min.	Typ.	Max.	Min.	Typ.	Max.
A			1.75			0.069
a1	0.1		0.2	0.004		0.008
a2			1.6			0.063
b	0.35		0.46	0.014		0.018
b1	0.19		0.25	0.007		0.010
C		0.5			0.020	
c1	45° (typ.)					
D (1)	8.55		8.75	0.336		0.344
E	5.8		6.2	0.228		0.244
		1.27			0.050	
e3		7.62			0.300	
F (1)	3.8		4.0	0.150		0.157
G	4.6		5.3	0.181		0.208
L	0.5		1.27	0.020		0.050
M			0.68			0.027
S	8° (max.)					

Note : (1) D and F do not include mold flash or protrusions - Mold flash or protrusions shall not exceed 0.15mm (.066 inc) ONLY FOR DATA BOOK.

PACKAGE MECHANICAL DATA

14 PINS - THIN SHRINK SMALL OUTLINE PACKAGE (TSSOP)

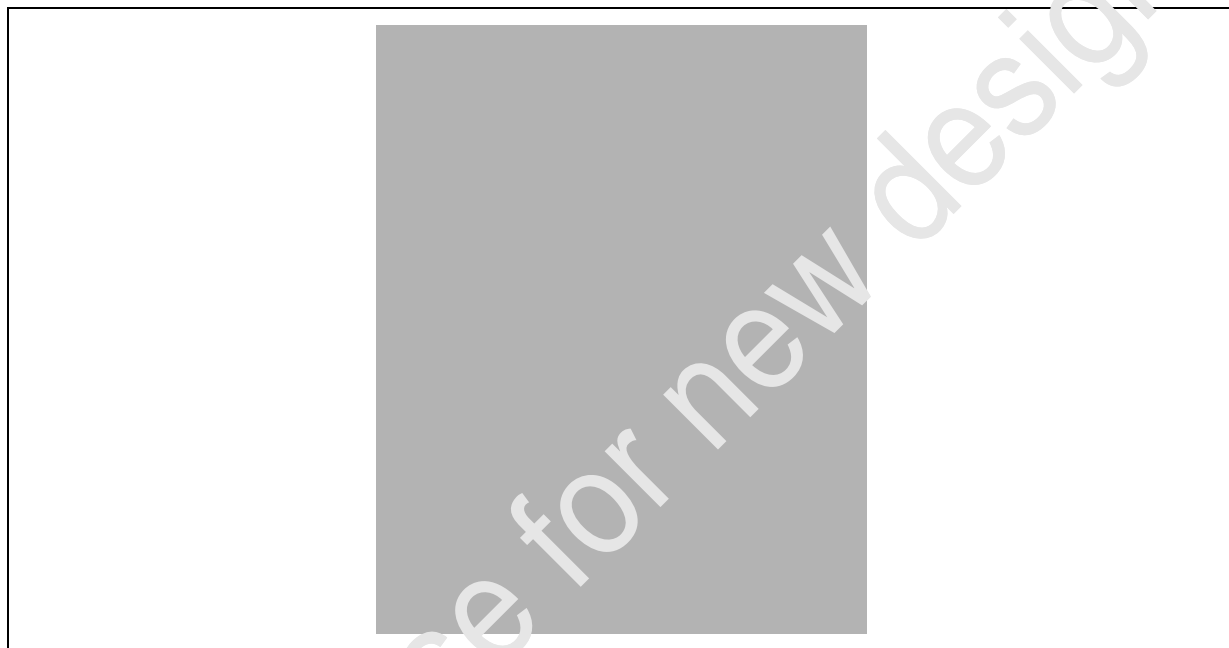

Dimensions	Millimeters			Inches		
	Min.	Typ.	Max.	Min.	Typ.	Max.
A			1.20			0.05
A1	0.05		0.15	0.01		0.006
A2	0.80	1.00	1.05	0.031	0.039	0.041
b	0.19		0.30	0.007		0.15
c	0.09		0.20	0.003		0.012
D	4.90	5.00	5.10	0.192	0.196	0.20
E		6.40			0.252	
E1	4.30	4.40	4.50	0.169	0.173	0.177
e		0.65			0.025	
k	0°		8°	0°		8°
L	0.450	0.600	0.750	0.018	0.024	0.030
L1		1.00			0.039	
aaa			0.100			0.004

Information furnished is believed to be accurate and reliable. However, STMicroelectronics assumes no responsibility for the consequences of use of such information nor for any infringement of patents or other rights of third parties which may result from its use. No license is granted by implication or otherwise under any patent or patent rights of STMicroelectronics. Specifications mentioned in this publication are subject to change without notice. This publication supersedes and replaces all information previously supplied. STMicroelectronics products are not authorized for use as critical components in life support devices or systems without express written approval of STMicroelectronics.

© The ST logo is a registered trademark of STMicroelectronics

© 2002 STMicroelectronics - Printed in Italy - All Rights Reserved
STMicroelectronics GROUP OF COMPANIES

Australia - Brazil - Canada - China - Finland - France - Germany - Hong Kong - India - Israel - Italy - Japan - Malaysia
Malta - Morocco - Singapore - Spain - Sweden - Switzerland - United Kingdom - United States

© <http://www.st.com>