

# SN54ALS29823, SN74ALS29823 9-BIT BUS-INTERFACE FLIP-FLOPS WITH 3-STATE OUTPUTS

SDAS146B - JANUARY 1986 - REVISED JANUARY 1995

- Functionally Equivalent to AMD's AM29823
- Provide Extra Data Width Necessary for Wider Address/Data Paths or Buses With Parity
- Outputs Have Undershoot-Protection Circuitry
- Power-Up High-Impedance State
- Buffered Control Inputs Reduce dc Loading Effects
- Package Options Include Plastic Small-Outline (DW) Packages and Standard Plastic (NT) and Ceramic (JT) 300-mil DIPs

SN54ALS29823 . . . JT PACKAGE  
SN74ALS29823 . . . DW OR NT PACKAGE  
(TOP VIEW)

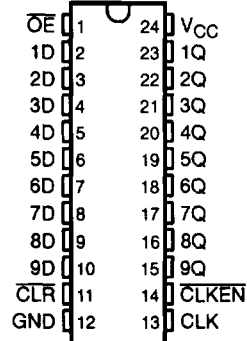

## description

These 9-bit flip-flops feature 3-state outputs designed specifically for driving highly capacitive or relatively low-impedance loads. They are particularly suitable for implementing wider buffer registers, I/O ports, bidirectional bus drivers, parity bus interfacing, and working registers.

With the clock-enable ( $\overline{\text{CLKEN}}$ ) input low, the nine D-type edge-triggered flip-flops enter data on the low-to-high transitions of the clock (CLK) input. Taking  $\overline{\text{CLKEN}}$  high disables the clock buffer, latching the outputs. The 'ALS29823 have noninverting data (D) inputs. Taking the clear ( $\overline{\text{CLR}}$ ) input low causes the nine Q outputs to go low independently of the clock.

A buffered output-enable ( $\overline{\text{OE}}$ ) input places the nine outputs in either a normal logic state (high or low logic levels) or a high-impedance state. The outputs also are in the high-impedance state during power-up and power-down conditions. The outputs remain in the high-impedance state while the device is powered down. In the high-impedance state, the outputs neither load nor drive the bus lines significantly. The high-impedance state and increased drive provide the capability to drive bus lines without interface or pullup components.

$\overline{\text{OE}}$  does not affect the internal operation of the flip-flops. Old data can be retained or new data can be entered while the outputs are in the high-impedance state.

The SN54ALS29823 is characterized for operation over the full military temperature range of  $-55^{\circ}\text{C}$  to  $125^{\circ}\text{C}$ . The SN74ALS29823 is characterized for operation from  $0^{\circ}\text{C}$  to  $70^{\circ}\text{C}$ .

**FUNCTION TABLE**  
(each flip-flop)

INPUTS					OUTPUT Q
$\overline{\text{OE}}$	$\overline{\text{CLR}}$	$\overline{\text{CLKEN}}$	CLK	D	
L	L	X	X	X	L
L	H	L	$\uparrow$	H	H
L	H	L	$\uparrow$	L	L
L	H	H	X	X	$Q_0$
H	X	X	X	X	Z

PRODUCTION DATA Information is current as of publication date. Products conform to specifications per the terms of Texas Instruments standard warranty. Production processing does not necessarily include testing of all parameters.



POST OFFICE BOX 655303 • DALLAS, TEXAS 75265

Copyright © 1995, Texas Instruments Incorporated

**SN54ALS29823, SN74ALS29823**  
**9-BIT BUS-INTERFACE FLIP-FLOPS**  
**WITH 3-STATE OUTPUTS**

SDAS146B - JANUARY 1986 - REVISED JANUARY 1995

**logic symbol†**

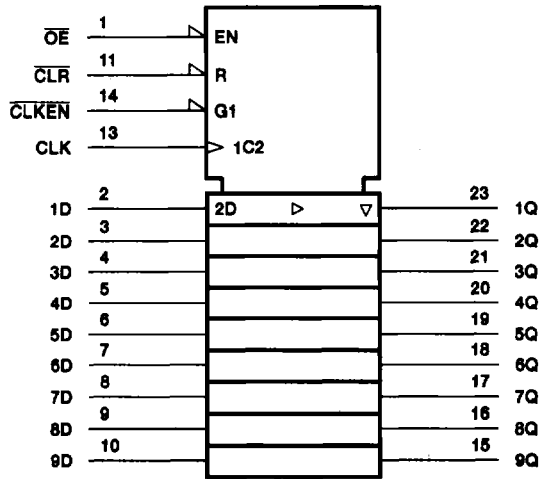

† This symbol is in accordance with ANSI/IEEE Std 91-1984 and IEC Publication 617-12.

**logic diagram (positive logic)**

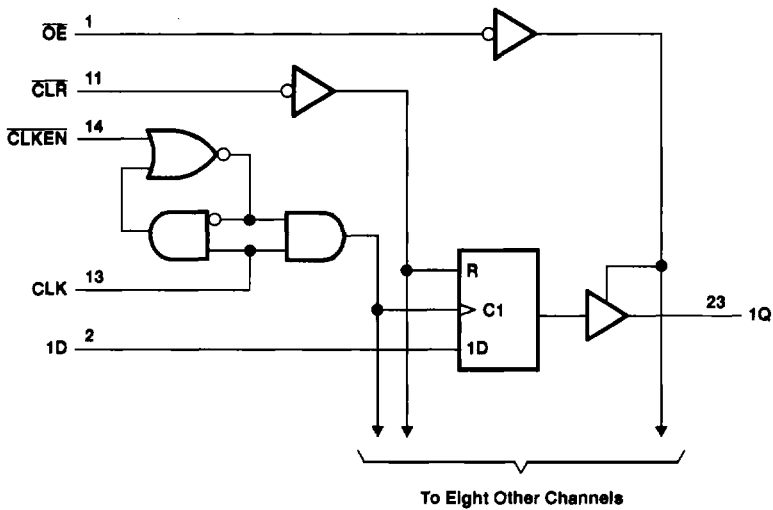

# SN54ALS29823, SN74ALS29823 9-BIT BUS-INTERFACE FLIP-FLOPS WITH 3-STATE OUTPUTS

SDAS146B - JANUARY 1986 - REVISED JANUARY 1995

## absolute maximum ratings over operating free-air temperature range (unless otherwise noted)†

Supply voltage, $V_{CC}$ .....	7 V
Input voltage, $V_I$ .....	5.5 V
Voltage applied to a disabled high-impedance output .....	5.5 V
Operating free-air temperature range, $T_A$ : SN54ALS29823 .....	-55°C to 125°C
Storage temperature range .....	-65°C to 150°C

† Stresses beyond those listed under "absolute maximum ratings" may cause permanent damage to the device. These are stress ratings only, and functional operation of the device at these or any other conditions beyond those indicated under "recommended operating conditions" is not implied. Exposure to absolute-maximum-rated conditions for extended periods may affect device reliability.

## recommended operating conditions

		SN54ALS29823			UNIT
		MIN	NOM	MAX	
$V_{CC}$	Supply voltage	4.5	5	5.5	V
$V_{IH}$	High-level input voltage	2			V
$V_{IL}$	Low-level input voltage			0.8	V
$I_{OH}$	High-level output current			-18	mA
$I_{OL}$	Low-level output current			32	mA
$t_w$	Pulse duration	CLR low	7		ns
		CLK high or low	8		
$t_{su}$	Setup time before CLK↑	CLR inactive	7		ns
		Data	4		
		CLKEN high or low	8		
$t_h$	Hold time after CLK↑	CLKEN	2		ns
		Data	4		
$T_A$	Operating free-air temperature	-55	25	125	°C

## electrical characteristics over recommended operating free-air temperature range (unless otherwise noted)

PARAMETER	TEST CONDITIONS		SN54ALS29823			UNIT	
			MIN	TYP‡	MAX		
$V_{IK}$	$V_{CC} = 4.5 V$ ,	$I_I = -18 mA$			-1.2	V	
$V_{OH}$	$V_{CC} = 4.5 V$	$I_{OH} = -12 mA$	2.4	3.3		V	
		$I_{OH} = -18 mA$	2				
$V_{OL}$	$V_{CC} = 4.5 V$ ,	$I_{OL} = 32 mA$		0.25	0.5	V	
$I_{OZH}$	$V_{CC} = 5.5 V$ ,	$V_O = 2.4 V$			50	μA	
$I_{OZL}$	$V_{CC} = 5.5 V$ ,	$V_O = 0.4 V$			-50	μA	
$I_I$	$V_{CC} = 5.5 V$ ,	$V_I = 5.5 V$			0.1	mA	
$I_{IH}$	$V_{CC} = 5.5 V$ ,	$V_I = 2.7 V$			20	μA	
$I_{IL}$	$V_{CC} = 5.5 V$ ,	$V_I = 0.4 V$			-0.5	mA	
$I_{OS}§$	$V_{CC} = 5.5 V$ ,	$V_O = 0$			-75	-250	mA
$I_{CC}$	$V_{CC} = 5.5 V$	Outputs high			90	mA	
		Outputs low			105		
		Outputs open			115		

‡ All typical values are at  $V_{CC} = 5 V$ ,  $T_A = 25°C$ .

§ Not more than one output should be shorted at a time, and the duration of the short circuit should not exceed one second.



POST OFFICE BOX 855303 • DALLAS, TEXAS 75285

**SN54ALS29823, SN74ALS29823**  
**9-BIT BUS-INTERFACE FLIP-FLOPS**  
**WITH 3-STATE OUTPUTS**

SDAS148B - JANUARY 1986 - REVISED JANUARY 1995

**switching characteristics (see Figure 1)**

PARAMETER	FROM (INPUT)	TO (OUTPUT)	TEST CONDITIONS	VCC = MIN to MAX†, TA = MIN to MAX†		UNIT
				SN54ALS29823		
				MIN	MAX	
tPLH	CLK	Any Q	CL = 50 pF	2	11.5	ns
tPHL				2	11.5	
tPLH	CLK	Any Q	CL = 300 pF	2	21	ns
tPHL				2	21	
tPHL	CLR	Any Q	CL = 50 pF	1	17.5	ns
tPZH	OE	Any Q	CL = 50 pF	1	17	ns
tPZL				1	17	
tPZH	OE	Any Q	CL = 300 pF	1	25	ns
tPZL				1	29.5	
tPHZ	OE	Any Q	CL = 50 pF	1	16	ns
tPLZ				1	14	
tPHZ	OE	Any Q	CL = 5 pF	1	12	ns
tPLZ				1	11	

† For conditions shown as MIN or MAX, use the appropriate value specified under recommended operating conditions.

**absolute maximum ratings over operating free-air temperature range (unless otherwise noted)‡**

Supply voltage, VCC	7 V
Input voltage, VI	5.5 V
Voltage applied to a disabled 3-state output	5.5 V
Operating free-air temperature range, TA: SN74ALS29823	0°C to 70°C
Storage temperature range	-65°C to 150°C

‡ Stresses beyond those listed under "absolute maximum ratings" may cause permanent damage to the device. These are stress ratings only, and functional operation of the device at these or any other conditions beyond those indicated under "recommended operating conditions" is not implied. Exposure to absolute-maximum-rated conditions for extended periods may affect device reliability.

**recommended operating conditions**

		SN74ALS29823			UNIT
		MIN	NOM	MAX	
VCC	Supply voltage	4.75	5	5.25	V
VIH	High-level input voltage	2			V
VIL	Low-level input voltage			0.8	V
IOH	High-level output current			-24	mA
IOL	Low-level output current			48	mA
tw	Pulse duration	CLR low	5		ns
		CLK high or low	5		
tsu	Setup time before CLK†	CLR inactive	5		ns
		Data	2		
		CLKEN high or low	6		
th	Hold time after CLK†	CLKEN	0		ns
		Data	2		
TA	Operating free-air temperature	0	25	70	°C



POST OFFICE BOX 655303 • DALLAS, TEXAS 75265

# SN54ALS29823, SN74ALS29823 9-BIT BUS-INTERFACE FLIP-FLOPS WITH 3-STATE OUTPUTS

SDAS146B - JANUARY 1986 - REVISED JANUARY 1985

electrical characteristics over recommended operating free-air temperature range (unless otherwise noted)

PARAMETER	TEST CONDITIONS		SN74ALS29823		UNIT
			MIN	TYP†	
$V_{IK}$	$V_{CC} = 4.75 \text{ V}$ ,	$I_I = -18 \text{ mA}$	-1.2		V
$V_{OH}$	$V_{CC} = 4.75 \text{ V}$	$I_{OH} = -15 \text{ mA}$	2.4	3.3	V
		$I_{OH} = -24 \text{ mA}$	2	3.1	
$V_{OL}$	$V_{CC} = 4.75 \text{ V}$ ,	$I_{OL} = 48 \text{ mA}$	0.35	0.5	V
$I_{OZH}$	$V_{CC} = 5.25 \text{ V}$ ,	$V_O = 2.4 \text{ V}$	20		$\mu\text{A}$
$I_{OZL}$	$V_{CC} = 5.25 \text{ V}$ ,	$V_O = 0.4 \text{ V}$	-20		$\mu\text{A}$
$I_I$	$V_{CC} = 5.25 \text{ V}$ ,	$V_I = 5.5 \text{ V}$	0.1		mA
$I_{IH}$	$V_{CC} = 5.25 \text{ V}$ ,	$V_I = 2.7 \text{ V}$	20		$\mu\text{A}$
$I_{IL}$	$V_{CC} = 5.25 \text{ V}$ ,	$V_I = 0.4 \text{ V}$	-0.2		mA
$I_{OS}^\ddagger$	$V_{CC} = 5.25 \text{ V}$ ,	$V_O = 0$	-75	-250	mA
$I_{CC}$	$V_{CC} = 5.25 \text{ V}$ ,	Outputs open	80	115	mA

† All typical values are at  $V_{CC} = 5 \text{ V}$ ,  $T_A = 25^\circ\text{C}$ .

‡ Not more than one output should be shorted at a time, and the duration of the short circuit should not exceed one second.

### switching characteristics (see Figure 1)

PARAMETER	FROM (INPUT)	TO (OUTPUT)	TEST CONDITIONS	$V_{CC} = \text{MIN to MAX}^\S$ , $T_A = \text{MIN to MAX}^\S$		UNIT
				SN74ALS29823		
				MIN	MAX	
$t_{PLH}$	CLK	Any Q	$C_L = 50 \text{ pF}$	2	10	ns
$t_{PHL}$				2	10	
$t_{PLH}$	CLK	Any Q	$C_L = 300 \text{ pF}$	16		ns
$t_{PHL}$				16		
$t_{PHL}$	$\overline{\text{CLR}}$	Any Q	$C_L = 50 \text{ pF}$	12		ns
$t_{PZH}$	$\overline{\text{OE}}$	Any Q	$C_L = 50 \text{ pF}$	14		ns
$t_{PZL}$				14		
$t_{PZH}$	$\overline{\text{OE}}$	Any Q	$C_L = 300 \text{ pF}$	20		ns
$t_{PZL}$				23		
$t_{PHZ}$	$\overline{\text{OE}}$	Any Q	$C_L = 50 \text{ pF}$	14		ns
$t_{PLZ}$				12		
$t_{PHZ}$	$\overline{\text{OE}}$	Any Q	$C_L = 5 \text{ pF}$	9		ns
$t_{PLZ}$				9		

§ For conditions shown as MIN or MAX, use the appropriate value specified under recommended operating conditions.



POST OFFICE BOX 665303 • DALLAS, TEXAS 75265

**SN54ALS29823, SN74ALS29823**  
**9-BIT BUS-INTERFACE FLIP-FLOPS**  
**WITH 3-STATE OUTPUTS**

SDAS146B - JANUARY 1986 - REVISED JANUARY 1985

**PARAMETER MEASUREMENT INFORMATION**

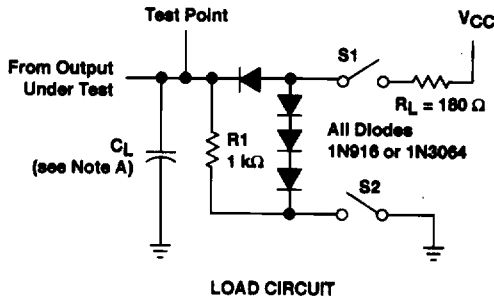

**SWITCH POSITION TABLE**

TEST	S1	S2
t <sub>PLH</sub>	Closed	Closed
t <sub>PHL</sub>	Closed	Closed
t <sub>PZH</sub>	Open	Closed
t <sub>PZL</sub>	Closed	Open
t <sub>PHZ</sub>	Closed	Closed
t <sub>PLZ</sub>	Closed	Closed

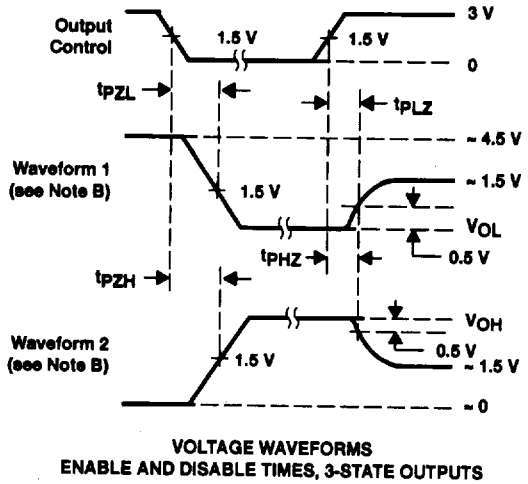
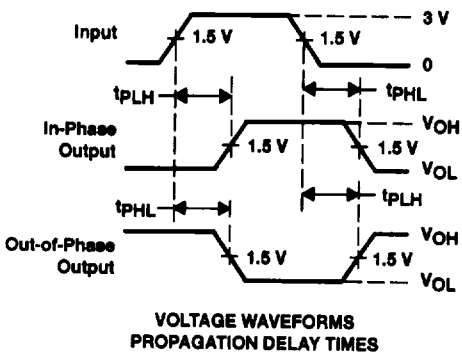
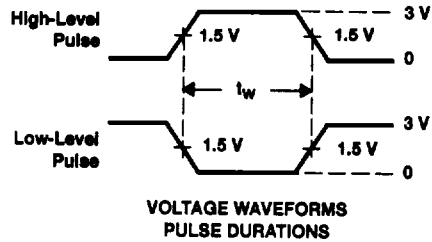
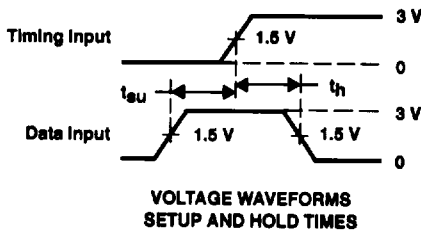

- NOTES: A.  $C_L$  includes probe and jig capacitance.  
 B. Waveform 1 is for an output with internal conditions such that the output is low except when disabled by the output control. Waveform 2 is for an output with internal conditions such that the output is high except when disabled by the output control.  
 C. All Input pulses are supplied by generators having the following characteristics: PRR  $\leq$  10 MHz,  $Z_O = 50 \Omega$ ,  $t_r \leq 2.5$  ns,  $t_f \leq 2.5$  ns.

**Figure 1. Load Circuit and Voltage Waveforms**